

ABBREVIATIONS AND SYMBOLS

Table with 4 columns of abbreviations and symbols, including terms like ARCHITECT/ENGINEER, FOUNDATION, POWDER ACTUATED FASTENER, etc.

DRAWING LEGEND

General Annotations, Concrete Construction, Steel Construction, Masonry Construction, Materials. Includes symbols for concrete spread footing, steel column, masonry wall, etc.

DESIGN CRITERIA

- DC-1 BUILDING CODE: A. INTERNATIONAL BUILDING CODE (IBC) 2021 AS AMENDED BY... DC-2 VERTICAL LOADS... DC-3 LATERAL LOADS... DC-4 FOUNDATION DESIGN CRITERIA... DC-5 ANTITERRORISM (AT) CRITERIA...



US Army Corps of Engineers

Table with columns: DATE, DESCRIPTION, MARK

Table with columns: DESIGNED BY, DRAWN BY, CHECKED BY, SUBMITTED BY, SIZE, ANS I D

US ARMY CORPS OF ENGINEERS LOS ANGELES DISTRICT... KORTE CONSTRUCTION 5700 OAKLAND AVE SUITE 275 ST. LOUIS, MO 63110

CREECH AIR FORCE BASE, CLARK COUNTY, NV... DISASTER RESILIENCY PROGRAM (DRP) - PHASE 2... STRUCTURAL DESIGN CRITERIA, LEGEND, AND ABBREVIATIONS

SHEET ID S-001

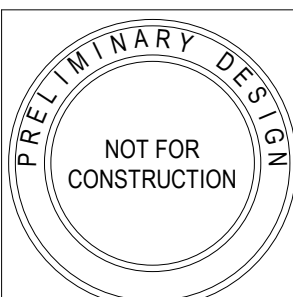

GENERAL

- G-1 METHODS, PROCEDURES AND SEQUENCES OF CONSTRUCTION ARE THE RESPONSIBILITY OF THE CONTRACTOR. THE CONTRACTOR IS RESPONSIBLE FOR IMPLEMENTING THE NECESSARY PRECAUTIONS TO MAINTAIN THE INTEGRITY OF THE STRUCTURE AT EACH STAGE OF CONSTRUCTION.
G-2 STRUCTURAL ENGINEER WILL NOT BE RESPONSIBLE FOR ACTIVITIES UNDER THE CONTROL OF THE CONTRACTOR SUCH AS CONSTRUCTION SITE SAFETY, MEANS, METHODS AND SEQUENCES OF CONSTRUCTION. STRUCTURAL ENGINEER WILL NOT BE RESPONSIBLE FOR FABRICATION, ERECTION AND CONSTRUCTION REQUIREMENTS AS PRESCRIBED BY OSHA OR OTHER REGULATORY AGENCIES REGARDLESS OF INDICATION IN THESE DOCUMENTS. THE CONTRACTOR IS SOLELY RESPONSIBLE FOR ALL SAFETY REGULATIONS, PROGRAMS AND PRECAUTIONS RELATED TO ALL WORK ON THE PROJECT.
G-3 WHERE SUPPORTED SLABS OR ROOFS ARE TO BE USED FOR STAGING OR TEMPORARY CONSTRUCTION LOADS, THE CONTRACTOR MUST VERIFY THAT APPLIED LOADS DO NOT EXCEED THE DESIGN LOADS FOR THE SUPPORTING FLOORS OR ROOFS. DURING AND AFTER CONSTRUCTION, CONTRACTOR AND/OR CONTRACTING OFFICER MUST KEEP LOADS ON THE STRUCTURE WITHIN THE LIMITS OF THE DESIGN LOADS AS NOTED IN THESE DRAWINGS.
G-4 THE STRUCTURAL SYSTEMS SHOWN IN THESE DRAWINGS MUST NOT BE CONSIDERED STABLE UNTIL ALL STRUCTURAL ELEMENTS ARE IN PLACE AND COMPLETED. TEMPORARY BRACING, SHEETING, SHORING, ETC. REQUIRED TO ENSURE THE STRUCTURAL INTEGRITY/STABILITY OF THE EXISTING BUILDINGS, SIDEWALKS, UTILITIES, ETC, DURING CONSTRUCTION IS THE RESPONSIBILITY OF THE CONTRACTOR AND MUST BE DESIGNED BY A REGISTERED PROFESSIONAL ENGINEER EMPLOYED BY THE CONTRACTOR.
G-5 WHEN NOT SPECIFICALLY INDICATED ON THE STRUCTURAL DRAWINGS, THE CONTRACTOR IS RESPONSIBLE FOR DETERMINING SLEEVE AND BLOCK-OUT REQUIREMENTS FOR PENETRATIONS PRIOR TO FABRICATION OR ERECTION OF THE STRUCTURE. PENETRATIONS OF STRUCTURAL MEMBERS ARE SUBJECT TO APPROVAL BY THE EOR. THE CONTRACTOR IS ALSO RESPONSIBLE FOR DETERMINING ANCHORAGE AND HANGER REQUIREMENTS REQUIRED FOR SUPPORTING EQUIPMENT, FINISHES, UTILITIES ET CETERA NOT INDICATED ON THE STRUCTURAL DRAWINGS.
G-6 CONTRACTOR MUST COORDINATE WITH ALL TRADES THE LOCATIONS AND DIMENSIONS OF ALL OPENINGS THROUGH FLOORS, ROOFS AND WALLS REGARDLESS OF IF THEY ARE SHOWN ON THE STRUCTURAL DRAWINGS.
G-7 THE CONTRACTOR IS RESPONSIBLE FOR COORDINATING DIMENSIONS AND INSTALLATION REQUIREMENTS OF EQUIPMENT WITH THE SUPPORTING STRUCTURE.
G-8 THE STRUCTURAL DRAWINGS ARE SUPPLEMENTARY TO THE ARCHITECTURAL AND OTHER DISCIPLINE DRAWINGS. DO NOT ATTEMPT TO BID NOR CONSTRUCT ANY PORTION OF THIS PROJECT WITHOUT CONSULTING OTHER DISCIPLINES' DRAWINGS WITHIN THIS PROJECT. ALL CONFLICTS OR OMISSIONS, INCLUDING DIMENSIONS, BETWEEN THE VARIOUS ELEMENTS OF THE STRUCTURAL DRAWINGS AND/OR SPECIFICATIONS MUST BE BROUGHT TO THE ATTENTION OF THE ARCHITECT AND ENGINEER BEFORE PROCEEDING WITH ANY WORK INVOLVED. IN CASE THERE IS A CONFLICT BETWEEN DRAWINGS, SUBMIT A REQUEST FOR INFORMATION, AND PROCEED AS DIRECTED BY THE ENGINEER. ANY WORK DONE BY THE CONTRACTOR AFTER DISCOVERY OF SUCH DISCREPANCY WITHOUT OFFICIAL DIRECTION WILL BE DONE AT THE CONTRACTOR'S RISK.
G-9 FIREPROOFING, IF REQUIRED, OF STRUCTURAL ELEMENTS IS NOT SHOWN ON THE STRUCTURAL DRAWINGS. REFER TO THE SPECIFICATIONS, FIRE PROTECTION DRAWINGS AND/OR ARCHITECTURAL DRAWINGS.
G-10 IN CASE OF CONFLICT BETWEEN THE GENERAL NOTES, SPECIFICATIONS, DRAWINGS, OR WITHIN THESE DOCUMENTS, THE MOST STRINGENT REQUIREMENTS AS DETERMINED BY THE ENGINEER WILL GOVERN.
G-11 WORK NOT INDICATED ON A PART OF THE DRAWINGS, BUT REASONABLY IMPLIED TO BE SIMILAR TO THAT SHOWN AT CORRESPONDING LOCATIONS, IS TO BE REPEATED.
G-12 TYPICAL DETAILS ARE GENERALLY NOT REFERENCED ON THE DRAWINGS AND WILL APPLY IN AREAS WHERE CONDITIONS ARE SIMILAR AS DESCRIBED IN THE DETAILS. THE CONTRACTOR MUST IDENTIFY, COORDINATE AND APPLY THESE DETAILS AS NEEDED. TYPICAL DETAILS MAY BE REFERENCED ON PLANS OR DETAILS TO CLARIFY OR IDENTIFY A PARTICULAR CONDITION. THE PRESENCE OF SUCH A REFERENCE DOES NOT ALTER THE OBLIGATION OF THE CONTRACTOR TO APPLY THE DETAIL(S) AS NEEDED EVEN IF THEY ARE NOT REFERENCED.
G-13 THE STRUCTURAL DOCUMENTS HAVE BEEN DRAWN TO SCALE AS INDICATED ON THESE DRAWINGS. THIS IS TO CONFIRM GENERAL GEOMETRIC TOLERANCES TO THE GREATEST EXTENT POSSIBLE. HOWEVER, SOME COMPONENTS MAY NOT BE DRAWN TO SCALE TO REFLECT DESIGN INTENT. IF DIMENSIONAL INFORMATION IS NOT INDICATED AND/OR PROVIDED, THE ENGINEER MUST BE NOTIFIED IN WRITING. DO NOT SCALE DRAWINGS.

- B. SHOP DRAWINGS MUST BE CHECKED AND STAMPED BY THE CONTRACTOR PRIOR TO SUBMISSION. THE CONTRACTOR'S STAMP OF APPROVAL WILL CONSTITUTE CERTIFICATION THAT HE HAS VERIFIED FIELD MEASUREMENTS, CONSTRUCTION CRITERIA, MATERIALS AND SIMILAR DATA AND HAS CHECKED EACH DRAWING FOR COMPLETENESS, COORDINATION, AND COMPLIANCE WITH THE CONTRACT DOCUMENTS. SHOP DRAWINGS SUBMITTED WITHOUT THE CONTRACTOR'S STAMP AND REVIEW WILL BE RETURNED WITHOUT REVIEW BY THE ENGINEER.
C. REPRODUCTION OF ANY PORTION OF THE STRUCTURAL CONTRACT DRAWINGS FOR SUBMITTAL AS SHOP DRAWINGS IS PROHIBITED. SUBMITTALS PROVIDED THAT INCLUDE REPRODUCTION OF THE CONTRACT DRAWINGS WILL BE RETURNED WITHOUT REVIEW BY THE ENGINEER.
D. CHANGES TO SHOP DRAWINGS THAT ARE RE-SUBMITTED MUST BE CLOUDED OR SOMEHOW INDICATE THAT A CHANGE HAS BEEN MADE TO PREVIOUSLY ISSUED AND REVIEWED DRAWINGS. REVISED SHOP DRAWINGS PROVIDED WITHOUT CLOUDS OR CHANGES INDICATED WILL BE RETURNED WITHOUT REVIEW BY THE ENGINEER.
E. THE CONTRACTOR IS TO PROVIDE THE ENGINEER AND CONTRACTING OFFICER WITH WRITTEN NOTICE OF DEVIATIONS OF ANY TYPE FROM THE REQUIREMENTS OF THE CONSTRUCTION DOCUMENTS. THE NOTICE MUST BE RECEIVED PRIOR TO SHOP DRAWING SUBMITTAL. THE CONTRACTOR REMAINS LIABLE FOR ANY DEVIATION UNLESS REVIEWED BY THE ENGINEER AND CONTRACTING OFFICER AND ACKNOWLEDGED IN WRITING, PRIOR TO THE RECEIPT OF THE SHOP DRAWINGS.
F. CONTRACTOR IS NOT RELIEVED OF ANY REQUIREMENT OF THE CONTRACT DOCUMENTS BY VIRTUE OF ENGINEER OR CONTRACTING OFFICER REVIEW OF SUBMITTALS.
G. REVIEW OF SUBMITTALS BY THE ENGINEER IS FOR GENERAL COMPLIANCE WITH THE CONTRACT DOCUMENTS ONLY AND IS NOT INTENDED AS APPROVAL.

CA-4 UNLESS NOTED OTHERWISE, ALLOW 10 BUSINESS DAYS FOR THE ENGINEER'S REVIEW.
CA-5 A QUALIFIED TESTING AGENCY MUST PERFORM TESTS AND SPECIAL INSPECTIONS. UPON COMPLETION OF WORK, THE TESTING AGENCY MUST FURNISH A CERTIFICATE OF COMPLIANCE, SIGNED BY THE PROFESSIONAL ENGINEER RESPONSIBLE FOR MANGEMENT OF THE AGENCY. THE PROFESSIONAL ENGINEER MUST BE REGISTERED IN THE UNITED STATES.

FOUNDATIONS

- F-1 FOUNDATIONS HAVE BEEN DESIGNED AND MUST BE CONSTRUCTED IN ACCORDANCE WITH THE GEOTECHNICAL REPORT FOR THIS PROJECT AS LISTED IN THE DESIGN CRITERIA WHICH IS CONSIDERED AS THE BASIS OF FOUNDATION DESIGN. CONTRACTOR IS RESPONSIBLE FOR REVIEWING AND UNDERSTANDING REQUIREMENTS SET FORTH WITHIN THE REPORT AS THEY APPLY TO THIS FOUNDATION DESIGN. THE STRUCTURAL ENGINEER IS NOT LIABLE OR RESPONSIBLE FOR THE ACCURACY OF RECOMMENDATIONS PRESENTED WITHIN THE GEOTECHNICAL REPORT.
F-2 FOUNDATIONS MUST BE PLACED ON A MINIMUM OF 30" LAYER OF COMPACTED SELECT FILL AND A 6" LAYER OF SCARIFIED RE-COMPACTED SUBGRADE, CONFORMING TO RECOMMENDATIONS PROVIDED IN THE GEOTECHNICAL REPORT (MAXIMUM FILL LIFT = 8").
F-3 THE CONTRACTOR IS TO RETAIN THE SERVICES OF A PROFESSIONAL GEOTECHNICAL ENGINEER, SUBJECT TO THE APPROVAL OF THE CONTRACTING OFFICER, TO VERIFY THAT THE MATERIAL ON WHICH FOUNDATIONS BEAR HAS AT LEAST THE CAPACITY AS NOTED IN THE DESIGN CRITERIA. PRIOR TO PLACING CONCRETE, AND AFTER COMPACTION OF SUBGRADE, ALL FOUNDATION EXCAVATIONS SHALL BE INSPECTED AND TESTED WHICH MUST INCLUDE IN PLACE DENSITY TESTING. IF THE SUBGRADE HAS LESS THAN THE STATED ALLOWABLE BEARING CAPACITY, THE WEAK SUBGRADE SHALL BE REMOVED, RECOMPACTED, AND RETESTED UNTIL IT IS SATISFACTORY AT NO ADDITIONAL COST TO THE OWNER. CONCRETE PLACEMENT SHALL NOT PROCEED UNTIL THE SUBGRADE MEETS THE MINIMUM DENSITY REQUIREMENTS OF THE SPECIFICATIONS AND THE GEOTECHNICAL REPORT, WHICHEVER IS MORE STRINGENT.
F-4 EXTERIOR FOUNDATONS ARE TO BEAR BELOW THE MINIMUM BEARING DEPTH FROM FINISHED GRADE GIVEN IN DESIGN CRITERIA GENERAL NOTE DC-4. INTERIOR FOUNDATIONS TO BEAR THE MINIMUM BEARING DEPTH OR AS INDICATED. FINAL BEARING ELEVATIONS MAY VARY TO SUIT SUBSURFACE SOIL CONDITIONS OR BELOW GRADE UTILITIES. NOTIFY THE ENGINEER AND CONTRACTING OFFICER OF ANY CHANGES. PROVIDE FOUNDATION STEPS AS NECESSARY.
F-5 NO BACKFILLING AGAINST WALLS IS ALLOWED UNTIL THE SLABS AT THE TOP AND BOTTOM HAVE BEEN PLACED OR ADEQUATE SHORING HAS BEEN PROVIDED. WALLS AND GRADE BEAMS HAVING BACKFILL AGAINST BOTH SIDES ARE TO HAVE BACKFILL PLACED ON BOTH SIDES UNIFORMLY SO AS NOT TO EXCEED AN 8" DIFFERENTIAL.
F-6 FOUNDATION DRAINAGE, INSULATION AND/OR WATERPROOFING IS NOT SHOWN OR SPECIFIED WITHIN THE STRUCTURAL PORTION OF THE CONSTRUCTION DOCUMENTS. REFERENCE OTHER PORTIONS OF THE CONSTRUCTION DOCUMENTS FOR DRAINAGE, INSULATION AND/OR WATERPROOFING, OR ITEMS ASSOCIATED WITH OTHER DISCIPLINES.

REINFORCED CONCRETE

- C-1 REINFORCED CONCRETE WORK MUST BE IN ACCORDANCE WITH THE AMERICAN CONCRETE INSTITUTE (ACI) "BUILDING CODE REQUIREMENTS FOR STRUCTURAL CONCRETE - ACI 318" AND THE "SPECIFICATIONS FOR STRUCTURAL CONCRETE FOR BUILDINGS- ACI 301."
C-2 MAXIMUM MIX DESIGN W/C RATIO MUST NOT BE EXCEEDED. APPROVED ADMIXTURES SUCH AS PLASTICIZERS OR SUPERPLASTICIZERS MAY BE USED ON SITE TO INCREASE SLUMP AND FLOWABILITY AS REQUIRED FOR PLACEMENT. REFER TO ACI 311.5 FOR DOCUMENTATION REQUIREMENTS AND IBC CHAPTER 1703 FOR INSPECTION REQUIREMENTS.
C-3 CAST-IN-PLACE CONCRETE MUST HAVE A MINIMUM 28 DAY COMPRESSIVE STRENGTH (fc) AS INDICATED ON THE CONCRETE MIX DESIGN TABLE.
C-4 THE STRUCTURE SUPPORTING ELEVATED FLOORS IS DESIGNED TO HAVE AN INITIAL (PRE-COMPOSITE) DEFLECTION OF NOT MORE THAN 1/4" DUE TO THE WEIGHT OF THE CONCRETE SLAB. THE CONTRACTOR MUST TAKE THIS DEFLECTION INTO ACCOUNT WHEN DETERMINING THE AMOUNT OF CONCRETE NECESSARY TO OBTAIN A LEVEL FLOOR AND MONITOR DEFLECTION DURING CONCRETE PLACEMENT.
C-5 REINFORCEMENT AND EMBEDDED ITEMS:
A. PROVIDE STANDARD HOOKS ON BARS TERMINATING AT A CONCRETE FACE UNLESS NOTED SUCH AS AT EDGES OF OPENINGS, SLAB EDGES, EXPANSION JOINTS, ENDS OF BEAMS AND ENDS OF WALLS.

- B. SEE CONCRETE REINFORCEMENT DEVELOPMENT LENGTH AND SPLICE TABLE FOR ALL REQUIRED DEVELOPMENT AND SPLICE LENGTHS.
C. PROVIDE ADEQUATE CONCRETE COVER IN ACCORDANCE WITH THE REQUIREMENTS AS SET FORTH BY ACI 318 AND AS PROVIDED WITHIN THE CONCRETE COVER TABLE IN THE SPECIFICATIONS.
D. HOOKED BARS TO HAVE STANDARD ACI HOOKS UNLESS NOTED OTHERWISE. UNLESS NOTED OTHERWISE, HOOKS CAN BE ORIENTED AS REQUIRED.
E. CONTINUOUS REINFORCING BARS MUST BE TURNED AND LAPPED AT CORNERS AND INTERSECTIONS OF WALLS AND FOOTINGS.
F. WELDING OF REINFORCEMENT IS PROHIBITED, UNLESS NOTED OTHERWISE AND MUST CONFORM TO ASTM A706.
G. PROVIDE EMBEDS (INCLUDING ANCHORS), AS REQUIRED, FOR ALL SUPPORTING NON-STRUCTURAL ELEMENTS INCLUDING BUT NOT LIMITED TO HAND RAILS, CANOPIES, WINDOW WASHING DAVITS, MISCELLANEOUS STEEL, ETC. REFER TO ARCHITECTURAL AND MEP DRAWINGS FOR ADDITIONAL INFORMATION.
C-6 CONCRETE SLABS MUST BE CURED BY METHOD COMPATIBLE WITH SPECIFIED FLOOR FINISH. WHERE ACCEPTABLE USE A LIQUID MEMBRANE-CURING COMPOUND AT THE MANUFACTURERS RECOMMENDED COVERAGE.
C-7 CONCRETE SLAB CONTROL JOINT PLACEMENT AND LAYOUT PER GC AND SUBMITTED AS SHOP DRAWING FOR REVIEW.
C-8 SLEEVES, INSERTS, MECHANICAL OPENINGS, CONDUITS, PIPES, RECESSES, DEPRESSIONS, CURBS AND OTHER EMBEDDED ITEMS MUST BE PROVIDED AS SHOWN ON THE ARCHITECTURAL, MECHANICAL, FIRE PROTECTION, PLUMBING AND ELECTRICAL DRAWINGS AND BY EQUIPMENT MANUFACTURERS. INSTALLATION OF THESE ITEMS MUST BE COORDINATED AND PROVIDED FOR PRIOR TO PLACING CONCRETE.
C-9 OPENINGS IN CONCRETE SLABS AND/OR CONCRETE WALLS MUST HAVE ADDITIONAL REINFORCEMENT PER THE TYPICAL DETAILS. NO PENETRATIONS ARE PERMITTED THROUGH ANY CONCRETE BEAM, JOIST, COLUMN, PIER OR JAMB WITHOUT THE ENGINEER'S WRITTEN APPROVAL. PENETRATIONS MUST BE RE-ROUTED AS REQUIRED AT THESE LOCATIONS.
C-10 PENETRATIONS THROUGH CONCRETE SLABS AND/OR CONCRETE WALLS MUST BE PLACED DURING CONSTRUCTION OF THE WALL WITH THE APPROPRIATE SLEEVE.
C-11 REFER TO CONCRETE TABLES ON S-004 FOR ADDITIONAL INFORMATION.

MASONRY

- M-1 MASONRY WORK MUST BE IN CONFORMANCE WITH THE MASONRY SOCIETY (TMS) "BUILDING CODE REQUIREMENTS FOR MASONRY STRUCTURES — TMS 402" AND THE "SPECIFICATIONS FOR MASONRY STRUCTURES — TMS 602".
M-2 REINFORCEMENT AND EMBEDDED ITEMS:
A. REINFORCING TO BE DISCONTINUOUS AT CONTROL JOINTS UNLESS NOTED OTHERWISE. BOND BEAM REINFORCING AT THE TOPS AND BOTTOMS OF WALLS IS TO BE CONTINUOUS THROUGH JOINT.
B. DOWEL REINFORCED MASONRY WALLS TO FOUNDATION. SIZE DOWELS TO MATCH WALL REINFORCEMENT. LOCATE DOWELS IN CELLS TO CONTAIN WALL REINFORCEMENT. LAP DOWELS WITH WALL REINFORCEMENT PER MASONRY LAP TABLE.
C. UNLESS NOTED OTHERWISE, PLACE TYPICAL CMU REINFORCEMENT IN CENTER OF FULLY GROUTED CELLS AND SPACE AS FOLLOWS:
1. FOR 8" CMU: (1) #5 VERTICAL AT 32" ON CENTER, MINIMUM.
2. FOR 12" CMU: (1) #5 VERTICAL AT 24" ON CENTER, MINIMUM.
3. PROVIDE ADDITIONAL BARS AT CORNERS AND OPENINGS PER TYPICAL DETAILS.
D. VERTICAL REINFORCING TO BE HELD SECURELY IN PLACE DURING GROUT PLACEMENT TO PREVENT DISPLACEMENT OF REINFORCEMENT.
E. WELDING OF REINFORCEMENT IS PROHIBITED, UNLESS NOTED OTHERWISE.
F. PROVIDE EMBEDS (INCLUDING ANCHORS) FOR SUPPORTING STRUCTURAL AND NON-STRUCTURAL ELEMENTS INCLUDING BUT NOT LIMITED TO: HANDRAILS, CANOPIES, MISCELLANEOUS STEEL, ETC.
M-3 MASONRY ERECTION:
A. GROUT CELLS SOLID AT: INSERTS, ANCHORS, AND ELEVATOR GUIDE RAILS IN ADDITION TO LOCATIONS SHOWN IN THE TYPICAL DETAILS.
B. DO NOT FULLY GROUT WALLS UNLESS SPECIFICALLY CALLED OUT ON STRUCTURAL DRAWINGS.
C. CONTROL JOINT SPACING IN MASONRY WALLS MUST BE PROVIDED WHERE INDICATED ON THE STRUCTURAL DRAWINGS, OR A MAXIMUM OF 24'-0" ON CENTER.
D. MASONRY WALLS TO BE TEMPORARILY BRACED UNTIL FLOOR OR ROOF SYSTEM HAS BEEN INSTALLED AND HAS BECOME CAPABLE OF STABILIZING THE WALLS.
E. COORDINATE BLOCKOUTS, REVEALS, HOLES, OPENINGS AND BUILT-IN ITEMS WITH ALL CONTRACT DOCUMENTS AND DISCIPLINES.
F. PROVIDE VERTICAL MASONRY VENEER CONTROL JOINTS AS INDICATED ON THE ARCHITECTURAL DRAWINGS.
M-4 REFER TO MASONRY TABLES ON S-004 FOR ADDITIONAL INFORMATION.

POST-INSTALLED ANCHORS

- PI-1 ALL ADHESIVE OR MECHANICAL ANCHORS MUST BE INSTALLED, INCLUDING HOLE DRILLING, DRILL BIT TYPE, PREPARATION, AND CLEANING IN ACCORDANCE WITH AN APPROVED INDEPENDENT EVALUATION REPORT (ICC-ES, IAPMO, OR APPROVED EQUAL), THE PROJECT DRAWINGS AND SPECIFICATIONS, AND IN ACCORDANCE WITH ALL MANUFACTURER'S PRINTED INSTALLATION INSTRUCTIONS (MPII).
PI-2 POST-INSTALLED ANCHORS HAVE BEEN DESIGNED WITH HILTI ANCHORS (NOTED BELOW) AS THE BASIS OF DESIGN. PROVIDE APPROPRIATE ANCHOR WITH SIZE AND FINISH AS NOTED AND EQUIVALENT SHEAR AND TENSION CAPACITIES AFTER MODIFICATION DUE TO EMBEDMENT, SPACING AND EDGE DISTANCES. OTHER AVAILABLE MANUFACTURERS INCLUDE SIMPSON, ITW RED HEAD AND DEWALT.
A. EXPANSION ANCHORS: KWIK BOLT 3
B. SCREW ANCHORS: KH-EZ SCREW ANCHOR
C. ADHESIVE ANCHORS
1. CONCRETE: HIT HY-200
2. GROUTED CMU: HIT HY-270
D. SCREEN TUBE ANCHORS: HIT HY-270
PI-3 SUBSTITUTION REQUEST FOR ALTERNATIVE PRODUCTS MUST BE APPROVED IN WRITING BY THE STRUCTURAL ENGINEER PRIOR TO THE USE. SUBSTITUTION REQUEST MUST INCLUDE AN APPROVED INDEPENDENT EVALUATION REPORT (ICC-ES, IAPMO OR APPROVED EQUAL) AND SUPPORTING CALCULATIONS INDICATING COMPLIANCE WITH DESIGN INTENT. SUBSTITUTIONS MUST BE EVALUATED FOR THEIR COMPLIANCE WITH RELEVANT BUILDING CODES FOR SEISMIC USES, LOAD RESISTANCE, INSTALLATION CATEGORY, AND AVAILABILITY OF COMPREHENSIVE INSTALLATION INSTRUCTIONS. ADHESIVE ANCHOR EVALUATIONS MUST CONSIDER INSTALLED SUBSTITUTION ANCHORS IN CONCRETE MUST BE SUITABLE FOR USE IN CRACKED CONCRETE APPLICATIONS.
PI-4 DO NOT DISTURB, MAKE ATTACHMENTS, OR APPLY LOAD TO ADHESIVE ANCHORS PRIOR TO THE FULL CURE OF THE ADHESIVE. ADHESIVE ANCHORS MUST NOT BE FULLY LOADED UNTIL CONCRETE HAS REACHED 28-DAY DESIGN STRENGTH.
PI-5 CONCRETE TEMPERATURE AT THE TIME OF INSTALLATION MUST BE MONITORED BY THE CONTRACTOR. CONTRACTOR MUST COMPLY WITH ALL MANUFACTURER'S PRINTED INSTALLATION INSTRUCTIONS RELATIVE TO SUBSTRATE TEMPERATURE.

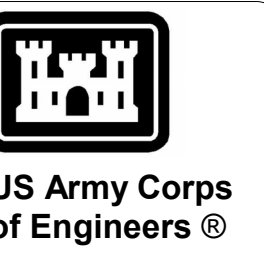

DATE

DESCRIPTION

MARK

US ARMY CORPS OF ENGINEERS
LOS ANGELES DISTRICT
DESIGNED BY: A. VALENZIA
DRAWN BY: R. CARLSON
CHECKED BY: D. CLAYSON
SUBMITTED BY: P. PASZCZUK
ISSUE DATE: NOVEMBER 13, 2025
SOLICITATION NO.: W812PL25RA0012
CONTRACT NO.: W812PL25C0037
KORTE CONSTRUCTION
5700 OAKLAND AVE. SUITE 275
ST. LOUIS, MO 63110
SIZE: ANS I D

GENERAL STRUCTURAL NOTES

SHEET ID
S-002

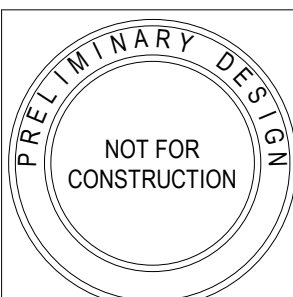

P
N
M
L
K
J
H
G
F
E
D
C
B
A

- PI-6 INSTALLATION OF ADHESIVE ANCHORS HORIZONTALLY OR UPWARDLY INCLINED TO SUPPORT SUSTAINED TENSION LOADS MUST BE PERFORMED BY PERSONNEL CERTIFIED BY AN APPLICABLE CERTIFICATION PROGRAM. CERTIFICATION MUST INCLUDE WRITTEN AND PERFORMANCE TEST IN ACCORDANCE WITH THE ACI/CRSI ADHESIVE ANCHOR INSTALLER CERTIFICATION PROGRAM, OR APPROVED EQUIVALENT, IN ACCORDANCE WITH ACI. PROOF OF CURRENT CERTIFICATION MUST BE SUBMITTED TO THE ENGINEER AND CONTRACTING OFFICER FOR APPROVAL PRIOR TO INSTALLATION. CONTINUOUS SPECIAL INSPECTION IS REQUIRED FOR THESE ANCHORS.
- PI-7 IF REINFORCING IS ENCOUNTERED DURING DRILLING, THAT HOLE IS TO BE ABANDONED. DO NOT DAMAGE REINFORCING TO MAINTAIN STRUCTURAL INTEGRITY OF SUBSTRATE COMPONENT. FILL ABANDONED HOLES WITH NON-SHRINK GROUT AND CONTACT THE STRUCTURAL ENGINEER FOR NEW LOCATIONS AND FURTHER INSTALLATION INSTRUCTIONS.
- PI-8 POST-INSTALLED ANCHORS TO BE GALVANIZED WHERE EXPOSED TO EXTERIOR AND/OR CORROSIVE ENVIRONMENTS UNLESS THE ANCHOR IS OTHERWISE PROTECTED.
- PI-9 SUBSTITUTION OF POST-INSTALLED ANCHORS FOR EMBEDDED ANCHORS SHOWN ON THE DRAWINGS IS NOT PERMITTED.

STRUCTURAL STEEL

- S-1 STRUCTURAL STEEL WORK IS TO BE DETAILED AND CONSTRUCTED IN ACCORDANCE WITH THE FOLLOWING STANDARD(S):
 - A. THE AMERICAN INSTITUTE OF STEEL CONSTRUCTION (AISC) 360 "SPECIFICATIONS FOR STRUCTURAL STEEL BUILDINGS"
 - B. THE AMERICAN INSTITUTE OF STEEL CONSTRUCTION (AISC) 341 "SEISMIC PROVISIONS FOR STRUCTURAL STEEL BUILDINGS"
- S-2 PRIOR TO FABRICATION, THE STEEL FABRICATOR IS TO SUBMIT TO THE CONTRACTING OFFICER FOR REVIEW SHOP DRAWINGS SHOWING ERECTION PLANS, PIECE DRAWINGS, AND CONNECTION DETAILS.
- S-3 STRUCTURAL STEEL FABRICATOR IS TO PROVIDE FOR VERTICAL AND HORIZONTAL FIELD ADJUSTMENT OF SUPPORT ASSEMBLIES.
- S-4 STEEL BEAMS ARE TO BE EQUALLY SPACED IN BAYS UNLESS OTHERWISE NOTED.
- S-5 FABRICATE AND INSTALL BEAMS WITH NATURAL CAMBER UP UNLESS CAMBER IS NOTED ON THE DRAWINGS.
- S-6 STRUCTURAL STEEL FRAMES AND TRUSSES ARE TO BE SECURELY BRACED UNTIL FLOOR SLABS, ROOF DECKS AND SHEAR WALLS HAVE BEEN INSTALLED AND BECOME CAPABLE OF STABILIZING THE FRAMES.
- S-7 UNLESS OTHERWISE NOTED, STRUCTURAL STEEL CONNECTIONS TO BE SHOP WELDED AND FIELD BOLTED.
- S-8 BOLTED CONNECTIONS:
 - A. BOLTS, TYPICAL: 3/4" MINIMUM DIAMETER ASTM F 3125 GR. A325N UNO WITH MATCHING WASHERS AND HEAVY HEX NUTS. BOLTS MUST BE INSTALLED IN A SNUG TIGHT CONDITION WHICH IS ACHIEVED WHEN CONNECTED PARTS ARE IN FIRM CONTACT.
 - B. DO NOT REUSE ANY BOLTS, NUTS, AND/OR WASHERS.
 - C. DO NOT APPLY ANY WELD TO BOLTS, NUTS, OR WASHERS UNO.
- S-9 WELDED CONNECTIONS:
 - A. USE E70XX ELECTRODES UNLESS OTHERWISE INDICATED ON THE DRAWINGS. E60XX MAY BE USED FOR WELDING COLD-FORMED STEEL DECKS AND FRAMING.
 - B. WELDING OF DEFORMED BAR ANCHORS AND/OR HEADED STUD ANCHORS IS TO BE IN ACCORDANCE WITH MANUFACTURER'S SPECIFICATIONS.
 - C. FILLET WELD SIZES NOT DESIGNATED MUST BE THE SAME AS THE THINNEST CONNECTED PARTS OR 1/4-INCH FILLET WELD ALL AROUND.
- S-10 SUBSTITUTION OF POST-INSTALLED ANCHORS FOR EMBEDDED ANCHORS SHOWN ON THE DRAWINGS IS NOT PERMITTED.
- S-11 PAINT AND PROTECTION:
 - A. EXPOSED STRUCTURAL STEEL TO RECEIVE PAINTED FINISH TO BE SHOP CLEANED AND PRIME PAINTED IN ACCORDANCE WITH SPECIFICATION SECTION 05 12 00 PART 2 - PRODUCTS. REFERENCE ARCHITECTURE FOR FINISH PAINT SYSTEMS.
 - B. EXPOSED STRUCTURAL STEEL FOR SCREEN WALLS, EQUIPMENT PLATFORMS, LOOSE ANGLE LINTELS ETC. TO BE HOT DIPPED GALVANIZED PER ASTM A 123
 - C. GALVANIZED FASTENERS AND ACCESSORIES TO BE HOT DIPPED GALVANIZED PER ASTM A 153/A 153M.
 - D. PROVIDE MINIMUM 3" CONCRETE COVER FOR STEEL BELOW GRADE.

MISCELLANEOUS STEEL

- MS-1 COORDINATE ALL MISCELLANEOUS STEEL ITEMS WITH STRUCTURAL STEEL NOTES.
- MS-2 PRIOR TO FABRICATION, THE STEEL FABRICATOR IS TO SUBMIT THE FOLLOWING TO THE CONTRACTING OFFICER FOR REVIEW:
 - A. SHOP DRAWINGS SHOWING ERECTION PLANS, PIECE DRAWINGS, AND CONNECTION DETAILS.
- MS-3 MANUFACTURE STEEL GRATING IN ACCORDANCE WITH THE "METAL BAR GRATING MANUAL" AS PUBLISHED BY THE NATIONAL ASSOCIATION OF ARCHITECTURAL METAL MANUFACTURERS.
 - A. STEEL FOR GRATING TO CONFORM TO ASTM A 1011/A 1011M. GRATING TO BE TYPE W-19-6 (1"x3/16") WITH GALVANIZED FINISH.
 - B. ALUMINUM FOR GRATING TO CONFORM TO ASTM B221. GRATING TO BE TYPE AS NOTED WITH MILL FINISH, UNO.

OPEN WEB STEEL JOISTS

- J-1 DESIGN, FABRICATION AND ERECTION OF OPEN WEB STEEL JOISTS MUST CONFORM TO THE STEEL JOIST INSTITUTE (SJI) "STANDARD SPECIFICATIONS AND LOAD TABLES FOR STEEL JOISTS AND JOIST GIRDERS."

- J-2 DESIGN ALL JOISTS, INCLUDING SLOPE, CAMBER AND BEARING ENDS. PROVIDE ALL BRIDGING LOCATIONS AND LAYOUTS. ALL DESIGNS MUST BE IN ACCORDANCE WITH SJI SPECIFICATIONS WITH A MAXIMUM DEFLECTION OF TL/180 AND LL/240.
- J-3 STEEL JOISTS ARE TO BE DESIGNED FOR ALL LOADS INDICATED AS WELL AS WIND UPLIFT AS SHOWN ON SHEET S-005.
- J-4 PROVIDE BRIDGING, BOTTOM CHORD EXTENSIONS AND ASSOCIATED ANCHORAGE IN ACCORDANCE WITH SJI REQUIREMENTS. BRIDGING, BOTTOM CHORD EXTENSIONS AND ASSOCIATED ANCHORAGE IS BY THE JOIST MANUFACTURER UNLESS NOTED OTHERWISE. WHERE ERECTION BRIDGING IS REQUIRED, HAVE IN PLACE A ROW OF BOLTED BRIDGING BEFORE RELEASING HOIST LINES.
- J-5 BOTTOM CHORD EXTENSIONS TO BE INSTALLED AS REQUIRED BY OSHA AND THE STEEL JOIST SUPPLIER. DO NOT FULLY CONNECT EXTENSIONS TO THE SUPPORTING STRUCTURE UNTIL APPLICABLE DEAD LOAD HAS BEEN APPLIED.
- J-6 STEEL JOIST MANUFACTURER IS TO PROVIDE ADDITIONAL BOTTOM CHORD BRIDGING FOR UPLIFT LOADS.
- J-7 PROVIDE ANCHORS AND FASTENERS REQUIRED FOR INSTALLATION OF JOISTS, BRIDGING AND BOTTOM CHORD EXTENSIONS.
- J-8 STEEL JOISTS ARE TO BE EQUALLY SPACED IN BAYS UNO. DO NOT EXCEED JOIST SPACING INDICATED ON THE DRAWINGS.
- J-9 JOIST SEATS HAVE BEEN ASSUMED TO BE AS LISTED BELOW, UNO. MODIFICATIONS TO THE STRUCTURE FOR ALTERNATE DEPTHS MUST BE COORDINATED BY THE GENERAL CONTRACTOR.
 - A. ALL SERIES: 5"
- J-10 HANGERS SUPPORTING MECHANICAL, ELECTRICAL OR OTHER EQUIPMENT ARE TO BE PLACED AT JOIST PANEL POINTS (WELDING NOT PERMITTED) AND APPLIED LOADS ARE TO BE COORDINATED WITH STEEL JOIST MANUFACTURER. DO NOT SUSPEND EQUIPMENT FROM BRIDGING OR METAL DECK.
- J-11 STEEL JOIST MANUFACTURER TO VERIFY SIZE, LOCATION AND WEIGHT OF SUPPORTED MECHANICAL UNITS AND ASSOCIATED OPENINGS PRIOR TO FABRICATION.

METAL DECK

- D-1 METAL DECK MUST BE DETAILED IN ACCORDANCE WITH THE STEEL DECK INSTITUTE (SDI) "DESIGN MANUAL FOR COMPOSITE DECKS, FORM DECKS AND ROOF DECKS".
- D-2 DECK UNITS HAVE BEEN DESIGNED TO BE A MINIMUM OF THREE (3) SPANS CONTINUOUS WITH LAPS PLACED OVER SUPPORTS.
- D-3 REFER TO ROOF DECK SCHEDULE ON S-603 WHICH INCLUDES DEPTH PROFILE, THICKNESS, AND ATTACHMENT.

LIGHT GAGE STEEL FRAMING

- LG-1 STRUCTURAL MEMBERS MUST BE DESIGNED IN ACCORDANCE WITH THE AMERICAN IRON AND STEEL INSTITUTE (AISI) "NORTH AMERICAN SPECIFICATION FOR THE DESIGN OF COLD-FORMED STEEL STRUCTURAL MEMBERS" (LATEST EDITION).
- LG-2 STRUCTURAL MEMBERS TO BE FORMED FROM CORROSION RESISTANT STEEL CONFORMING TO ASTM A 653/A 653M WITH MINIMUM YIELD STRESS (Fy) ACCORDING TO STRUCTURAL PERFORMANCE.
- LG-3 LIGHT GAGE MEMBERS AND DETAILS SHOWN ON THE ARCHITECTURAL OR STRUCTURAL DRAWINGS ARE FOR BID PURPOSES ONLY. STRUCTURAL STUD AND/OR JOIST FRAMING MEMBERS AND CONNECTIONS ARE TO BE ENGINEERED BY THE MANUFACTURER. DESIGN CALCULATIONS AND SHOP DRAWINGS INDICATING JAMBS, POSTS, HEADERS, BRACING AND PIECES NECESSARY FOR CONSTRUCTION MUST BE SUBMITTED TO THE CONTRACTING OFFICER FOR REVIEW. DESIGN CALCULATIONS ARE TO BE PREPARED BY OR UNDER THE SUPERVISION OF A PROFESSIONAL ENGINEER REGISTERED IN THE UNITED STATES AND BEARING THE SEAL OF THAT PROFESSIONAL ENGINEER.
- LG-4 MAXIMUM STUD SPACING TO BE 16" ON CENTER WITH DOUBLED STUDS (MINIMUM) AT EACH SIDE OF OPENINGS.
- LG-5 FRAMING COMPONENTS ARE TO BE CUT SQUARELY FOR ATTACHMENT TO PERPENDICULAR MEMBERS OR AS AN ANGULAR FIT AGAINST ABUTTING MEMBERS.
- LG-6 FIELD CUTTING OF STUDS MUST BE DONE BY SAWING OR SHEARING, TORCH CUTTING OF COLD-FORMED MEMBERS IS UNACCEPTABLE.
- LG-7 FASTENING OF COMPONENTS IS TO BE WITH SELF-DRILLING SCREWS OR WELDING. WELDING OF STUDS MUST COMPLY WITH AWS D1.3/D1.3M. WELDS TO BE TOUCHED-UP WITH ZINC-RICH PAINT. SCREWS AND WELDS TO BE OF SUFFICIENT SIZE TO ENSURE THE STRENGTH OF THE CONNECTION. WIRE TYING OF COMPONENTS IS NOT PERMITTED.
- LG-8 LIGHT GAGE STEEL FRAMING MEMBERS ARE TO BE SECURELY ATTACHED TO THE STRUCTURE WHERE INDICATED ON THE DRAWINGS OR APPROVED SHOP DRAWINGS. FASTENERS TO BE COMPATIBLE WITH THE STRUCTURAL MEMBERS. POWDER DRIVEN FASTENERS ARE NOT ACCEPTABLE FOR STRUCTURAL APPLICATIONS.
- LG-9 PROVIDE VERTICAL SLIDE TRACKS, OR SLIDE CLIPS, WHERE INDICATED ON THE DRAWINGS OR OTHERWISE REQUIRED TO ALLOW FOR VERTICAL STRUCTURAL MOVEMENTS. MAXIMUM EXPECTED STRUCTURE LIVE LOAD DEFLECTION IS L/360 AT FLOORS AND L/240 AT ROOFS.
- LG-10 REFERENCE ARCHITECTURAL DRAWINGS FOR ADDITIONAL INFORMATION, INCLUDING SHEATHING TYPE, FINISHES, OPENINGS, LOCATIONS ETC.

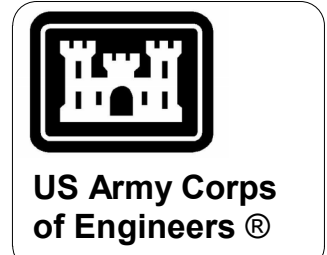

MARK	DESCRIPTION	DATE

DESIGNED BY: A. VALENIA	ISSUE DATE: NOVEMBER 13, 2025
DRAWN BY: R. CARLSON	SOLICITATION NO.: WB12PL25RA0012
CHECKED BY: D. CLAYSON	CONTRACT NO.: WB12PL25C0037
SUBMITTED BY: P. PASZCZUK	SIZE: ANSI D

US ARMY CORPS OF ENGINEERS LOS ANGELES DISTRICT	KORTE CONSTRUCTION 5700 OAKLAND AVE. SUITE 275 ST. LOUIS, MO 63110
--	--

CREECH AIR FORCE BASE, CLARK COUNTY, NV DISASTER RESILIENCY PROGRAM (DRP) - PHASE 2 494137	GENERAL STRUCTURAL NOTES
--	--------------------------

SHEET ID S-003

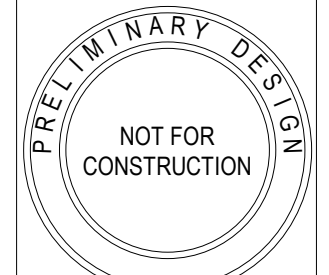

DP-1 95% SUBMISSION

P
N
M
L
K
J
H
G
F
E
D
C
B
A

CONCRETE REINFORCING DEVELOPMENT AND LAP SPLICE TABLE

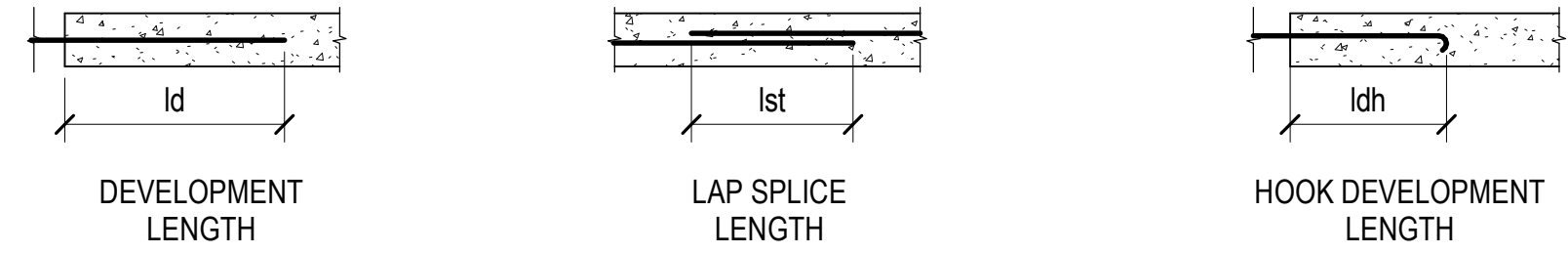

f _c = 4500 PSI										
BAR SIZE	#3	#4	#5	#6	#7	#8	#9	#10	#11	
ld (TOP BARS)	18	24	30	35	51	59	66	74	82	
ld (OTHER BARS)	14	18	23	27	40	45	51	57	64	
lst (TOP BARS)	24	32	39	46	67	77	86	97	107	
lst (OTHER BARS)	18	24	30	35	51	59	66	74	82	
ldh	12	12	12	14	17	19	21	24	27	

f _c = 5000 PSI										
BAR SIZE	#3	#4	#5	#6	#7	#8	#9	#10	#11	
ld (TOP BARS)	17	23	28	34	49	56	63	71	78	
ld (OTHER BARS)	13	17	22	26	38	43	48	54	60	
lst (TOP BARS)	23	30	37	45	64	73	82	93	102	
lst (OTHER BARS)	17	23	28	34	49	56	63	71	78	
ldh	12	12	12	14	16	18	20	23	25	

- NOTES:**
- LENGTHS SHOWN ARE IN INCHES.
 - LENGTHS SHOWN ABOVE ARE FOR SINGLE REINFORCING BARS WITH MAXIMUM YIELD STRENGTH OF 60KSI.
 - LENGTHS SHOWN ASSUME CLEAR SPACING OF BARS ARE AT LEAST 2 TIMES BAR DIAMETER AND CLEAR COVER OF AT...
 - LENGTHS SHOWN ABOVE ARE FOR NORMAL WEIGHT CONCRETE. FOR LIGHT WEIGHT CONCRETE, MULTIPLY VALUES BY...
 - FOR EPOXY COATED BARS, MULTIPLY VALUES BY 1.5.
 - WHEN SPLICING BARS OF DIFFERENT SIZES, USE SPLICE LENGTH FOR LARGER BAR.
 - SPLICES (LAPS) OF REINFORCING BARS MUST BE CLASS 'B' TENSION LAPS PER ACI 318, UNLESS NOTED OTHERWISE. lst VALUES ABOVE TO BE DIVIDED BY 1.3 FOR CLASS 'A' SPLICE.
 - TOP BARS ARE HORIZONTAL REINFORCING BARS WITH 12 INCHES OR MORE OF FRESH CONCRETE IS PLACED BELOW.
 - OTHER BARS ARE ANY REINFORCING BARS THAT DO NOT MEET QUALIFICATION FOR TOP BARS.

ELEMENT	f _c (PSI), WEIGHT	EXPOSURE CLASS (NOTES 1 & 2)
FOOTINGS	4500, NW	F0, S2, W0, C1
FOUNDATION (STEM) WALLS	4500, NW	F1, S2, W0, C1
ADMIN INTERIOR SLAB ON GRADE	4500, NW	F0, S2, W0, C0
HANGAR BAY INTERIOR SLAB ON GRADE	5000, NW	F0, S2, W0, C1
EXTERIOR SLABS	4500, NW	F1, S2, W0, C1
LEVELING GROUT	5000, NW	

- NOTES:**
- EXPOSURE CLASS INDICATES THE SEVERITY OF THE ANTICIPATED EXPOSURE OF CONCRETE MEMBERS, IN ACCORDANCE WITH ACI 318, CHAPTER 18.
 - PROVIDE TYPE V OR EQUIVALENT SULFATE RESISTANT CEMENT (AS APPROVED BY THE ENGINEER) IN ALL CONCRETE.
 - CONCRETE STRENGTH, f_c, IS THE COMPRESSIVE STRENGTH AT 28 DAYS UNLESS NOTED OTHERWISE.
 - NORMAL WEIGHT (NW) CONCRETE SHALL HAVE A DRY DENSITY OF 145 ±4 PCF, UNO. LIGHTWEIGHT CONCRETE (LW) MUST HAVE A DRY DENSITY OF 115 ±5 PCF UNO.
 - MIX DESIGNS MUST BE IN ACCORDANCE WITH ACI 301.
 - WHERE CONCRETE IS EXPOSURE CLASS F3, RESTRICTIONS ON MAXIMUM FLY ASH AND/OR OTHER CEMENTITIOUS MATERIALS APPLY. REFER TO ACI 318, TABLE 26.4.2.2(B) FOR REQUIREMENTS.
 - AIR CONTENT FOR F1 EXPOSURE MUST BE BETWEEN 4.5% TO 6% UNLESS APPROVED OTHERWISE BY THE ENGINEER. THERE IS NO AIR CONTENT REQUIREMENT FOR THE F0 EXPOSURE CONCRETE.
 - MAXIMUM W/C RATIO MUST NOT BE EXCEEDED. APPROVED ADMIXTURES SUCH AS PLASTICIZERS MAY BE USED ON SITE.
 - CONCRETE FLEXURAL STRENGTH OF HANGAR BAY SOG WILL BE 550 PSI MIN AND 650 PSI MAX AT 90 DAYS.

MASONRY STRENGTH TABLE	
ELEMENT	SPECIFIED COMPRESSIVE STRENGTH
CONCRETE MASONRY	f _m = 2000 PSI
GROUT FOR CONCRETE MASONRY	f _g ≥ f _m (2000 PSI MINIMUM)

- NOTES:**
- PROVIDE MEDIUM WEIGHT HOLLOW CONCRETE MASONRY UNITS FOR GENERAL USE UNLESS OTHERWISE NOTED.
 - MORTAR FOR CONCRETE MASONRY MUST BE TYPE S AT EXTERIOR WALLS AND TYPE N AT INTERIOR WALLS.

BAR SIZE	SINGLE REINFORCING			DOUBLE REINFORCING		
	8" CMU	10" CMU	12" CMU	8" CMU	10" CMU	12" CMU
#3	12	12	12	13	13	13
#4	13	12	12	22	22	22
#5	19	16	13	35	35	35
#6	37	29	24	54	54	54
#7	-	40	33	-	63	63
#8	-	-	50	-	-	72

- NOTES:**
- LAP SPLICE LENGTHS ARE IN INCHES.
 - LAP SPLICES IN REINFORCED MASONRY MUST HAVE MINIMUM LENGTHS AS DEFINED ABOVE UNLESS NOTED OTHERWISE
 - TABULATED VAULES ARE CALCUATED IN ACCORDANCE WITH TMS 402/602-16 CHAPTER 6.
 - SPLICE AND DEVELOPMENT LENGTHS ARE THE SAME VALUE FOR HORIZONTAL AND VERTICAL BARS
 - SINGLE REINFORCING IS A SINGLE BAR CENTERED IN CMU BLOCK CELL. DOUBLE REINFORCING IS TWO BARS IN A CMU BLOCK CELL WITH 2 INCH MINIMUM CLEAR COVER FROM OUTSIDE FACE OF BLOCK.
 - TABULATED VALUES BASED ON UNCOATED REINFORCEMENT WITH A YEILD STRENGTH, F_y =60 KSI
 - TABULATED VALUES BASED ON MASONRY COMPRESSIVE STRENGTH, f_m =2000 PSI

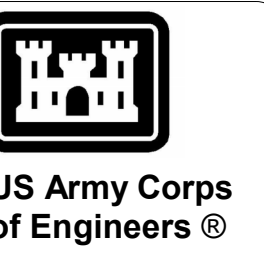

US Army Corps of Engineers®

MARK	DESCRIPTION	DATE

DESIGNED BY: A. VALENCIA	ISSUE DATE: NOVEMBER 13, 2025
DRAWN BY: R. CARLSON	SOLICITATION NO.: WB12PL25RA0012
CHECKED BY: D. CLAYSON	CONTRACT NO.: WB12PL25C0037
SUBMITTED BY:	SIZE: ANSI D

US ARMY CORPS OF ENGINEERS
LOS ANGELES DISTRICT

KORTE CONSTRUCTION
5700 OAKLAND AVE. SUITE 275
ST. LOUIS, MO 63110

CREECH AIR FORCE BASE, CLARK COUNTY, NV
DISASTER RESILIENCY PROGRAM (DRP) - PHASE 2
494137

GENERAL STRUCTURAL NOTES

SHEET ID
S-004

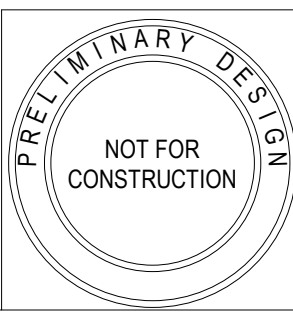

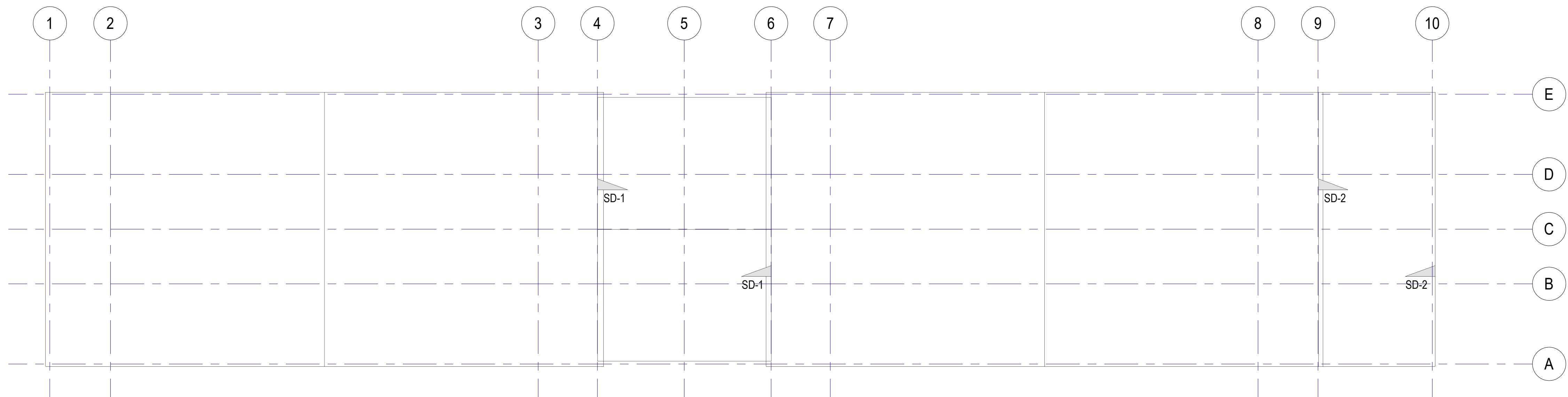

K3 OVERALL ROOF SNOW DRIFT LOAD PLAN
1" = 30'-0"

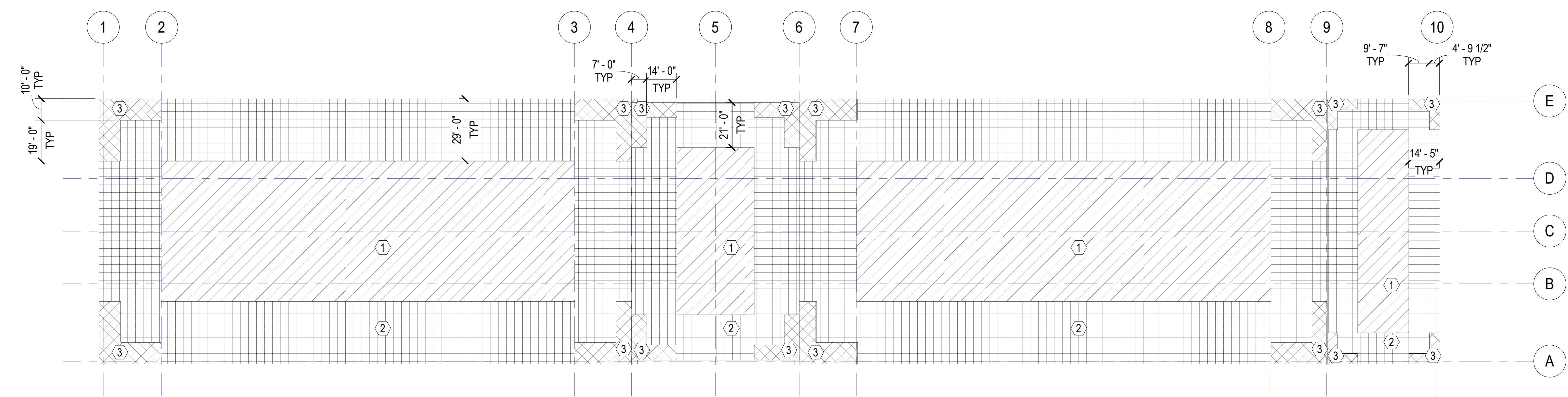

D3 OVERALL WIND COMPONENTS AND CLADDING ROOF LOAD PLAN
1" = 30'-0"

SNOW DRIFT LOAD KEY			
MARK	SURCHARGE LOAD (Pd)	DRIFT WIDTH (d)	BALANCED SNOW LOAD (Pf)
SD-1	41.8 psf	10 ft	21 psf
SD-2	29.9 psf	23 ft	3.9 psf

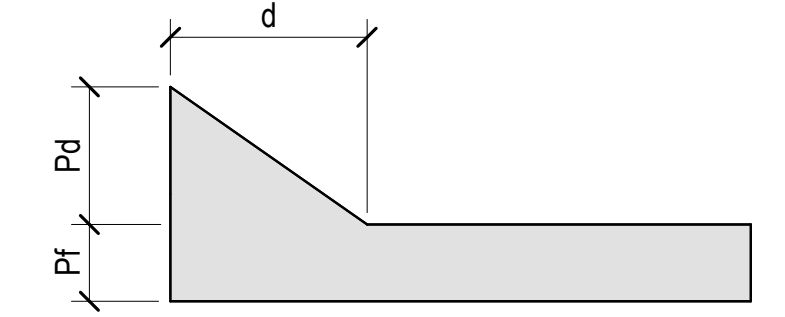

WIND LOAD MAP KEY					
MARK	PATTERN	USAGE	WIND LOAD (psf)		
			50 ft ²	100 ft ²	500 ft ²
①	[Diagonal Hatching]	COMPONENTS AND CLADDING PRESSURES (ULTIMATE)			
①	[Diagonal Hatching]	INTERIOR ROOF ZONE (ZONE 1)	-50.8 23.0	-47.6 23.0	-40.1 23.0
②	[Horizontal Hatching]	ROOF END ZONE (ZONE 2)	-67.0 23.0	-60.1 23.0	-50.5 23.0
③	[Cross-hatching]	ROOF END ZONE (ZONES 3)	-77.9 23.0	-69.7 23.0	-50.5 23.0

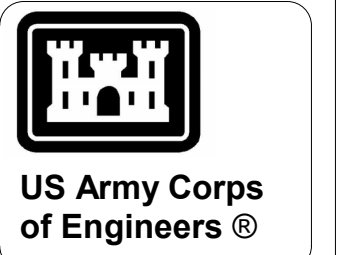
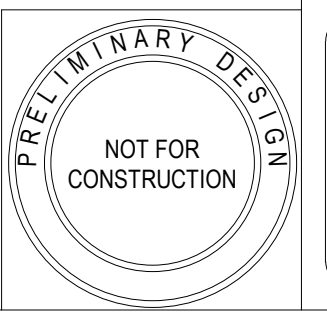
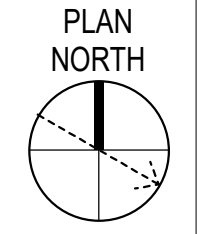
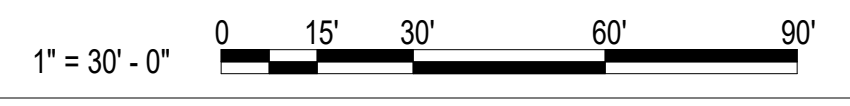
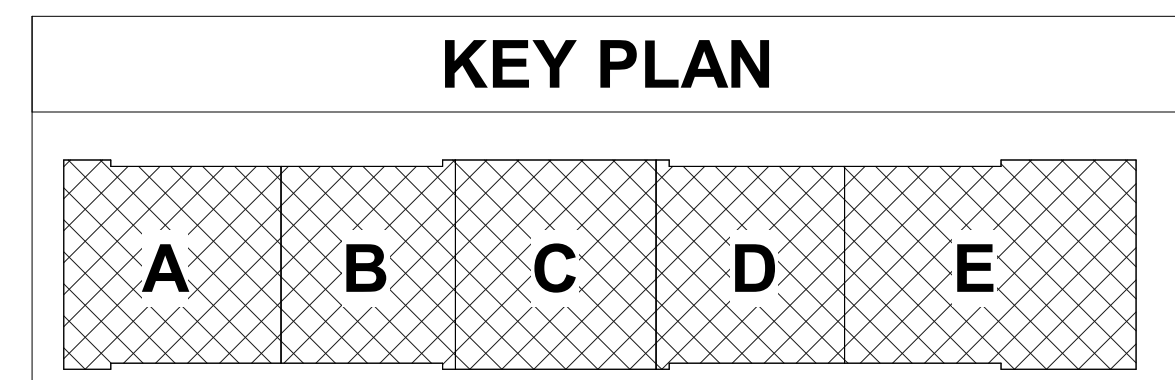

MARK	DESCRIPTION	DATE

ISSUE DATE: NOVEMBER 13, 2025	SOLICITATION NO.: W812PL253RA0012	CONTRACT NO.: W812PL25C0037
DESIGNED BY: A. VALENCIA	DRAWN BY: R. CARLSON	CHECKED BY: D. CLAYSON
US ARMY CORPS OF ENGINEERS LOS ANGELES DISTRICT	KORTE CONSTRUCTION 5700 OAKLAND AVE. SUITE 275 ST. LOUIS, MO 63110	
ANSI D	SUBMITTED BY: P. PASZCZUK	

CREECH AIR FORCE BASE, CLARK COUNTY, NV
DISASTER RESILIENCY PROGRAM (DRP) - PHASE 2
494137
LOADING PLANS

SHEET ID
S-005

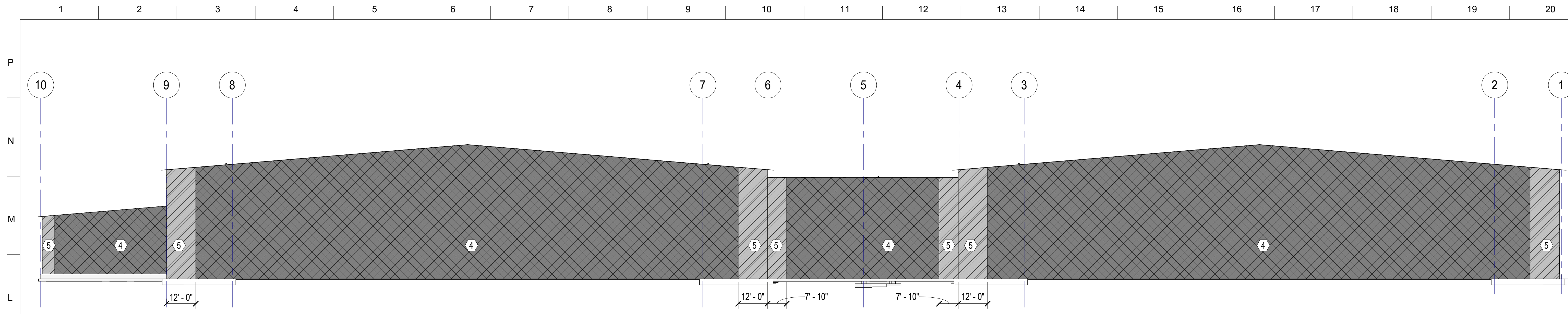

K1 WIND LOAD ELEVATION - NORTH FACE
3/64" = 1'-0"

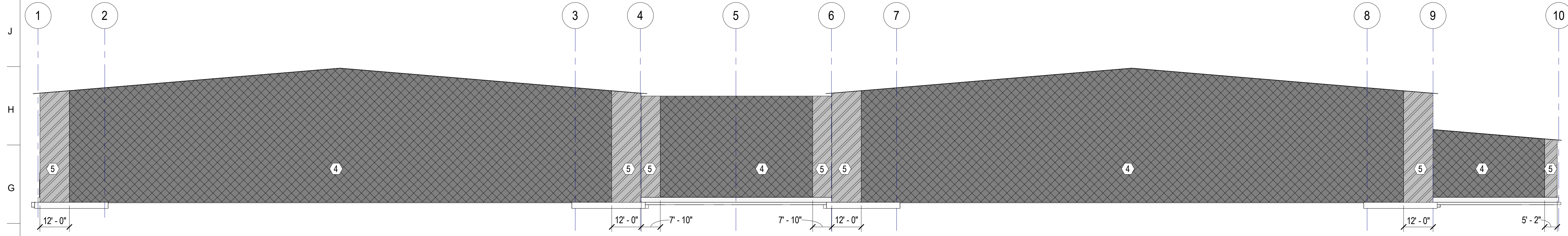

F1 WIND LOAD ELEVATION - SOUTH FACE
3/64" = 1'-0"

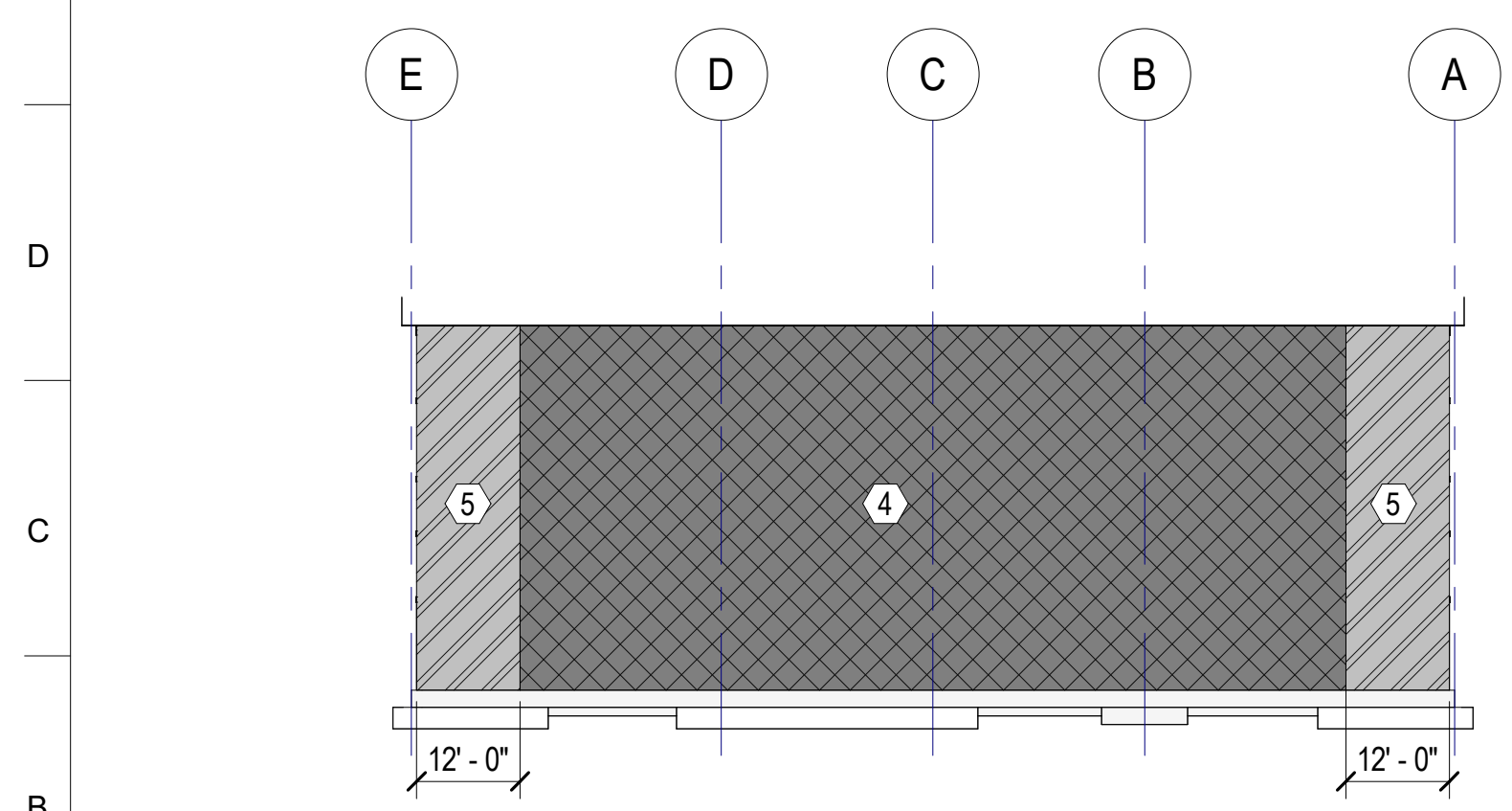

B1 WIND LOAD ELEVATION - WEST FACE
3/64" = 1'-0"

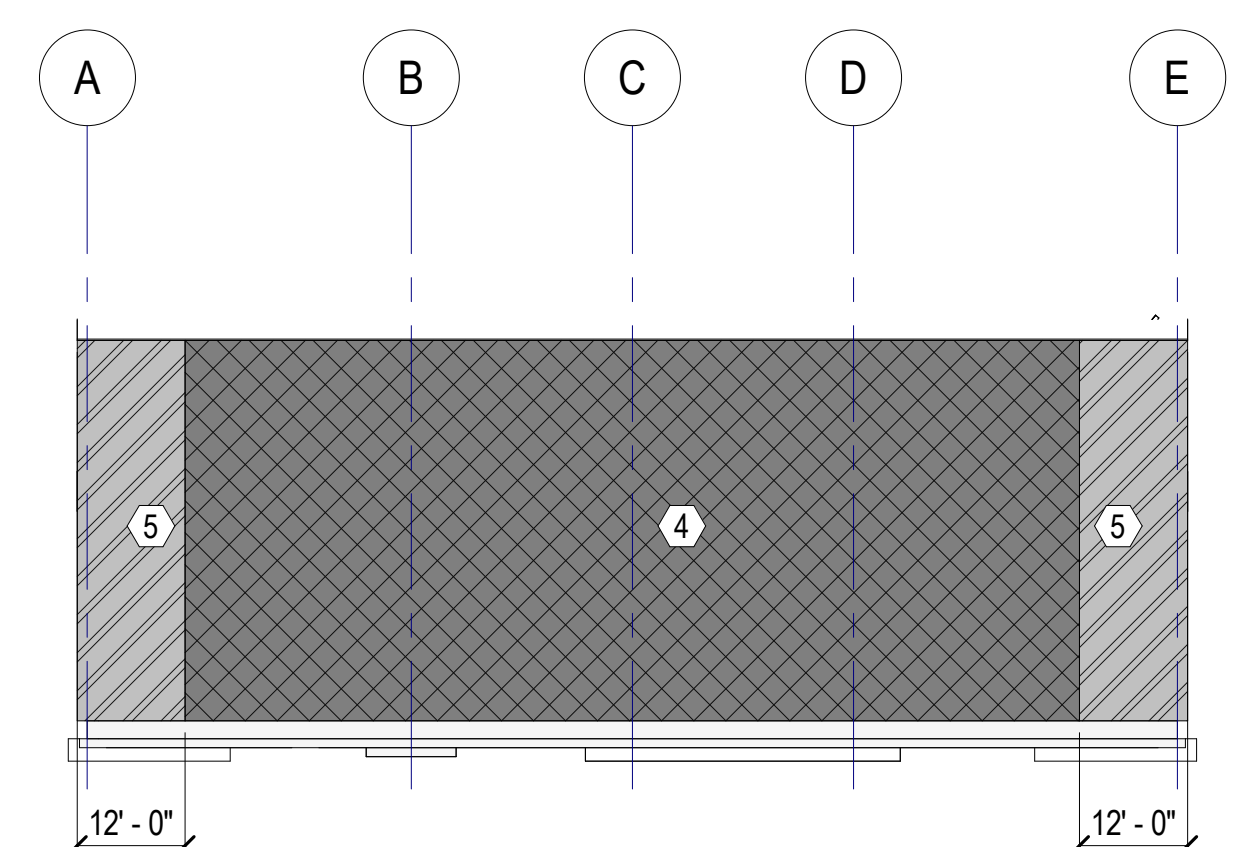

B7 WIND LOAD ELEVATION - EAST FACE
3/64" = 1'-0"

WIND LOAD MAP KEY					
MARK	PATTERN	USAGE	WIND LOAD (psf)		
			10 ft ²	100 ft ²	200 ft ²
④		COMPONENTS AND CLADDING PRESSURES (ULTIMATE)	-39.9 +37.5	-35.8 +33.4	-34.5 +32.2
⑤		INTERIOR WALL ZONE (ZONE 4)	-46.9 +37.5	-38.6 +33.4	-36.2 +32.2

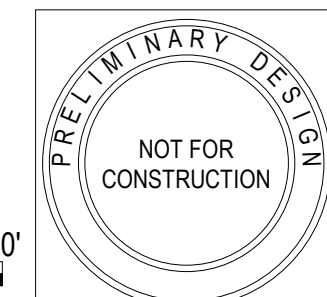

US Army Corps of Engineers®

MARK	DESCRIPTION	DATE

DESIGNED BY: A. VALENCIA	ISSUE DATE: NOVEMBER 13, 2025
DRAWN BY: R. CARLSON	SOLICITATION NO.: W812PL25RA0012
CHECKED BY: D. CLAYSON	CONTRACT NO.: W812PL25C0037
SUBMITTED BY: P. PASZCZUK	ANSI D

US ARMY CORPS OF ENGINEERS
LOS ANGELES DISTRICT

KORTE CONSTRUCTION
5700 OAKLAND AVE. SUITE 275
ST. LOUIS, MO 63110

CREECH AIR FORCE BASE, CLARK COUNTY, NV
DISASTER RESILIENCY PROGRAM (DRP) - PHASE 2
494137

WIND LOADING ELEVATIONS

SHEET ID
S-006

DP-1 95% SUBMISSION

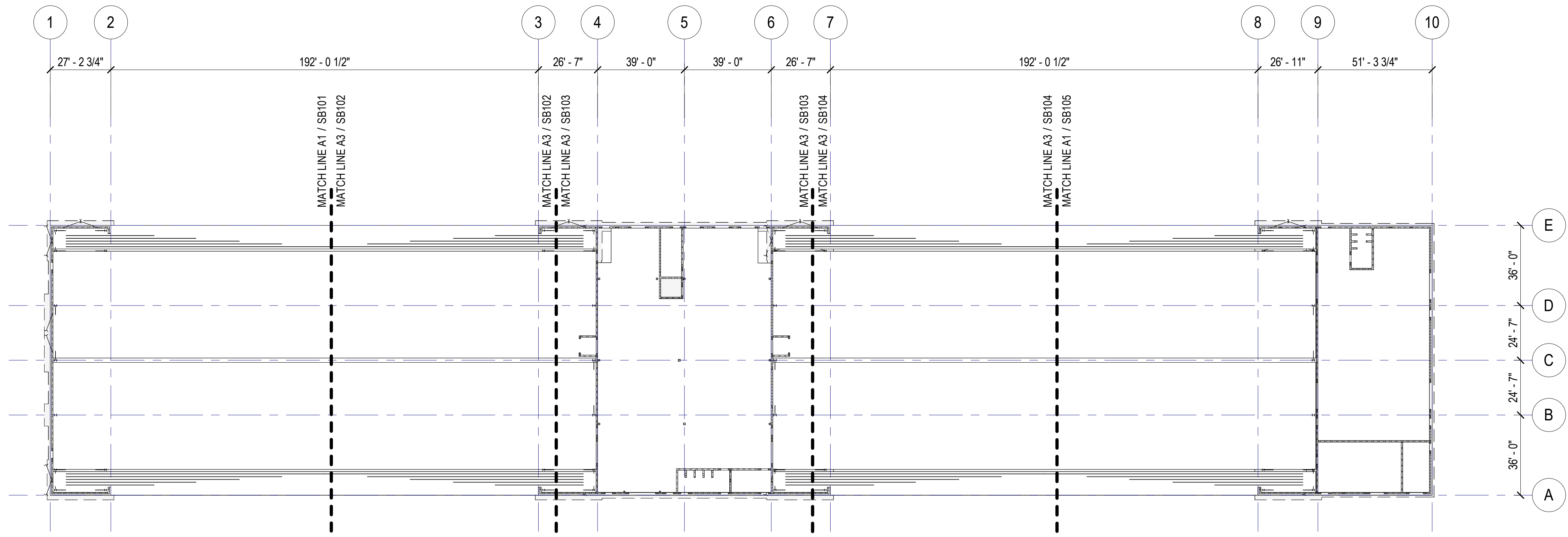

D2 OVERALL FOUNDATION PLAN
SCALE: 1" = 30'-0"

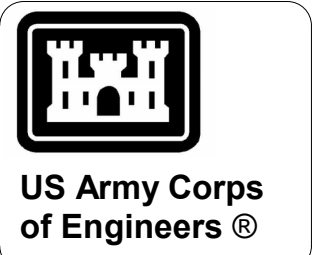
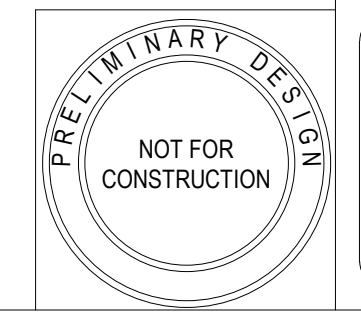
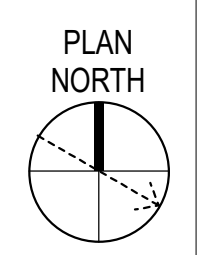
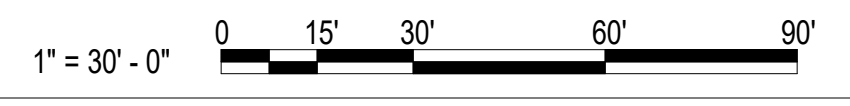
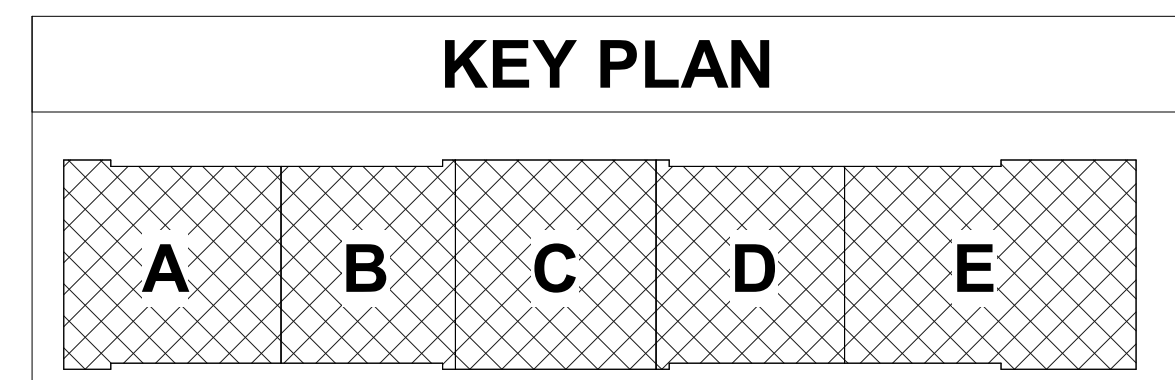

MARK	DESCRIPTION	DATE

DESIGNED BY: A. VALENCIA	ISSUE DATE: NOVEMBER 13, 2025
DRAWN BY: R. CARLSON	SOLICITATION NO.: W812PL25RA0012
CHECKED BY: D. CLAYSON	CONTRACT NO.: W812PL25C0037
SUBMITTED BY: P. PASZCZUK	SIZE: ANSI D

US ARMY CORPS OF ENGINEERS
LOS ANGELES DISTRICT

KORTE CONSTRUCTION
5700 OAKLAND AVE. SUITE 275
ST. LOUIS, MO 63110

CREECH AIR FORCE BASE, CLARK COUNTY, NV
DISASTER RESILIENCY PROGRAM (DRP) - PHASE 2
494137

OVERALL FOUNDATION PLAN

SHEET ID
SB100

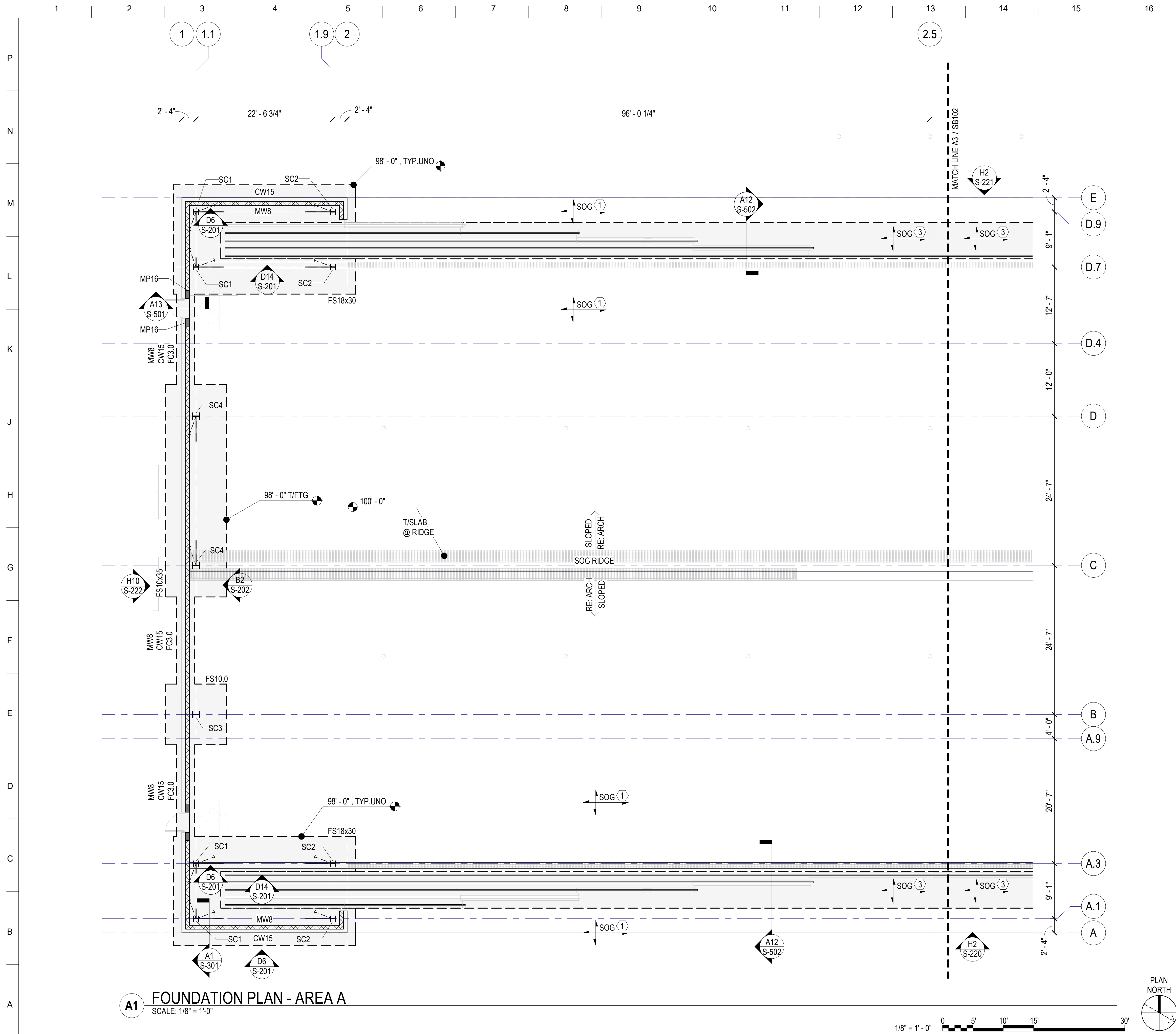

A1 FOUNDATION PLAN - AREA A
SCALE: 1/8" = 1'-0"

GENERAL NOTES

- SEE SHEETS S-001 TO S-005 FOR GENERAL NOTES AND DESIGN CRITERIA.
- SEE ARCHITECTURAL, CIVIL, AND LANDSCAPE DRAWINGS FOR EXTERIOR CONCRETE WORK AT DOORS, SIDEWALKS, ETC.
- TYPICAL TOP OF SLAB ELEVATION = RE: CIVIL AND ARCH. THIS IS THE DATUM 100'-0". ALL ELEVATIONS ARE REFERENCED FROM THIS ELEVATION.
- FOUNDATIONS ARE SPREAD, STRIP, MAT FOOTINGS. ALL FOOTINGS TO BE CENTERED BELOW WALLS AND COLUMNS (OR COLUMN GROUP) UNLESS NOTED OTHERWISE.
- ALL TOP OF FOOTING ELEVATIONS = 98'-0" UNLESS NOTED OTHERWISE.
- ALL EXTERIOR FOOTINGS MUST BEAR AT OR BELOW MINIMUM BEARING DEPTH AS SPECIFIED IN DESIGN CRITERIA SECTION. PROVIDE ADDITIONAL FOOTING STEPS AS REQUIRED. CONTRACTOR SHALL COORDINATE ALL FOOTING STEP LOCATIONS.
- RE: PLAN FOR SLAB ON GRADE THICKNESS AND REINFORCING.
- FOR DIMENSIONS NOT SHOWN ON THESE SHEETS, COORDINATE WALL OPENINGS, ELEVATIONS, SECTIONS, AND DETAILS WITH ARCHITECTURAL, MECHANICAL, ELECTRICAL, AND PLUMBING DRAWINGS.
- FOR UTILITIES PASSING BELOW FOOTINGS, SEE L17/S-501. CONTRACTOR MUST COORDINATE ALL UTILITY AND FOOTING STEP LOCATIONS. SEE L13/S-501 FOR TYPICAL FOOTING STEP DETAIL AND D9/S-501 FOR UTILITY PENETRATION THROUGH FOUNDATION WALLS.
- ALL FOOTINGS AT THE END OF A WALL THAT DOES NOT END IN A CORNER CONDITION SHALL EXTEND 1'-0" PAST WALL END.
- CMU WALLS ARE MW8 UNLESS NOTED OTHERWISE.
- CONCRETE STEM WALLS ARE CW8 UNDER MW8 CMU AND CW15 UNDER MW8 WALLS WITH CMU VENEER UNLESS NOTED OTHERWISE.
- RE: ARCH DRAWINGS FOR SLAB SLOPES AND DRAINS, ETC.

KEYNOTES

- 12 1/2" THICK UNREINFORCED SLAB ON GRADE ON 15 MIL VAPOR RETARDER OVER 6" MIN OF CRUSHED STONE AGGREGATE AND 12" MIN COMPACTED NON-EXPANSIVE FILL (SEE GEOTECH REPORT). SLAB ON GROUND JOINTS MUST BE LOCATED NO GREATER THAN 20 FT ON CENTER EACH DIRECTION, RE: E6/S-502 AND E10/S-502.)
- 6" THICK REINFORCED SLAB ON GRADE W/ # 4 @ 18" OC EACH WAY ON 15 MIL VAPOR RETARDER OVER 6" MIN OF CRUSHED STONE AGGREGATE AND 12" MIN COMPACTED NON-EXPANSIVE FILL (SEE GEOTECH REPORT). SLAB ON GROUND JOINTS MUST BE LOCATED NO GREATER THAN 15 FT ON CENTER EACH DIRECTION, RE: E6/S-502 AND E10/S-502.)
- 8" THICK UNREINFORCED CONC. SLAB OVER CONC. MAT FOOTING AT HANGAR DOOR SUPPORT RAILS. RE: A12/S-502
- RE: H9/S-501 FOR SLAB REINFORCING AT OPENINGS AND RE-ENTRANT CORNERS, TYP

TRENCH DRAIN COORDINATION AND DETAILS IN PROGRESS

KEY PLAN

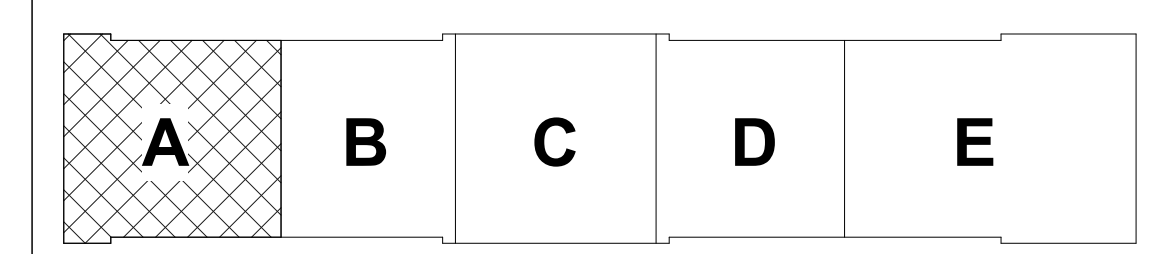

MARK	DESCRIPTION	DATE

DESIGNED BY: A. VALENCIA	ISSUE DATE: NOVEMBER 13, 2025
DRAWN BY: R. CARLSON	SOLICITATION NO.:
CHECKED BY: D. CLAYSON	WB12PL25RA0012
SUBMITTED BY: P. PASZCZUK	CONTRACT NO.:
SIZE: ANSI D	WB12PL25C0037

US ARMY CORPS OF ENGINEERS
LOS ANGELES DISTRICT

KORTE CONSTRUCTION
5700 OAKLAND AVE. SUITE 275
ST. LOUIS, MO 63110

CREECH AIR FORCE BASE, CLARK COUNTY, NV
DISASTER RESILIENCY PROGRAM (DRP) - PHASE 2
494137

FOUNDATION PLAN - AREA A

SHEET ID
SB101

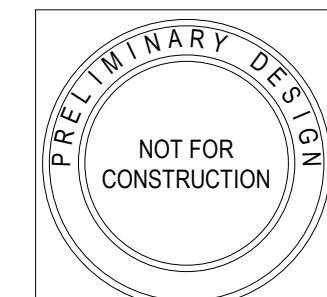

DP-1 95% SUBMISSION

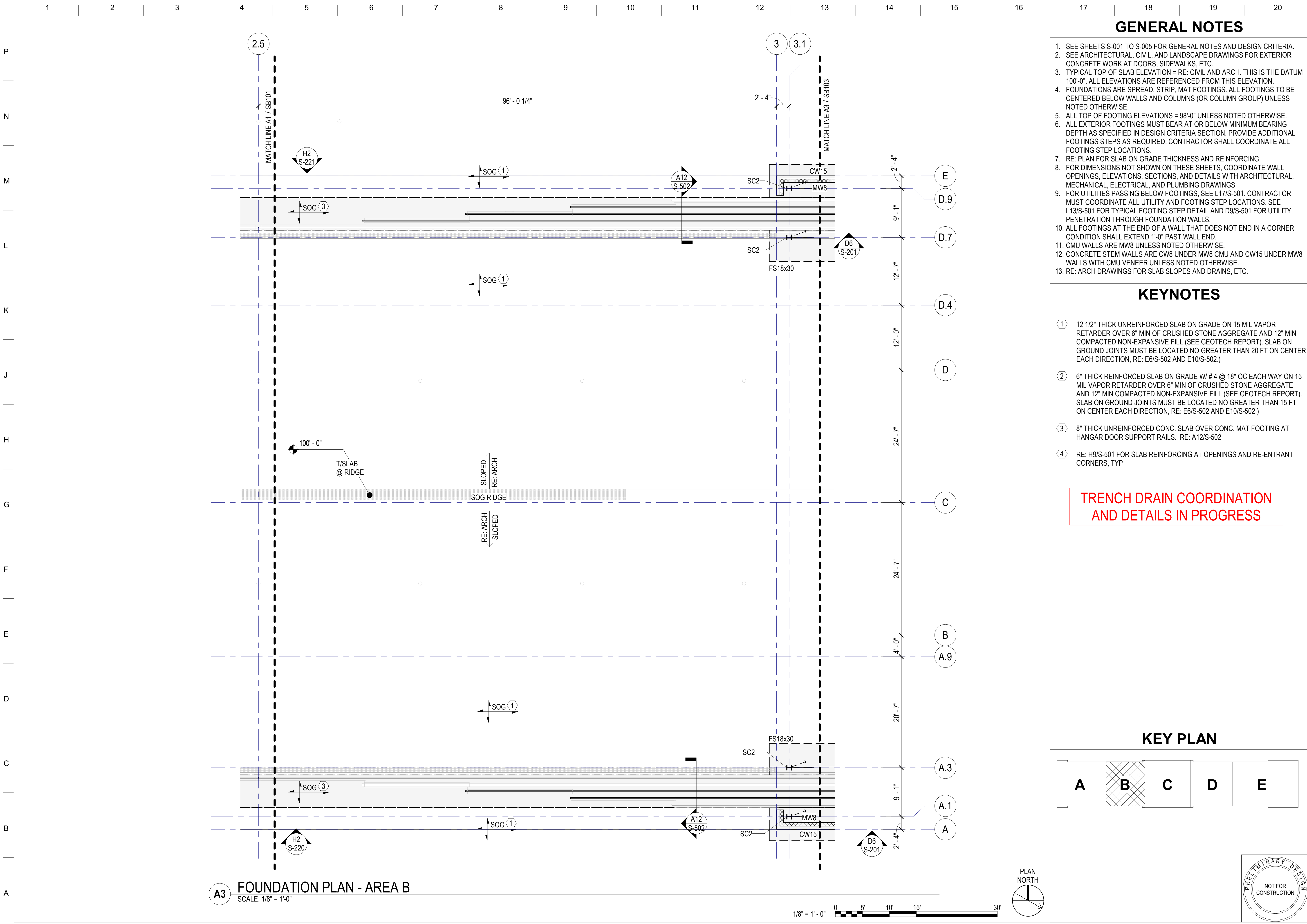

A3 FOUNDATION PLAN - AREA B
SCALE: 1/8" = 1'-0"



GENERAL NOTES

1. SEE SHEETS S-001 TO S-005 FOR GENERAL NOTES AND DESIGN CRITERIA.
2. SEE ARCHITECTURAL, CIVIL, AND LANDSCAPE DRAWINGS FOR EXTERIOR CONCRETE WORK AT DOORS, SIDEWALKS, ETC.
3. TYPICAL TOP OF SLAB ELEVATION = RE: CIVIL AND ARCH. THIS IS THE DATUM 100'-0". ALL ELEVATIONS ARE REFERENCED FROM THIS ELEVATION.
4. FOUNDATIONS ARE SPREAD, STRIP, MAT FOOTINGS. ALL FOOTINGS TO BE CENTERED BELOW WALLS AND COLUMNS (OR COLUMN GROUP) UNLESS NOTED OTHERWISE.
5. ALL TOP OF FOOTING ELEVATIONS = 98'-0" UNLESS NOTED OTHERWISE.
6. ALL EXTERIOR FOOTINGS MUST BEAR AT OR BELOW MINIMUM BEARING DEPTH AS SPECIFIED IN DESIGN CRITERIA SECTION. PROVIDE ADDITIONAL FOOTING STEPS AS REQUIRED. CONTRACTOR SHALL COORDINATE ALL FOOTING STEP LOCATIONS.
7. RE: PLAN FOR SLAB ON GRADE THICKNESS AND REINFORCING.
8. FOR DIMENSIONS NOT SHOWN ON THESE SHEETS, COORDINATE WALL OPENINGS, ELEVATIONS, SECTIONS, AND DETAILS WITH ARCHITECTURAL, MECHANICAL, ELECTRICAL, AND PLUMBING DRAWINGS.
9. FOR UTILITIES PASSING BELOW FOOTINGS, SEE L17/S-501. CONTRACTOR MUST COORDINATE ALL UTILITY AND FOOTING STEP LOCATIONS. SEE L13/S-501 FOR TYPICAL FOOTING STEP DETAIL AND D9/S-501 FOR UTILITY PENETRATION THROUGH FOUNDATION WALLS.
10. ALL FOOTINGS AT THE END OF A WALL THAT DOES NOT END IN A CORNER CONDITION SHALL EXTEND 1'-0" PAST WALL END.
11. CMU WALLS ARE MW8 UNLESS NOTED OTHERWISE.
12. CONCRETE STEM WALLS ARE CW8 UNDER MW8 CMU AND CW15 UNDER MW8 WALLS WITH CMU VENEER UNLESS NOTED OTHERWISE.
13. RE: ARCH DRAWINGS FOR SLAB SLOPES AND DRAINS, ETC.

KEYNOTES

- ① 12 1/2" THICK UNREINFORCED SLAB ON GRADE ON 15 MIL VAPOR RETARDER OVER 6" MIN OF CRUSHED STONE AGGREGATE AND 12" MIN COMPACTED NON-EXPANSIVE FILL (SEE GEOTECH REPORT). SLAB ON GROUND JOINTS MUST BE LOCATED NO GREATER THAN 20 FT ON CENTER EACH DIRECTION, RE: E6/S-502 AND E10/S-502.)
- ② 6" THICK REINFORCED SLAB ON GRADE W/ #4 @ 18" OC EACH WAY ON 15 MIL VAPOR RETARDER OVER 6" MIN OF CRUSHED STONE AGGREGATE AND 12" MIN COMPACTED NON-EXPANSIVE FILL (SEE GEOTECH REPORT). SLAB ON GROUND JOINTS MUST BE LOCATED NO GREATER THAN 15 FT ON CENTER EACH DIRECTION, RE: E6/S-502 AND E10/S-502.)
- ③ 8" THICK UNREINFORCED CONC. SLAB OVER CONC. MAT FOOTING AT HANGAR DOOR SUPPORT RAILS. RE: A12/S-502
- ④ RE: H9/S-501 FOR SLAB REINFORCING AT OPENINGS AND RE-ENTRANT CORNERS, TYP

TRENCH DRAIN COORDINATION AND DETAILS IN PROGRESS

KEY PLAN

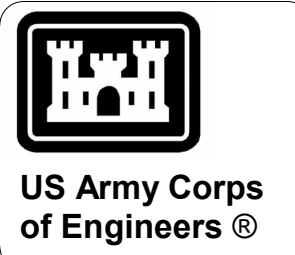
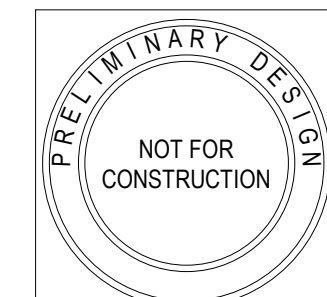
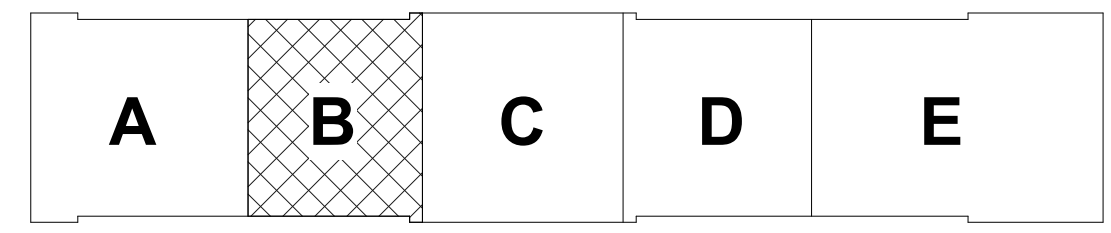

MARK	DESCRIPTION	DATE

ISSUE DATE: NOVEMBER 13, 2025	DESIGNED BY: A. VALENCIA
SOLICITATION NO.: W812PL25RA0012	DRAWN BY: R. CARLSON
CONTRACT NO.: W812PL25C0037	CHECKED BY: D. CLAYSON
	SUBMITTED BY: P. PASZCZUK
	SIZE: ANSI D

US ARMY CORPS OF ENGINEERS
LOS ANGELES DISTRICT

KORTE CONSTRUCTION
5700 OAKLAND AVE. SUITE 275
ST. LOUIS, MO 63110

CREECH AIR FORCE BASE, CLARK COUNTY, NV
DISASTER RESILIENCY PROGRAM (DRP) - PHASE 2
494137

FOUNDATION PLAN - AREA B

SHEET ID
SB102

DP-1 95% SUBMISSION

P
N
M
L
K
J
H
G
F
E
D
C
B
A

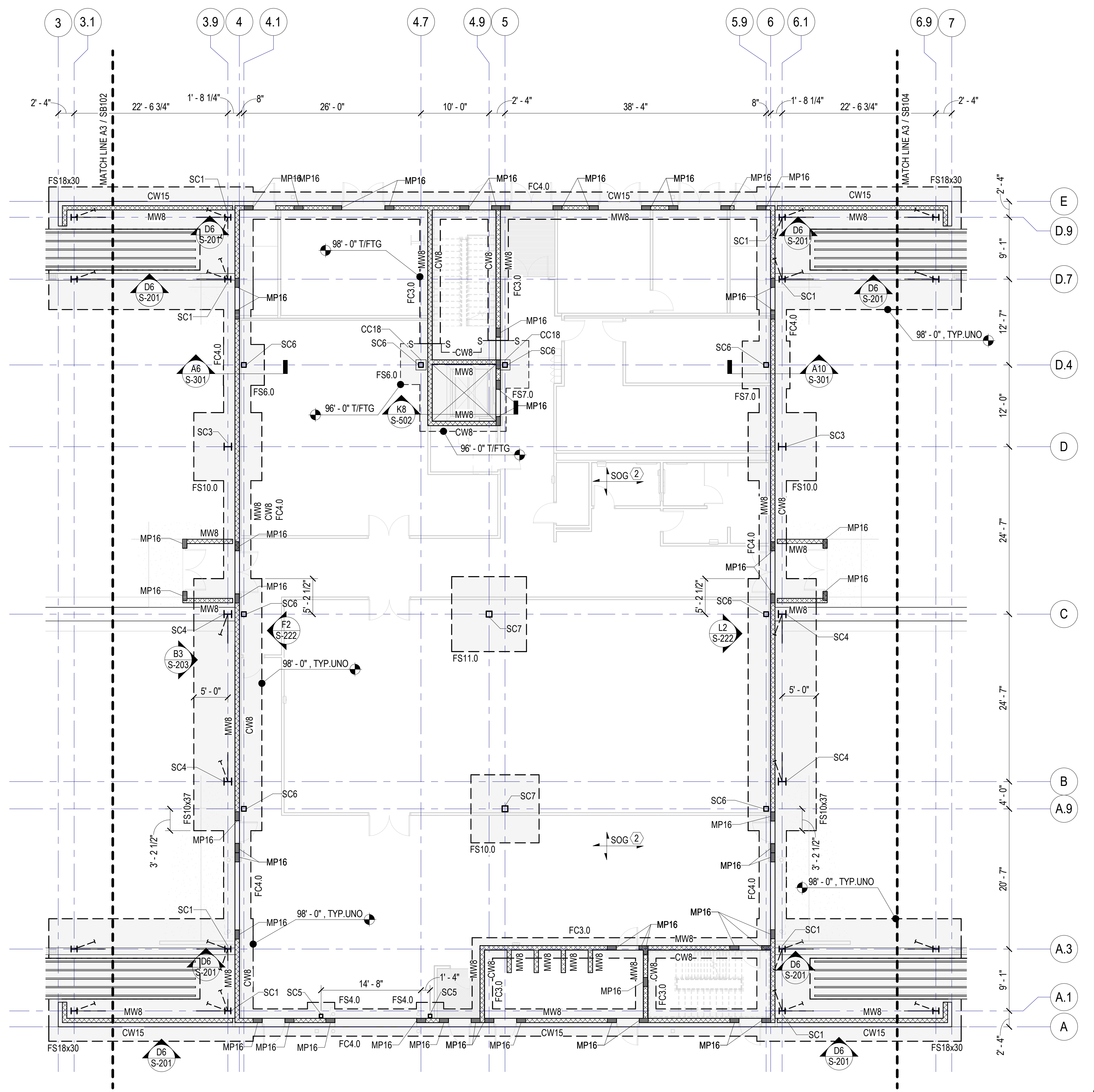

A3 FOUNDATION PLAN - AREA C
SCALE: 1/8" = 1'-0"

- ### GENERAL NOTES
1. SEE SHEETS S-001 TO S-005 FOR GENERAL NOTES AND DESIGN CRITERIA.
 2. SEE ARCHITECTURAL, CIVIL, AND LANDSCAPE DRAWINGS FOR EXTERIOR CONCRETE WORK AT DOORS, SIDEWALKS, ETC.
 3. TYPICAL TOP OF SLAB ELEVATION = RE: CIVIL AND ARCH. THIS IS THE DATUM 100'-0". ALL ELEVATIONS ARE REFERENCED FROM THIS ELEVATION.
 4. FOUNDATIONS ARE SPREAD, STRIP, MAT FOOTINGS. ALL FOOTINGS TO BE CENTERED BELOW WALLS AND COLUMNS (OR COLUMN GROUP) UNLESS NOTED OTHERWISE.
 5. ALL TOP OF FOOTING ELEVATIONS = 98'-0" UNLESS NOTED OTHERWISE.
 6. ALL EXTERIOR FOOTINGS MUST BEAR AT OR BELOW MINIMUM BEARING DEPTH AS SPECIFIED IN DESIGN CRITERIA SECTION. PROVIDE ADDITIONAL FOOTING STEPS AS REQUIRED. CONTRACTOR SHALL COORDINATE ALL FOOTING STEP LOCATIONS.
 7. RE: PLAN FOR SLAB ON GRADE THICKNESS AND REINFORCING.
 8. FOR DIMENSIONS NOT SHOWN ON THESE SHEETS, COORDINATE WALL OPENINGS, ELEVATIONS, SECTIONS, AND DETAILS WITH ARCHITECTURAL, MECHANICAL, ELECTRICAL, AND PLUMBING DRAWINGS.
 9. FOR UTILITIES PASSING BELOW FOOTINGS, SEE L17/S-501. CONTRACTOR MUST COORDINATE ALL UTILITY AND FOOTING STEP LOCATIONS. SEE L13/S-501 FOR TYPICAL FOOTING STEP DETAIL AND D9/S-501 FOR UTILITY PENETRATION THROUGH FOUNDATION WALLS.
 10. ALL FOOTINGS AT THE END OF A WALL THAT DOES NOT END IN A CORNER CONDITION SHALL EXTEND 1'-0" PAST WALL END.
 11. CMU WALLS ARE MW8 UNLESS NOTED OTHERWISE.
 12. CONCRETE STEM WALLS ARE CW8 UNDER MW8 CMU AND CW15 UNDER MW8 WALLS WITH CMU VENEER UNLESS NOTED OTHERWISE.
 13. RE: ARCH DRAWINGS FOR SLAB SLOPES AND DRAINS, ETC.

- ### KEYNOTES
- ① 12 1/2" THICK UNREINFORCED SLAB ON GRADE ON 15 MIL VAPOR RETARDER OVER 6" MIN OF CRUSHED STONE AGGREGATE AND 12" MIN COMPACTED NON-EXPANSIVE FILL (SEE GEOTECH REPORT). SLAB ON GROUND JOINTS MUST BE LOCATED NO GREATER THAN 20 FT ON CENTER EACH DIRECTION, RE: E6/S-502 AND E10/S-502.)
 - ② 6" THICK REINFORCED SLAB ON GRADE W/ #4 @ 18" OC EACH WAY ON 15 MIL VAPOR RETARDER OVER 6" MIN OF CRUSHED STONE AGGREGATE AND 12" MIN COMPACTED NON-EXPANSIVE FILL (SEE GEOTECH REPORT). SLAB ON GROUND JOINTS MUST BE LOCATED NO GREATER THAN 15 FT ON CENTER EACH DIRECTION, RE: E6/S-502 AND E10/S-502.)
 - ③ 8" THICK UNREINFORCED CONC. SLAB OVER CONC. MAT FOOTING AT HANGAR DOOR SUPPORT RAILS. RE: A12/S-502
 - ④ RE: H9/S-501 FOR SLAB REINFORCING AT OPENINGS AND RE-ENTRANT CORNERS, TYP

TRENCH DRAIN COORDINATION
AND DETAILS IN PROGRESS

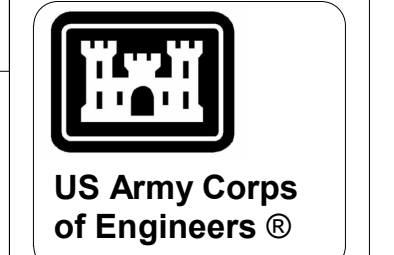
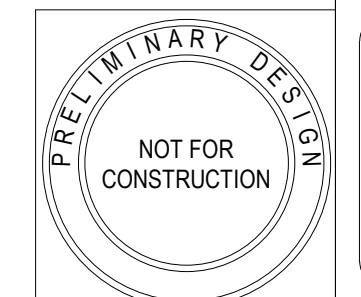
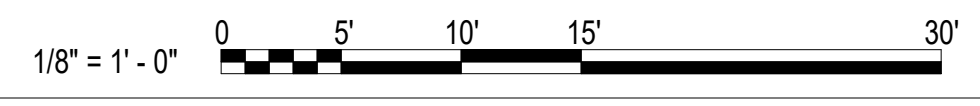
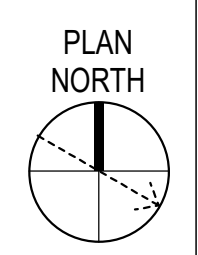
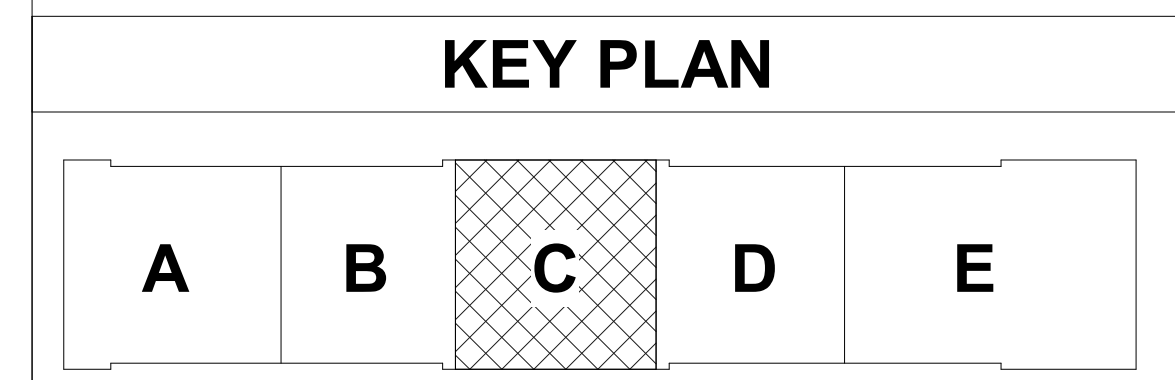

MARK	DESCRIPTION	DATE

ISSUE DATE: NOVEMBER 13, 2025	CONTRACT NO.: WB12PL25C0037
DESIGNED BY: A. VALENCIA	ISSUED BY: P. PASZCZUK
DRAWN BY: R. CARLSON	DATE:
CHECKED BY: D. CLAYSON	
SUBMITTED BY: P. PASZCZUK	

US ARMY CORPS OF ENGINEERS
LOS ANGELES DISTRICT

KORTE CONSTRUCTION
5700 OAKLAND AVE. SUITE 275
ST. LOUIS, MO 63110

CREECH AIR FORCE BASE, CLARK COUNTY, NV
DISASTER RESILIENCY PROGRAM (DRP) - PHASE 2
494137

FOUNDATION PLAN - AREA C

SHEET ID
SB103

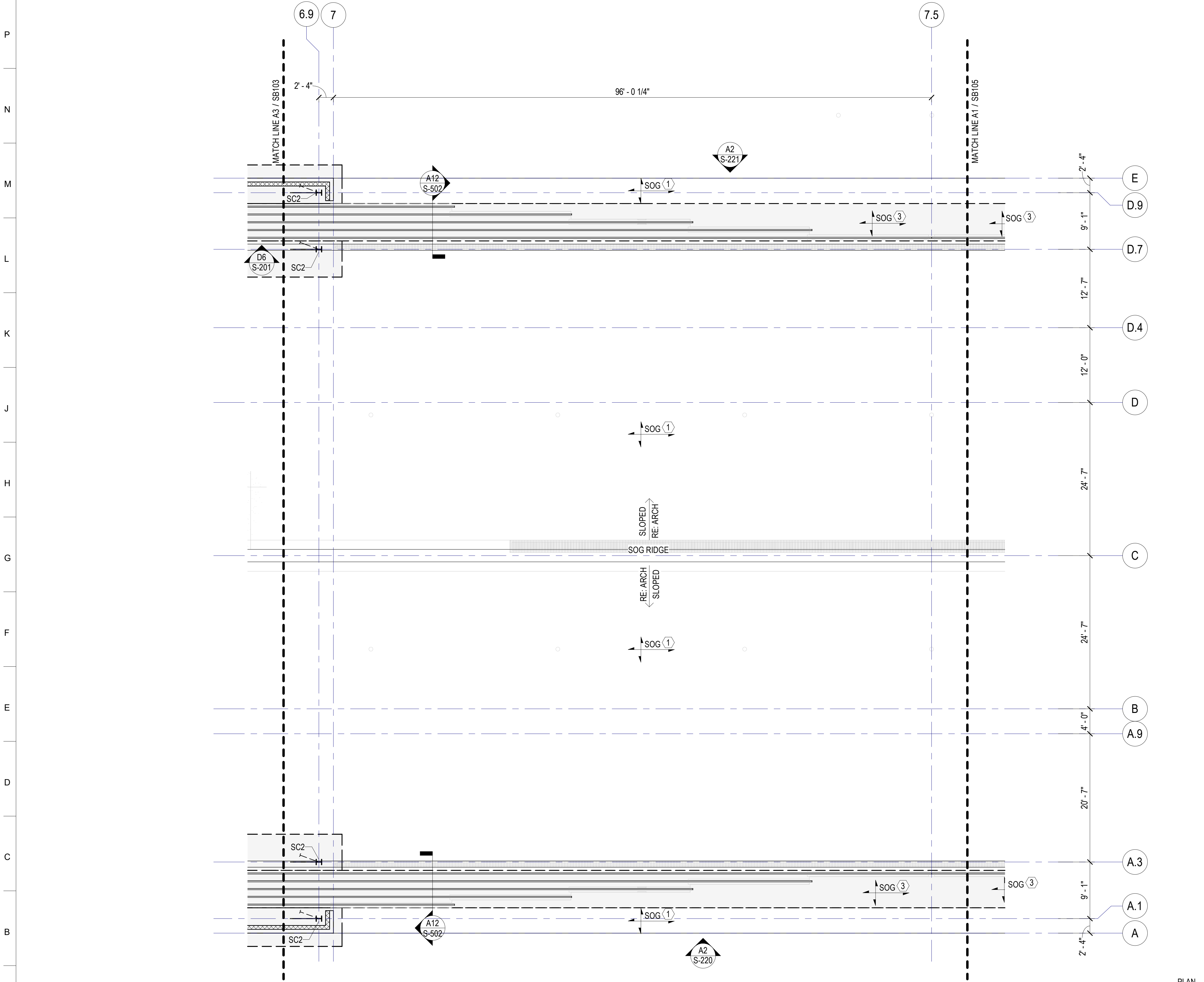

A3 FOUNDATION PLAN - AREA D
SCALE: 1/8" = 1'-0"

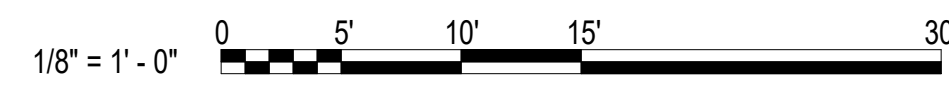

GENERAL NOTES

1. SEE SHEETS S-001 TO S-005 FOR GENERAL NOTES AND DESIGN CRITERIA.
2. SEE ARCHITECTURAL, CIVIL, AND LANDSCAPE DRAWINGS FOR EXTERIOR CONCRETE WORK AT DOORS, SIDEWALKS, ETC.
3. TYPICAL TOP OF SLAB ELEVATION = RE: CIVIL AND ARCH. THIS IS THE DATUM 100'-0". ALL ELEVATIONS ARE REFERENCED FROM THIS ELEVATION.
4. FOUNDATIONS ARE SPREAD, STRIP, MAT FOOTINGS. ALL FOOTINGS TO BE CENTERED BELOW WALLS AND COLUMNS (OR COLUMN GROUP) UNLESS NOTED OTHERWISE.
5. ALL TOP OF FOOTING ELEVATIONS = 98'-0" UNLESS NOTED OTHERWISE.
6. ALL EXTERIOR FOOTINGS MUST BEAR AT OR BELOW MINIMUM BEARING DEPTH AS SPECIFIED IN DESIGN CRITERIA SECTION. PROVIDE ADDITIONAL FOOTING STEPS AS REQUIRED. CONTRACTOR SHALL COORDINATE ALL FOOTING STEP LOCATIONS.
7. RE: PLAN FOR SLAB ON GRADE THICKNESS AND REINFORCING.
8. FOR DIMENSIONS NOT SHOWN ON THESE SHEETS, COORDINATE WALL OPENINGS, ELEVATIONS, SECTIONS, AND DETAILS WITH ARCHITECTURAL, MECHANICAL, ELECTRICAL, AND PLUMBING DRAWINGS.
9. FOR UTILITIES PASSING BELOW FOOTINGS, SEE L17/S-501. CONTRACTOR MUST COORDINATE ALL UTILITY AND FOOTING STEP LOCATIONS. SEE L13/S-501 FOR TYPICAL FOOTING STEP DETAIL AND D9/S-501 FOR UTILITY PENETRATION THROUGH FOUNDATION WALLS.
10. ALL FOOTINGS AT THE END OF A WALL THAT DOES NOT END IN A CORNER CONDITION SHALL EXTEND 1'-0" PAST WALL END.
11. CMU WALLS ARE MW8 UNLESS NOTED OTHERWISE.
12. CONCRETE STEM WALLS ARE CW8 UNDER MW8 CMU AND CW15 UNDER MW8 WALLS WITH CMU VENEER UNLESS NOTED OTHERWISE.
13. RE: ARCH DRAWINGS FOR SLAB SLOPES AND DRAINS, ETC.

KEYNOTES

- ① 12 1/2" THICK UNREINFORCED SLAB ON GRADE ON 15 MIL VAPOR RETARDER OVER 6" MIN OF CRUSHED STONE AGGREGATE AND 12" MIN COMPACTED NON-EXPANSIVE FILL (SEE GEOTECH REPORT). SLAB ON GROUND JOINTS MUST BE LOCATED NO GREATER THAN 20 FT ON CENTER EACH DIRECTION, RE: E6/S-502 AND E10/S-502.)
- ② 6" THICK REINFORCED SLAB ON GRADE W/ # 4 @ 18" OC EACH WAY ON 15 MIL VAPOR RETARDER OVER 6" MIN OF CRUSHED STONE AGGREGATE AND 12" MIN COMPACTED NON-EXPANSIVE FILL (SEE GEOTECH REPORT). SLAB ON GROUND JOINTS MUST BE LOCATED NO GREATER THAN 15 FT ON CENTER EACH DIRECTION, RE: E6/S-502 AND E10/S-502.)
- ③ 8" THICK UNREINFORCED CONC. SLAB OVER CONC. MAT FOOTING AT HANGAR DOOR SUPPORT RAILS. RE: A12/S-502
- ④ RE: H9/S-501 FOR SLAB REINFORCING AT OPENINGS AND RE-ENTRANT CORNERS, TYP

**TRENCH DRAIN COORDINATION
AND DETAILS IN PROGRESS**

KEY PLAN

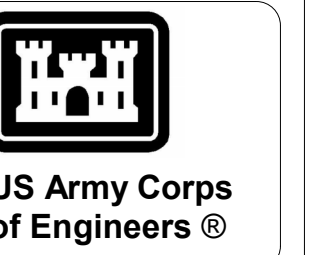
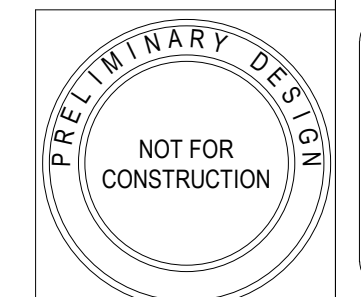
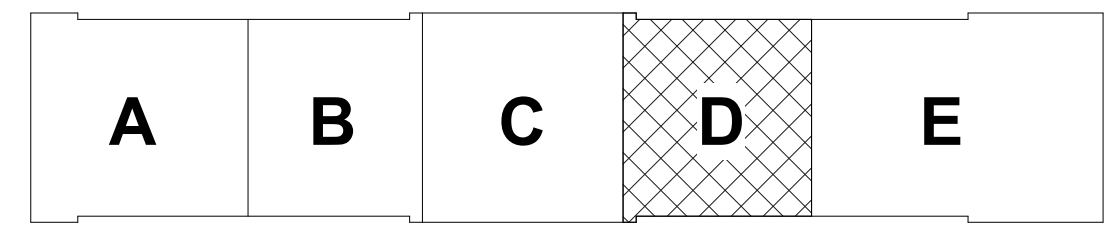

MARK	DESCRIPTION	DATE

DESIGNED BY: A. VALENCIA	ISSUE DATE: NOVEMBER 13, 2025
DRAWN BY: R. CARLSON	SOLICITATION NO.: W812PL25RA0012
CHECKED BY: D. CLAYSON	CONTRACT NO.: W812PL25C0037
SUBMITTED BY: P. PASZCZUK	SIZE: ANSI D

US ARMY CORPS OF ENGINEERS
LOS ANGELES DISTRICT

KORTE CONSTRUCTION
5700 OAKLAND AVE. SUITE 275
ST. LOUIS, MO 63110

CREECH AIR FORCE BASE, CLARK COUNTY, NV
DISASTER RESILIENCY PROGRAM (DRP) - PHASE 2
494137

FOUNDATION PLAN - AREA D

SHEET ID
SB104

DP-1 95% SUBMISSION

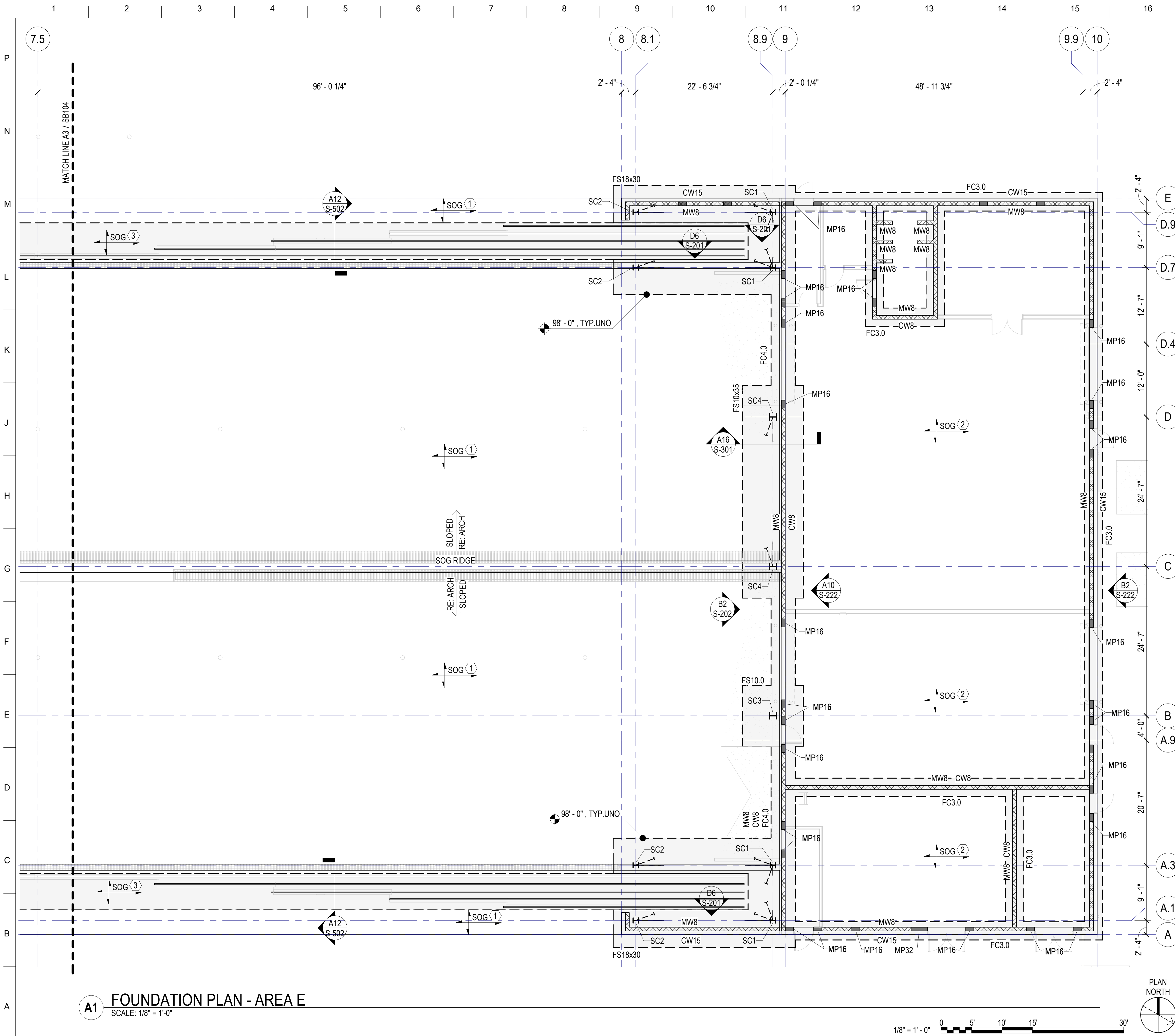

GENERAL NOTES

1. CONTRACTOR IS RESPONSIBLE FOR THE CONSTRUCTION SEQUENCE FOR ALL STRUCTURAL ELEMENTS IN THE PROJECT. CONTRACTOR IS RESPONSIBLE TO PROVIDE ANY SHORING OR BRACING AS NEEDED UNTIL STRUCTURE IS COMPLETE.
2. ALL BEAM-TO-COLUMN CONNECTIONS SHALL BE SINGLE SHEAR TAB CONNECTIONS UNLESS NOTED OTHERWISE. SEE TYPICAL STEEL-TO-STEEL CONNECTION SCHEDULE.
3. CONTRACTOR TO COORDINATE ALL ROOF EDGES AND OPENINGS. OPENINGS LESS THAN 6" IN ALL DIRECTIONS ARE NOT SHOWN IN STRUCTURAL DRAWINGS. RE: L1-L17/S-511 FOR PLACEMENT CRITERIA.
4. RE: SHEETS S-001 - S-005 FOR GENERAL NOTES AND DESIGN CRITERIA.
5. RE: SHEETS S-511 - S-513 FOR TYPICAL ROOF FRAMING DETAILS.
6. RE: SHEETS S-601 - S-602 FOR SCHEDULES.

KEYNOTES

- ① 12 1/2" THICK UNREINFORCED SLAB ON GRADE ON 15 MIL VAPOR RETARDER OVER 6" MIN OF CRUSHED STONE AGGREGATE AND 12" MIN COMPACTED NON-EXPANSIVE FILL (SEE GEOTECH REPORT). SLAB ON GROUND JOINTS MUST BE LOCATED NO GREATER THAN 20 FT ON CENTER EACH DIRECTION. RE: E6/S-502 AND E10/S-502.)
- ② 6" THICK REINFORCED SLAB ON GRADE W/ # 4 @ 18" OC EACH WAY ON 15 MIL VAPOR RETARDER OVER 6" MIN OF CRUSHED STONE AGGREGATE AND 12" MIN COMPACTED NON-EXPANSIVE FILL (SEE GEOTECH REPORT). SLAB ON GROUND JOINTS MUST BE LOCATED NO GREATER THAN 15 FT ON CENTER EACH DIRECTION. RE: E6/S-502 AND E10/S-502.)
- ③ 8" THICK UNREINFORCED CONC. SLAB OVER CONC. MAT FOOTING AT HANGAR DOOR SUPPORT RAILS. RE: A12/S-502
- ④ RE: H9/S-501 FOR SLAB REINFORCING AT OPENINGS AND RE-ENTRANT CORNERS, TYP

TRENCH DRAIN COORDINATION AND DETAILS IN PROGRESS

KEY PLAN

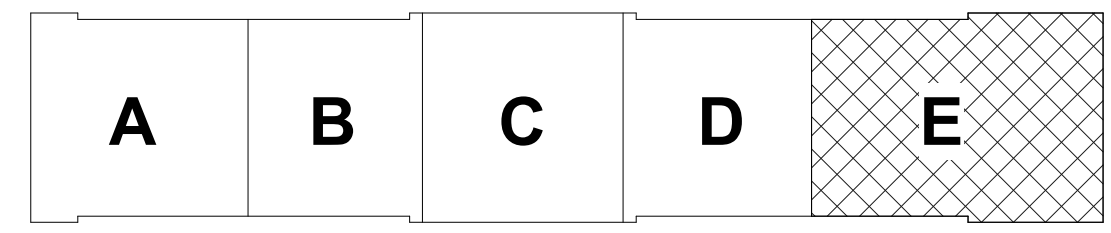

A1 FOUNDATION PLAN - AREA E
SCALE: 1/8" = 1'-0"

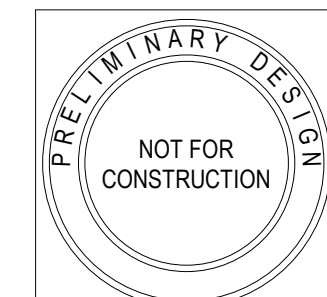



US Army Corps of Engineers
of Engineers®

MARK	DESCRIPTION	DATE

DESIGNED BY: A. VALENCIA	ISSUE DATE: NOVEMBER 13, 2025	DRAWN BY: R. CARLSON	SOLICITATION NO.: W812PL25RA0012
CHECKED BY: D. CLAYSON	CONTRACT NO.:	SUBMITTED BY: P. PASZCZUK	CONTRACT NO.:
US ARMY CORPS OF ENGINEERS LOS ANGELES DISTRICT KORTE CONSTRUCTION 5700 OAKLAND AVE. SUITE 275 ST. LOUIS, MO 63110			

CREECH AIR FORCE BASE, CLARK COUNTY, NV DISASTER RESILIENCY PROGRAM (DRP) - PHASE 2 494137	FOUNDATION PLAN - AREA E
--	--------------------------

SHEET ID	DATE
SB105	

DP-1 95% SUBMISSION

1 2 3 4 5 6 7 8 9 10 11 12 13 14 15 16 17 18 19 20

P
N
M
L
K
J
H
G
F
E
D
C
B
A

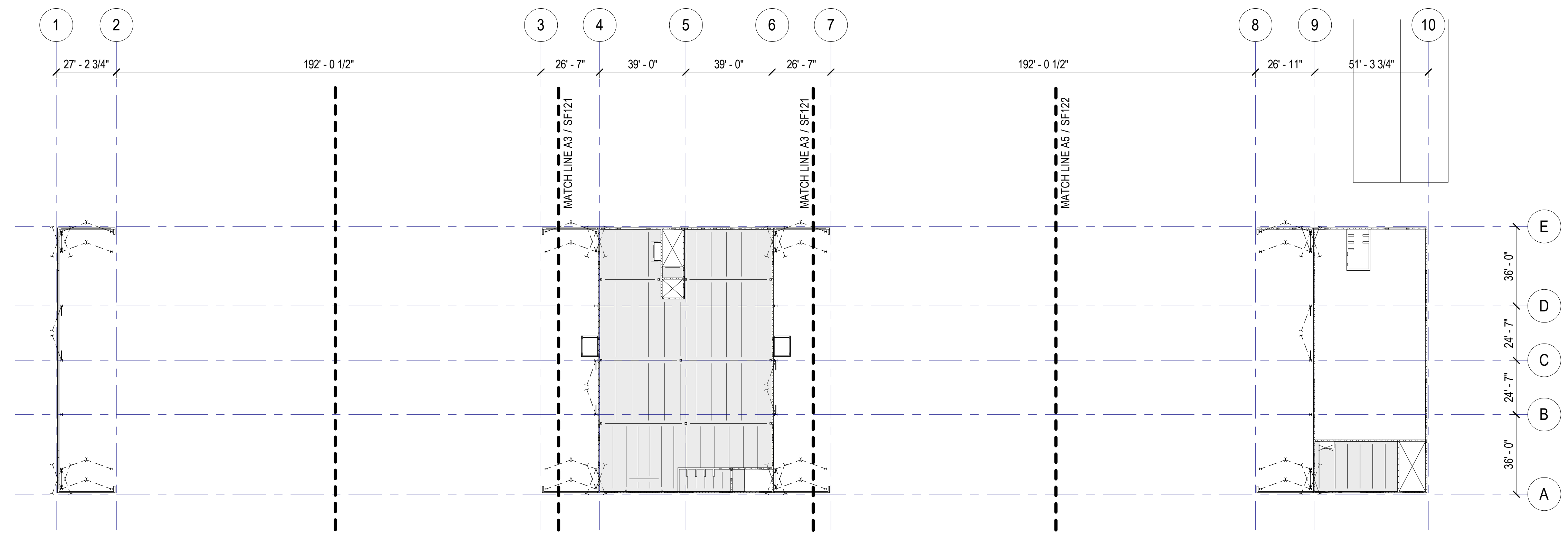

D1 OVERALL SECOND AND MEZZANINE FLOOR FRAMING PLAN
1" = 30'-0"

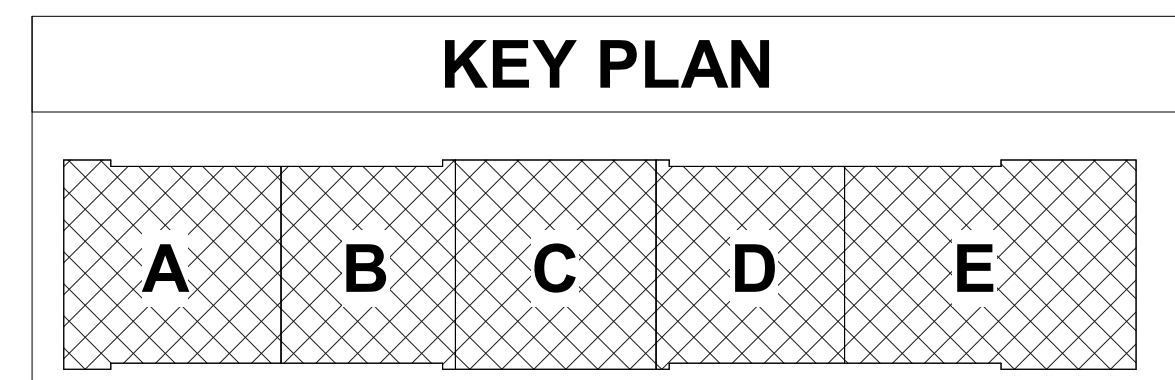

1" = 30' - 0"
0 15' 30' 60' 90'

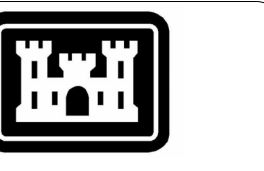
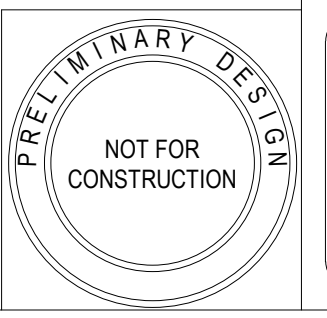
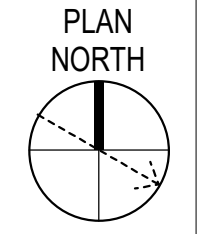

US Army Corps of Engineers®

MARK	DESCRIPTION	DATE

DESIGNED BY: A. VALENCIA	ISSUE DATE: NOVEMBER 13, 2025
DRAWN BY: R. CARLSON	SOLICITATION NO.:
CHECKED BY: D. CLAYSON	W812P25RA0012
SUBMITTED BY: P. PASZCZUK	CONTRACT NO.:
SIZE: ANSI D	W812P25C0037

US ARMY CORPS OF ENGINEERS
LOS ANGELES DISTRICT
KORTE CONSTRUCTION
5700 OAKLAND AVE. SUITE 275
ST. LOUIS, MO 63110

CREECH AIR FORCE BASE, CLARK COUNTY, NV
DISASTER RESILIENCY PROGRAM (DRP) - PHASE 2
494137
OVERALL SECOND AND MEZZANINE FLOOR
FRAMING PLAN

SHEET ID
SF120

DP-1 95% SUBMISSION

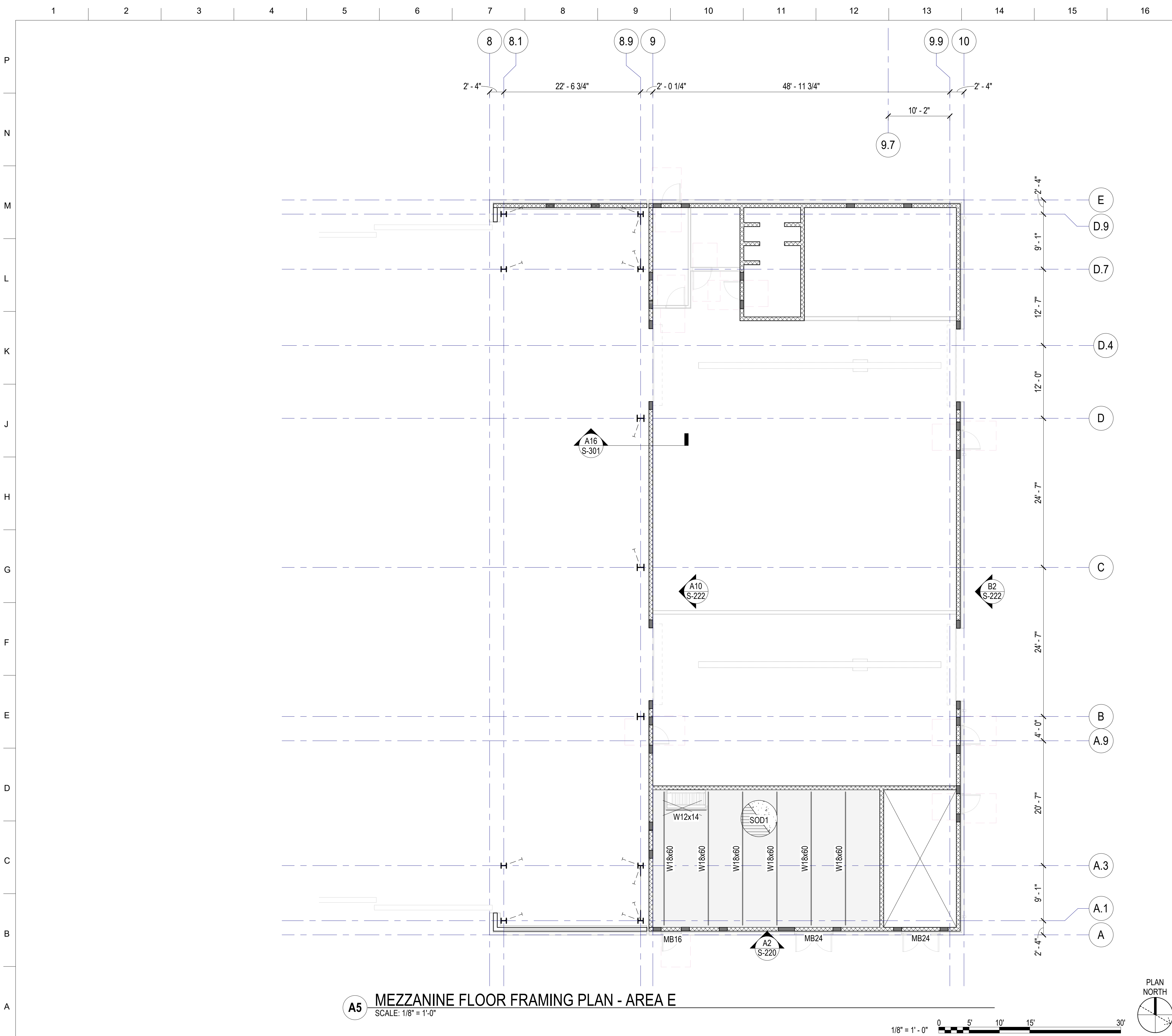

A5 MEZZANINE FLOOR FRAMING PLAN - AREA E
SCALE: 1/8" = 1'-0"

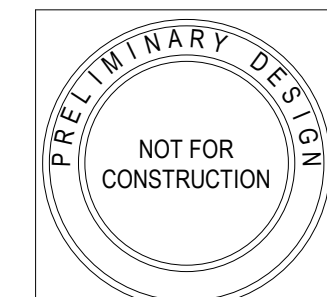

ROOF FRAMING NOTES

1. CONTRACTOR IS RESPONSIBLE FOR THE CONSTRUCTION SEQUENCE FOR ALL STRUCTURAL ELEMENTS IN THE PROJECT. CONTRACTOR IS RESPONSIBLE TO PROVIDE ANY SHORING OR BRACING AS NEEDED UNTIL STRUCTURE IS COMPLETE.
2. ALL BEAM-TO-COLUMN CONNECTIONS SHALL BE SINGLE SHEAR TAB CONNECTIONS UNLESS NOTED OTHERWISE. SEE TYPICAL STEEL-TO-STEEL CONNECTION SCHEDULE.
3. SHOP DRAWINGS MUST BE PRODUCED FOR ALL JOISTS AND SHALL BE SUBMITTED TO THE ENGINEER FOR APPROVAL PRIOR TO FABRICATION. CALCULATIONS SHALL BE SUBMITTED WITH THE SHOP DRAWINGS AND SHALL BEAR THE STAMP OF A LICENSED ENGINEER.
4. OPEN WEB STEEL JOISTS SHALL BE DESIGNED BY THE MANUFACTURER TO SUPPORT THE MECHANICAL, AXIAL (WL/EQ), LATERAL, POINT, AND UNIFORM LOADS SHOWN ON PLANS AND IN DETAILS. LOADS SHOWN ARE ASD MAGNITUDE LOADS UNLESS NOTED OTHERWISE.
5. THE STEEL JOIST SUPPLIER IS RESPONSIBLE IN DESIGNING ALL JOISTS, INCLUDING SLOPE, CAMBER, BEARING ENDS, ETC. ALL DESIGNS SHALL BE IN ACCORDANCE WITH SJI SPECIFICATIONS WITH A MAXIMUM DEFLECTION OF JOISTS OF TL/180 AND LL/240.
6. HORIZONTAL AND CROSS BRIDGING SHALL BE SIZED, LOCATED, AND SUPPLIED BY THE JOIST MANUFACTURER.
7. ALL STABILIZER PLATES SHALL BE 6"x6" x CHORD GAP-1/4" WITH A 3/4" DIAMETER HOLE, AND MUST EXTEND 3" MINIMUM BELOW THE BOTTOM CHORD.
8. ALL CONCENTRATED LOADS GREATER THAN 100 POUNDS SUPPORTED BY OPEN WEB JOISTS SHALL BE LOCATED WITHIN 6" OF PANEL POINT. OTHERWISE, JOIST SHALL BE REINFORCED WITH AN ADDITIONAL WEB MEMBER. (RE: H1/S-511)
9. BOTTOM CHORD OF ANY JOIST SHALL NOT BE USED TO BRACE ANY MISC EQUIPMENT.
10. JOIST BRIDGING SHALL NEVER BE USED TO SUPPORT HANGING LOADS.
11. JOIST LOADS SHOWN ON PLAN WITH THE JOIST DESIGNATION "K (XX/XX)" ACCOUNTS FOR TOTAL LOAD/LIVE LOAD (ASD).
12. OPEN WEB STEEL JOISTS SHALL BE DESIGNED FOR A NET UPLIFT DUE TO WIND LOADING, RE: SHEET S-005.
13. STEEL JOISTS SHALL BE DESIGNED FOR AN ADDITIONAL VERT LIVE LOAD (ASD) OF +/-500# AT EACH PANEL POINT
14. STANDARD JOIST SEAT DEPTH SHALL BE 2 1/2". CONTRACTOR TO COORDINATE TOP OF GIRDERS USING 2 1/2" JOIST SEAT DEPTH UNO.
15. CONTRACTOR TO COORDINATE ALL ROOF EDGES AND OPENINGS. OPENINGS LESS THAN 6" IN ALL DIRECTIONS ARE NOT SHOWN IN STRUCTURAL DRAWINGS. RE: L1-L17/S-511 FOR PLACEMENT CRITERIA.
16. RE: SHEETS S-001 - S-005 FOR GENERAL NOTES AND DESIGN CRITERIA.
17. RE: SHEETS S-511 - S-513 FOR TYPICAL ROOF FRAMING DETAILS.
18. RE: SHEETS S-601 - S-602 FOR SCHEDULES.

KEYNOTES

- ① HANGING FAN ON BOTTOM CHORD OF TRUSS ON GRID D. APPROXIMATE WEIGHT OF 300LBS (DL ASD). RE: ARCH/MEP FOR EXACT LOCATION. RE: MFR FOR ATTACHMENT
- ② PROVIDE L4x4x1/4 BRACING AT THIRD POINTS OF BEAM
- ③ PROVIDE L8x8x1/2 BRACING AT THIRD POINTS OF BEAM
- ④ PROVIDE L8x8x1/2 BRACING AT BEAM HALF POINT
- ⑤ SUPPORT FRAMING FOR 1-TON MONORAIL HOIST CRANE

CRANE COORDINATION AND LATERAL BRACING IN PROGRESS

KEY PLAN

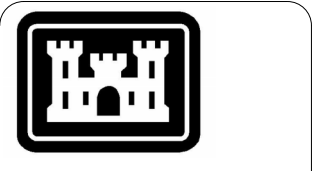
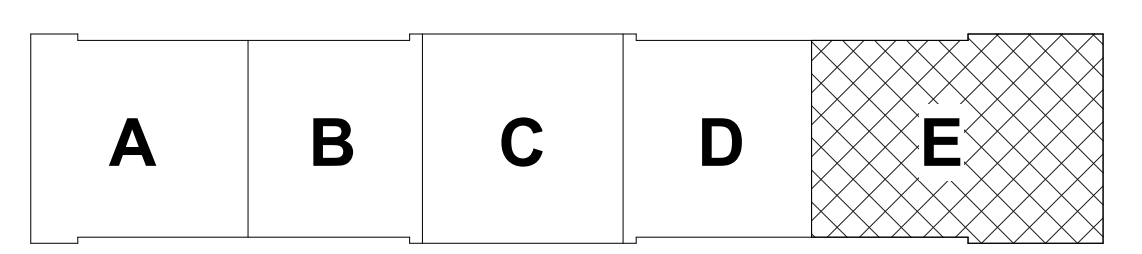

US Army Corps of Engineers®

MARK	DESCRIPTION	DATE

DESIGNED BY: A. VALENCIA	ISSUE DATE: NOVEMBER 13, 2025
DRAWN BY: R. CARLSON	SOLICITATION NO.: WB12PL259RA0012
CHECKED BY: D. CLAYSON	CONTRACT NO.: WB12PL25C0037
SUBMITTED BY: P. PASZCZUK	SIZE: ANSI D

US ARMY CORPS OF ENGINEERS
LOS ANGELES DISTRICT

KORTE CONSTRUCTION
5700 OAKLAND AVE, SUITE 275
ST. LOUIS, MO 63110

CREECH AIR FORCE BASE, CLARK COUNTY, NV
DISASTER RESILIENCY PROGRAM (DRP) - PHASE 2
494137
MEZZANINE FLOOR FRAMING PLAN - AREA E

SHEET ID
SF122

DP-1 95% SUBMISSION

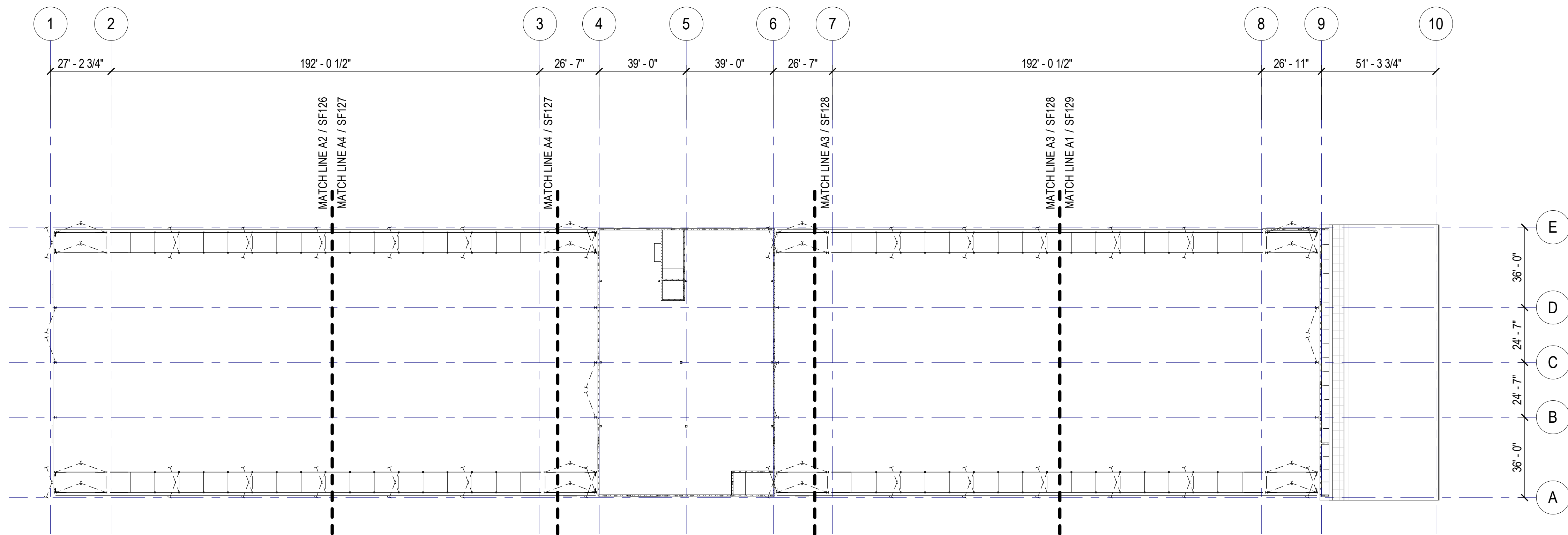

1 OVERALL HANGAR DOOR FRAMING PLAN
1" = 30'-0" REF: S-201

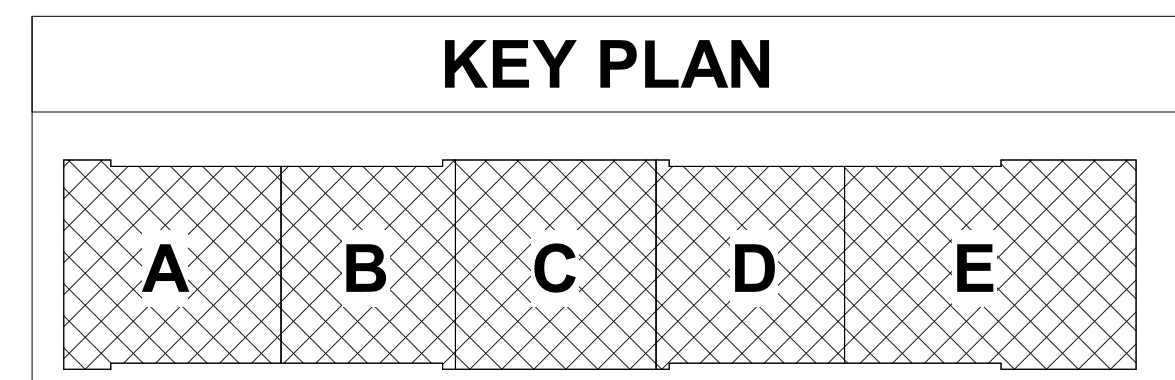

1" = 30'-0" 0 15' 30' 60' 90'

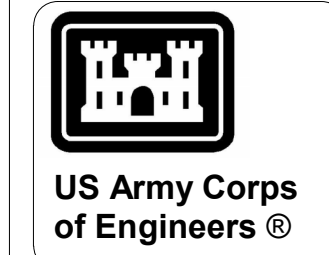
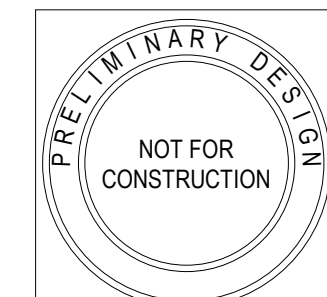
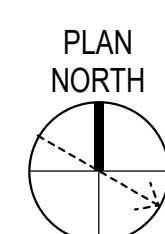

MARK	DESCRIPTION	DATE

DESIGNED BY: A. VALENCIA DRAWN BY: R. CARLSON CHECKED BY: D. CLAYSON SUBMITTED BY: P. PASZCZUK SIZE: ANSI D	ISSUE DATE: NOVEMBER 13, 2025 SOLICITATION NO.: W812PL25RA0012 CONTRACT NO.: W812PL25C0037
US ARMY CORPS OF ENGINEERS LOS ANGELES DISTRICT	KORTE CONSTRUCTION 5700 OAKLAND AVE. SUITE 275 ST. LOUIS, MO 63110

CREECH AIR FORCE BASE, CLARK COUNTY, NV
DISASTER RESILIENCY PROGRAM (DRP) - PHASE 2
494137
OVERALL HANGAR DOOR FRAMING PLAN

SHEET ID
SF125

1 2 3 4 5 6 7 8 9 10 11 12 13 14 15 16 17 18 19 20

P
N
M
L
K
J
H
G
F
E
D
C
B
A

1 1.1 1.9 2

2.5

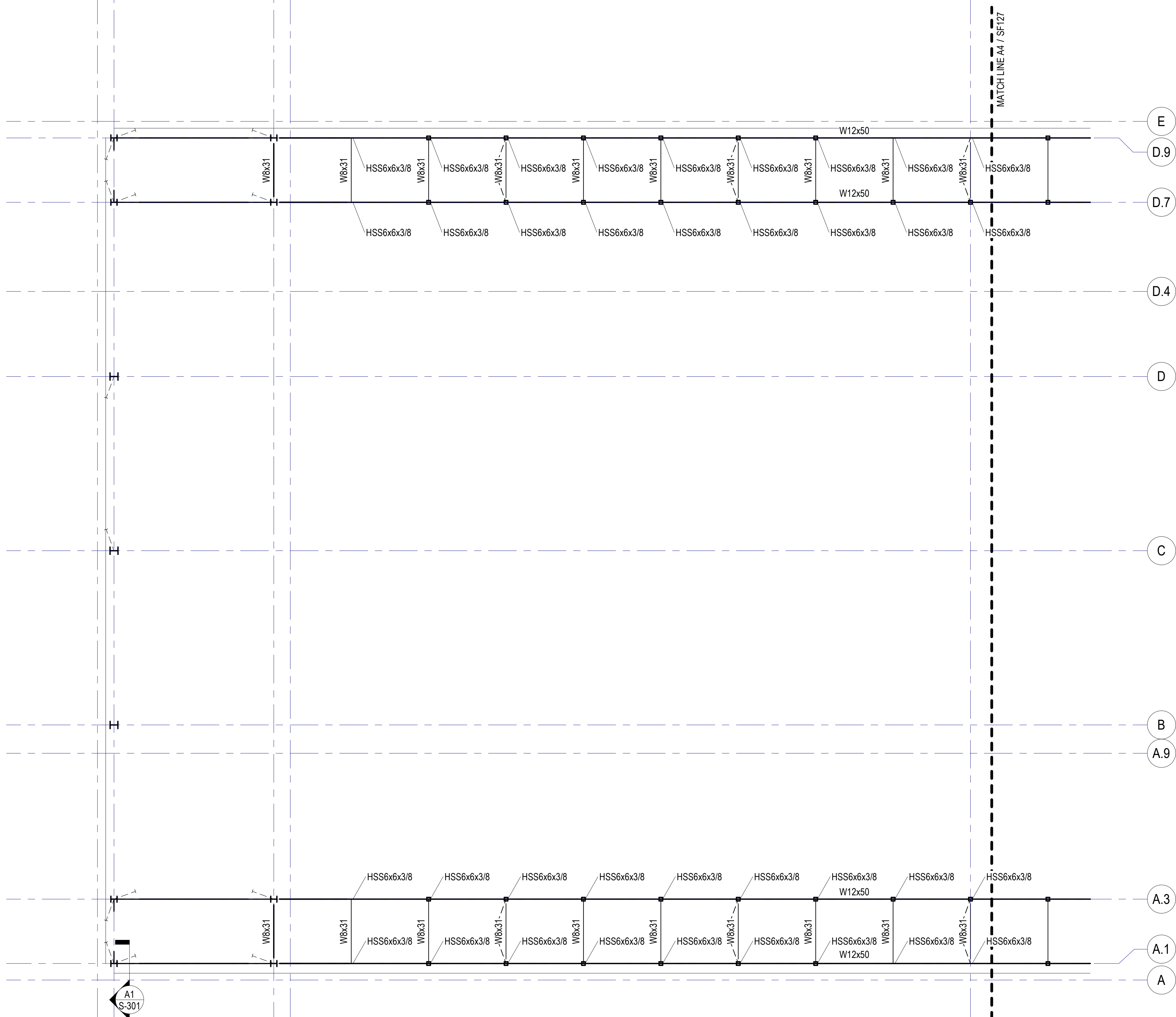

A2 HANGAR DOOR FRAMING PLAN - AREA A
1/8" = 1'-0" REF: S-201

1/8" = 1'-0" 0 5' 10' 15' 30'

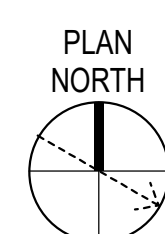

FRAMING NOTES

1. CONTRACTOR IS RESPONSIBLE FOR THE CONSTRUCTION SEQUENCE FOR ALL STRUCTURAL ELEMENTS IN THE PROJECT. CONTRACTOR IS RESPONSIBLE TO PROVIDE ANY SHORING OR BRACING AS NEEDED UNTIL STRUCTURE IS COMPLETE.
2. ALL BEAM-TO-COLUMN CONNECTIONS SHALL BE SINGLE SHEAR TAB CONNECTIONS UNLESS NOTED OTHERWISE. SEE TYPICAL STEEL-TO-STEEL CONNECTION SCHEDULE.
3. CONTRACTOR TO COORDINATE ALL ROOF EDGES AND OPENINGS. OPENINGS LESS THAN 6" IN ALL DIRECTIONS ARE NOT SHOWN IN STRUCTURAL DRAWINGS. RE: L1-L17/S-511 FOR PLACEMENT CRITERIA.
4. RE: SHEETS S-001 - S-005 FOR GENERAL NOTES AND DESIGN CRITERIA.
5. RE: SHEETS S-511 - S-513 FOR TYPICAL ROOF FRAMING DETAILS.
6. RE: SHEETS S-601 - S-602 FOR SCHEDULES.



US Army Corps of Engineers®

MARK	DESCRIPTION	DATE

DESIGNED BY: A. VALENCIA	ISSUE DATE: NOVEMBER 13, 2025
DRAWN BY: R. CARLSON	SOLICITATION NO.: WB12PL25RA0012
CHECKED BY: D. CLAYSON	CONTRACT NO.: WB12PL25C0037
SUBMITTED BY: P. PASZCZUK	SIZE: ANSI D
US ARMY CORPS OF ENGINEERS LOS ANGELES DISTRICT	
KORTE CONSTRUCTION 5700 OAKLAND AVE. SUITE 275 ST. LOUIS, MO 63110	

KEY PLAN

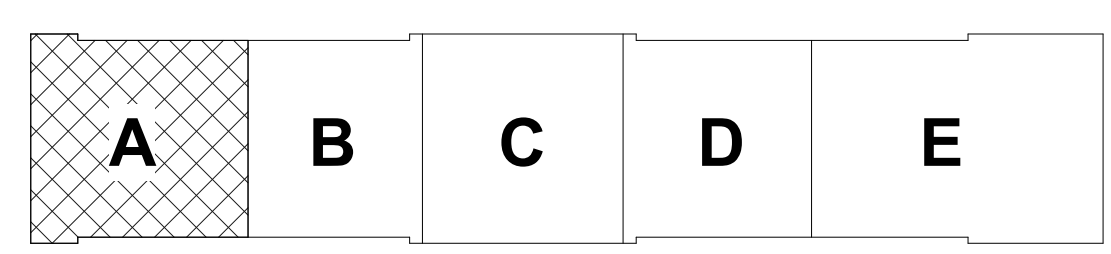

CREECH AIR FORCE BASE, CLARK COUNTY, NV
DISASTER RESILIENCY PROGRAM (DRP) - PHASE 2
494137
HANGAR DOOR FRAMING PLAN - AREA A

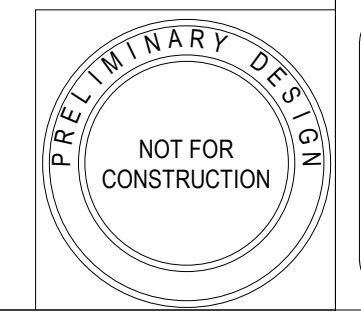

SHEET ID
SF126

DP-1 95% SUBMISSION

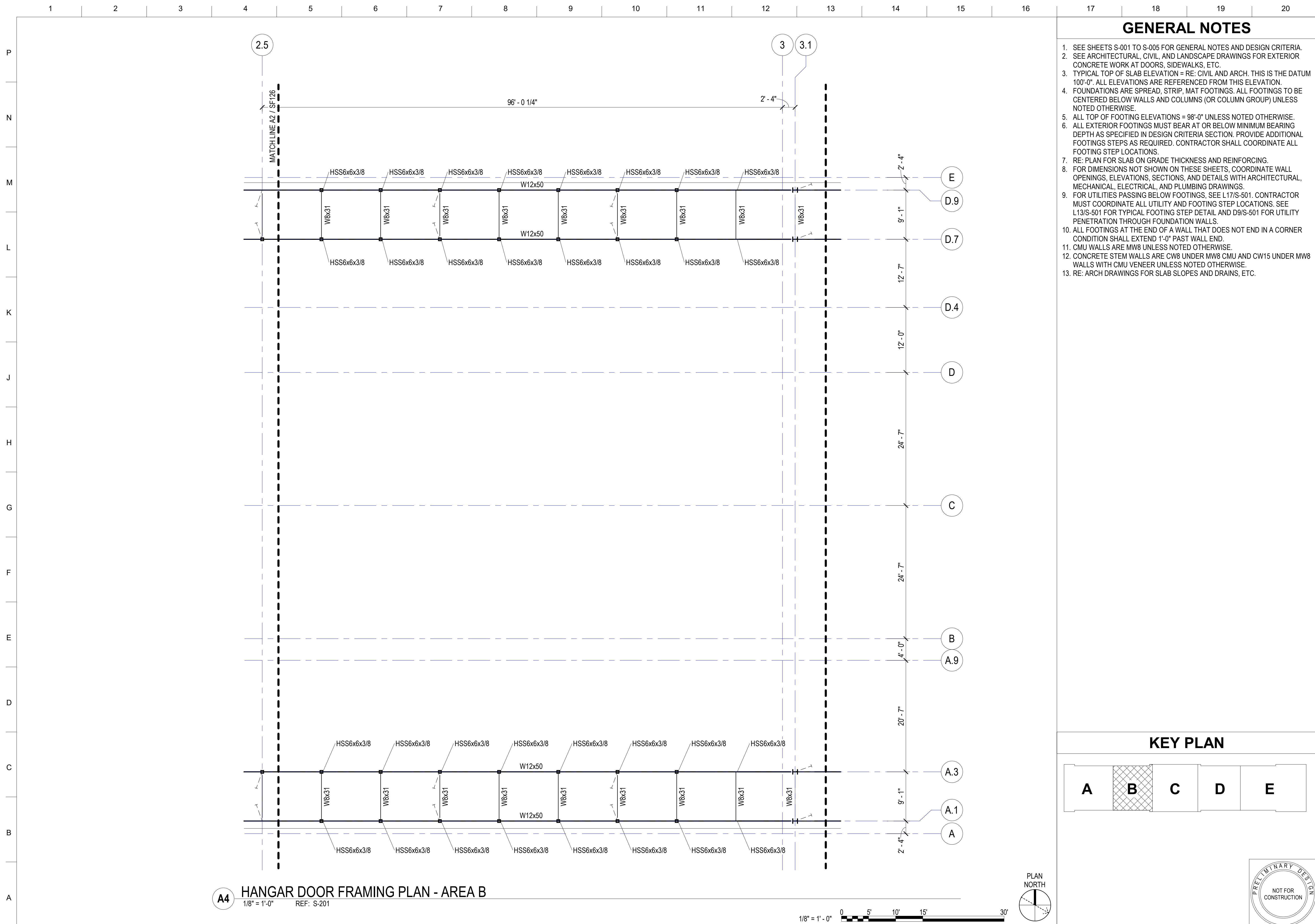

A4 HANGAR DOOR FRAMING PLAN - AREA B
1/8" = 1'-0" REF: S-201

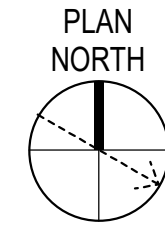

GENERAL NOTES

- SEE SHEETS S-001 TO S-005 FOR GENERAL NOTES AND DESIGN CRITERIA.
- SEE ARCHITECTURAL, CIVIL, AND LANDSCAPE DRAWINGS FOR EXTERIOR CONCRETE WORK AT DOORS, SIDEWALKS, ETC.
- TYPICAL TOP OF SLAB ELEVATION = RE: CIVIL AND ARCH. THIS IS THE DATUM 100'-0". ALL ELEVATIONS ARE REFERENCED FROM THIS ELEVATION.
- FOUNDATIONS ARE SPREAD, STRIP, MAT FOOTINGS. ALL FOOTINGS TO BE CENTERED BELOW WALLS AND COLUMNS (OR COLUMN GROUP) UNLESS NOTED OTHERWISE.
- ALL TOP OF FOOTING ELEVATIONS = 98'-0" UNLESS NOTED OTHERWISE.
- ALL EXTERIOR FOOTINGS MUST BEAR AT OR BELOW MINIMUM BEARING DEPTH AS SPECIFIED IN DESIGN CRITERIA SECTION. PROVIDE ADDITIONAL FOOTING STEPS AS REQUIRED. CONTRACTOR SHALL COORDINATE ALL FOOTING STEP LOCATIONS.
- RE: PLAN FOR SLAB ON GRADE THICKNESS AND REINFORCING.
- FOR DIMENSIONS NOT SHOWN ON THESE SHEETS, COORDINATE WALL OPENINGS, ELEVATIONS, SECTIONS, AND DETAILS WITH ARCHITECTURAL, MECHANICAL, ELECTRICAL, AND PLUMBING DRAWINGS.
- FOR UTILITIES PASSING BELOW FOOTINGS, SEE L17/S-501. CONTRACTOR MUST COORDINATE ALL UTILITY AND FOOTING STEP LOCATIONS. SEE L13/S-501 FOR TYPICAL FOOTING STEP DETAIL AND D9/S-501 FOR UTILITY PENETRATION THROUGH FOUNDATION WALLS.
- ALL FOOTINGS AT THE END OF A WALL THAT DOES NOT END IN A CORNER CONDITION SHALL EXTEND 1'-0" PAST WALL END.
- CMU WALLS ARE MW8 UNLESS NOTED OTHERWISE.
- CONCRETE STEM WALLS ARE CW8 UNDER MW8 CMU AND CW15 UNDER MW8 WALLS WITH CMU VENEER UNLESS NOTED OTHERWISE.
- RE: ARCH DRAWINGS FOR SLAB SLOPES AND DRAINS, ETC.

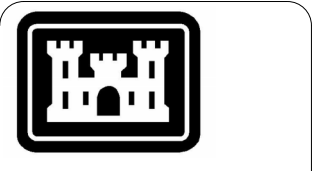

US Army Corps of Engineers®

MARK	DESCRIPTION	DATE

DESIGNED BY: A. VALENCIA	ISSUE DATE: NOVEMBER 13, 2025
DRAWN BY: R. CARLSON	SOLICITATION NO.: W812PL25RA0012
CHECKED BY: D. CLAYSON	CONTRACT NO.: W812PL25C0037
SUBMITTED BY: P. PASZCZUK	SIZE: ANSI D

US ARMY CORPS OF ENGINEERS
LOS ANGELES DISTRICT

KORTE CONSTRUCTION
5700 OAKLAND AVE. SUITE 275
ST. LOUIS, MO 63110

CREECH AIR FORCE BASE, CLARK COUNTY, NV
DISASTER RESILIENCY PROGRAM (DRP) - PHASE 2
494137
HANGAR DOOR FRAMING PLAN - AREA B

SHEET ID
SF127

KEY PLAN

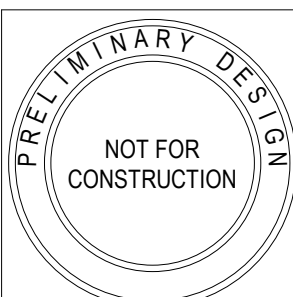
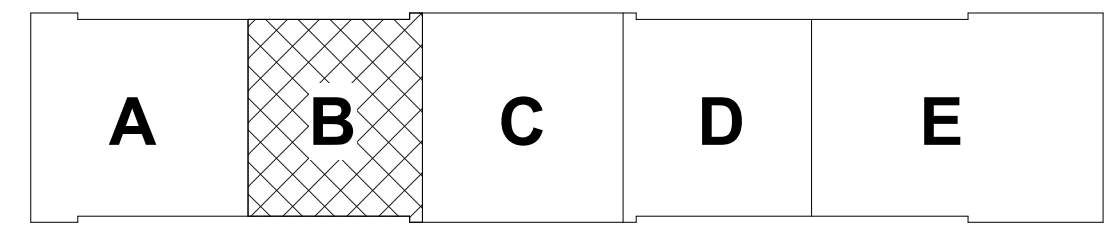

DP-1 95% SUBMISSION

P
N
M
L
K
J
H
G
F
E
D
C
B
A

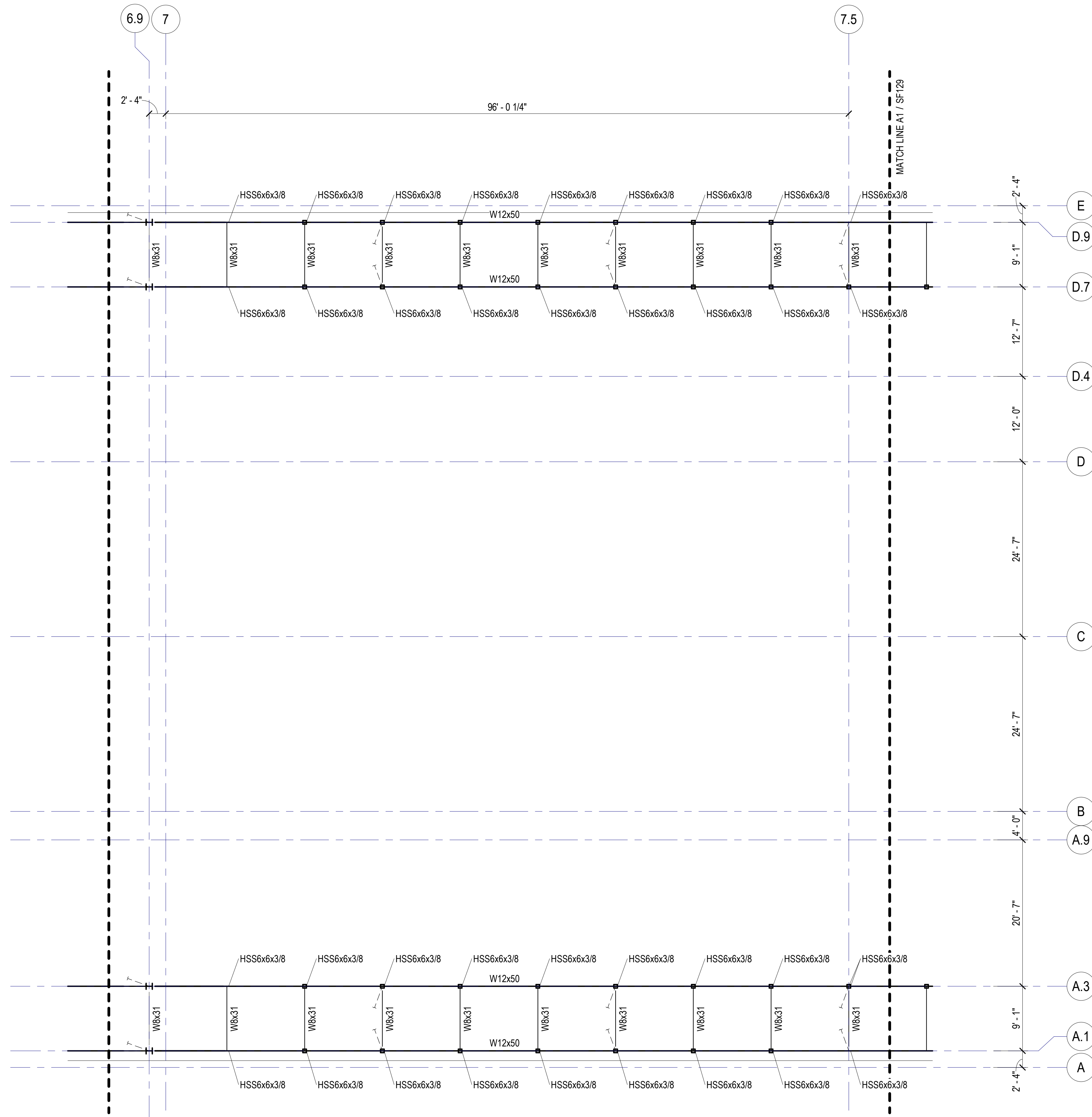

A3 HANGAR DOOR FRAMING PLAN - AREA D
1/8" = 1'-0" REF: S-201

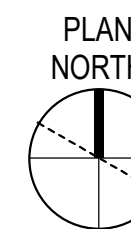
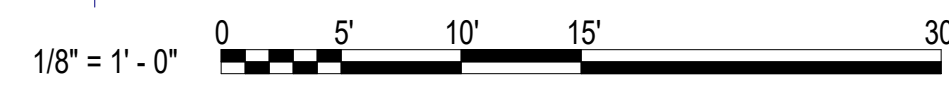

GENERAL NOTES

1. SEE SHEETS S-001 TO S-005 FOR GENERAL NOTES AND DESIGN CRITERIA.
2. SEE ARCHITECTURAL, CIVIL, AND LANDSCAPE DRAWINGS FOR EXTERIOR CONCRETE WORK AT DOORS, SIDEWALKS, ETC.
3. TYPICAL TOP OF SLAB ELEVATION = RE: CIVIL AND ARCH. THIS IS THE DATUM 100'-0". ALL ELEVATIONS ARE REFERENCED FROM THIS ELEVATION.
4. FOUNDATIONS ARE SPREAD, STRIP, MAT FOOTINGS. ALL FOOTINGS TO BE CENTERED BELOW WALLS AND COLUMNS (OR COLUMN GROUP) UNLESS NOTED OTHERWISE.
5. ALL TOP OF FOOTING ELEVATIONS = 98'-0" UNLESS NOTED OTHERWISE.
6. ALL EXTERIOR FOOTINGS MUST BEAR AT OR BELOW MINIMUM BEARING DEPTH AS SPECIFIED IN DESIGN CRITERIA SECTION. PROVIDE ADDITIONAL FOOTING STEPS AS REQUIRED. CONTRACTOR SHALL COORDINATE ALL FOOTING STEP LOCATIONS.
7. RE: PLAN FOR SLAB ON GRADE THICKNESS AND REINFORCING.
8. FOR DIMENSIONS NOT SHOWN ON THESE SHEETS, COORDINATE WALL OPENINGS, ELEVATIONS, SECTIONS, AND DETAILS WITH ARCHITECTURAL, MECHANICAL, ELECTRICAL, AND PLUMBING DRAWINGS.
9. FOR UTILITIES PASSING BELOW FOOTINGS, SEE L17/S-501. CONTRACTOR MUST COORDINATE ALL UTILITY AND FOOTING STEP LOCATIONS. SEE L13/S-501 FOR TYPICAL FOOTING STEP DETAIL AND D9/S-501 FOR UTILITY PENETRATION THROUGH FOUNDATION WALLS.
10. ALL FOOTINGS AT THE END OF A WALL THAT DOES NOT END IN A CORNER CONDITION SHALL EXTEND 1'-0" PAST WALL END.
11. CMU WALLS ARE MW8 UNLESS NOTED OTHERWISE.
12. CONCRETE STEM WALLS ARE CW8 UNDER MW8 CMU AND CW15 UNDER MW8 WALLS WITH CMU VENEER UNLESS NOTED OTHERWISE.
13. RE: ARCH DRAWINGS FOR SLAB SLOPES AND DRAINS, ETC.



US Army Corps of Engineers®

MARK	DESCRIPTION	DATE

DESIGNED BY: A. VALENCIA	ISSUE DATE: NOVEMBER 13, 2025
DRAWN BY: R. CARLSON	SOLICITATION NO.: W812PL25RA0012
CHECKED BY: D. CLAYSON	CONTRACT NO.: W812PL25C0037
SUBMITTED BY: P. PASZCZUK	SIZE: ANSI D
US ARMY CORPS OF ENGINEERS LOS ANGELES DISTRICT	
KORTE CONSTRUCTION 5700 OAKLAND AVE. SUITE 275 ST. LOUIS, MO 63110	

CREECH AIR FORCE BASE, CLARK COUNTY, NV
DISASTER RESILIENCY PROGRAM (DRP) - PHASE 2
494137
HANGAR DOOR FRAMING PLAN - AREA D

SHEET ID
SF128

KEY PLAN

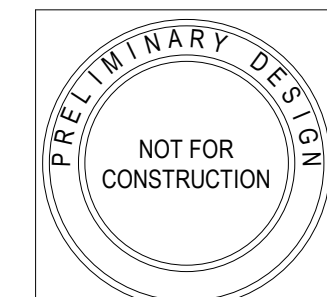
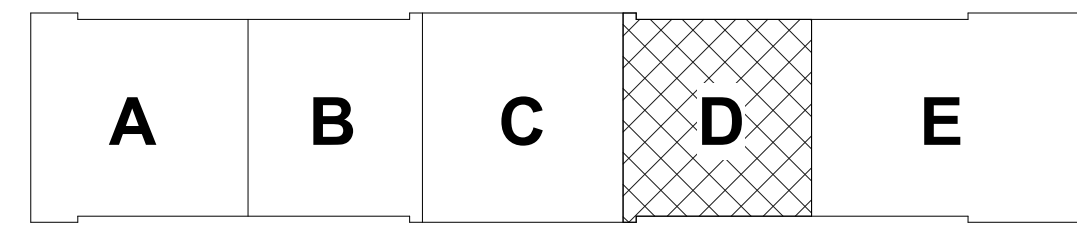

DP-1 95% SUBMISSION

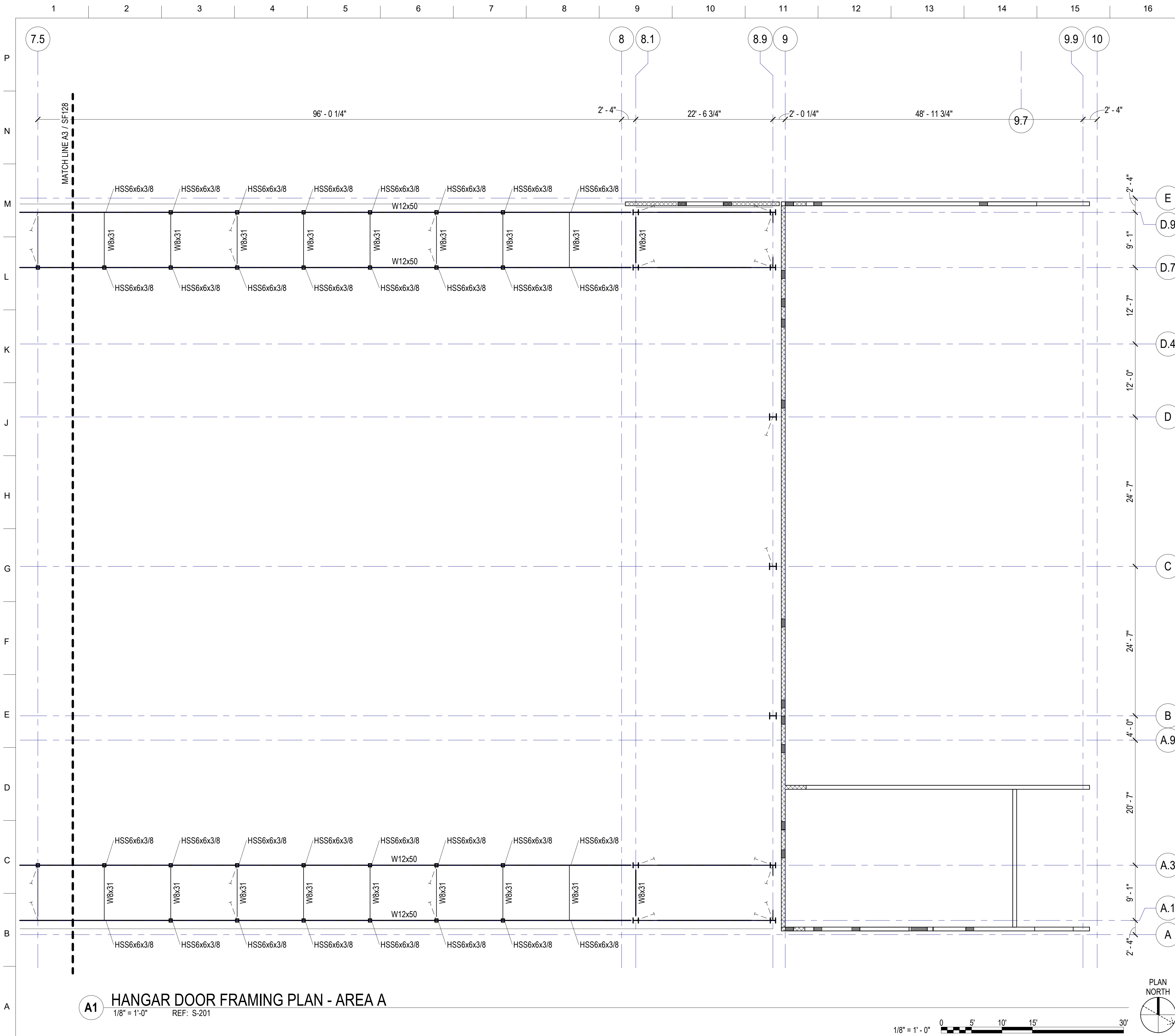

GENERAL NOTES

1. CONTRACTOR IS RESPONSIBLE FOR THE CONSTRUCTION SEQUENCE FOR ALL STRUCTURAL ELEMENTS IN THE PROJECT. CONTRACTOR IS RESPONSIBLE TO PROVIDE ANY SHORING OR BRACING AS NEEDED UNTIL STRUCTURE IS COMPLETE.
2. ALL BEAM-TO-COLUMN CONNECTIONS SHALL BE SINGLE SHEAR TAB CONNECTIONS UNLESS NOTED OTHERWISE. SEE TYPICAL STEEL-TO-STEEL CONNECTION SCHEDULE.
3. CONTRACTOR TO COORDINATE ALL ROOF EDGES AND OPENINGS. OPENINGS LESS THAN 6" IN ALL DIRECTIONS ARE NOT SHOWN IN STRUCTURAL DRAWINGS. RE: L1-L17/S-511 FOR PLACEMENT CRITERIA.
4. RE: SHEETS S-001 - S-005 FOR GENERAL NOTES AND DESIGN CRITERIA.
5. RE: SHEETS S-511 - S-513 FOR TYPICAL ROOF FRAMING DETAILS.
6. RE: SHEETS S-601 - S-602 FOR SCHEDULES.

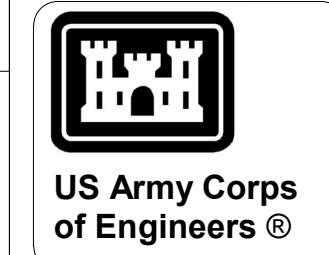

MARK	DESCRIPTION	DATE

DESIGNED BY: A. VALENCIA	ISSUE DATE: NOVEMBER 13, 2025
DRAWN BY: R. CARLSON	SOLICITATION NO.: W812PL25RA0012
CHECKED BY: D. CLAYSON	CONTRACT NO.: W812PL25C0037
SUBMITTED BY: P. PASZCZUK	SIZE: ANSI D
US ARMY CORPS OF ENGINEERS LOS ANGELES DISTRICT KORTE CONSTRUCTION 5700 OAKLAND AVE. SUITE 275 ST. LOUIS, MO 63110	

KEY PLAN

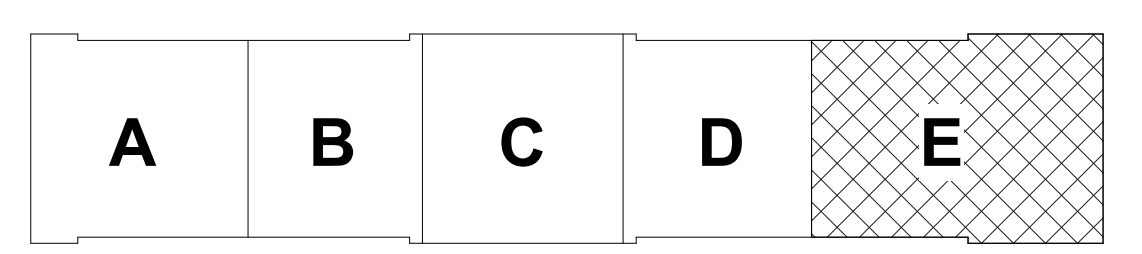

A1 HANGAR DOOR FRAMING PLAN - AREA A
 1/8" = 1'-0" REF: S-201

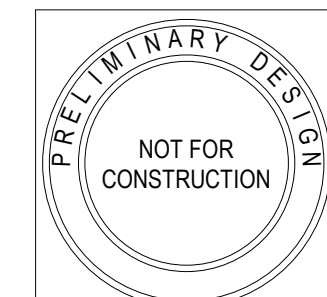

SHEET ID
SF129

DP-1 95% SUBMISSION

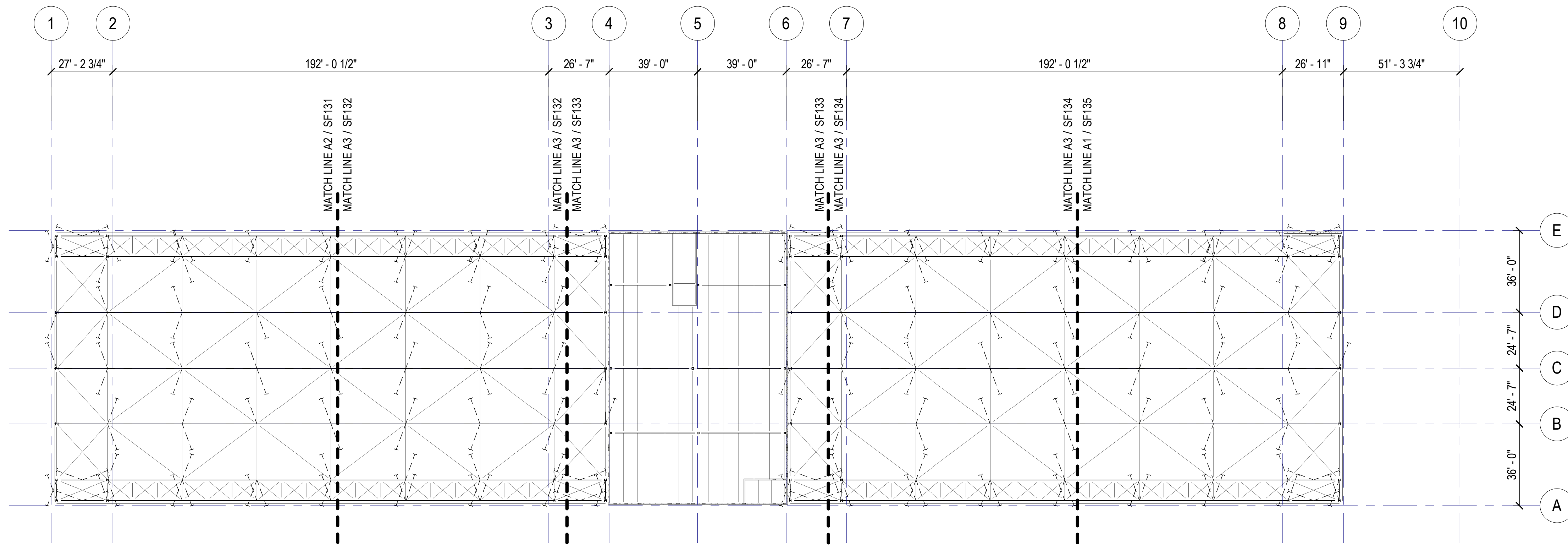

D3 OVERALL BOTTOM CHORD FRAMING PLAN
SCALE: 1" = 30'-0"

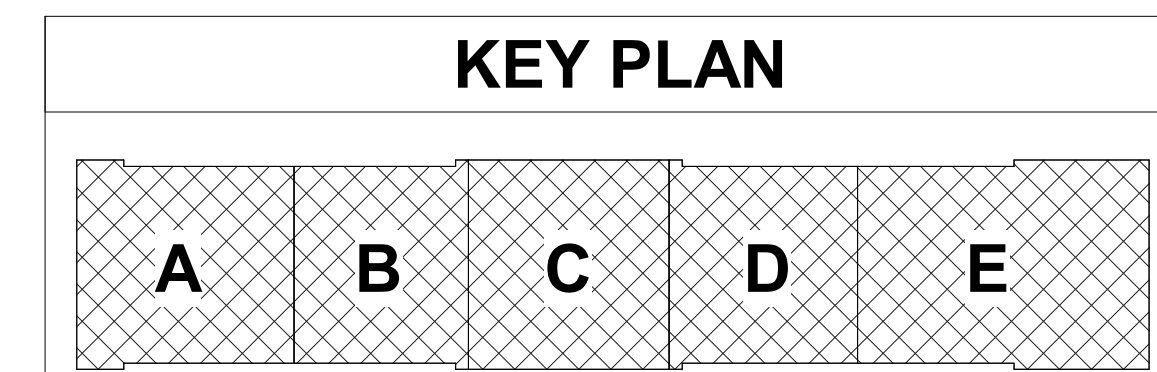

1" = 30' - 0" 0 15' 30' 60' 90'

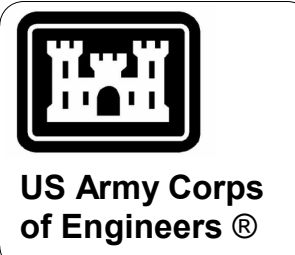
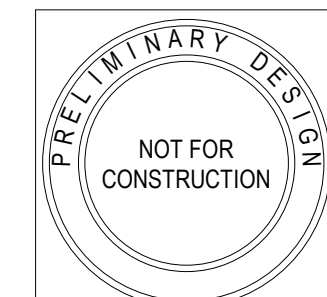

MARK	DESCRIPTION	DATE

DESIGNED BY: A. VALENCIA	ISSUE DATE: NOVEMBER 13, 2025
DRAWN BY: R. CARLSON	SOLICITATION NO.: W812PL25RA0012
CHECKED BY: D. CLAYSON	CONTRACT NO.: W812PL25C0037
SUBMITTED BY: P. PASZCZUK	SIZE: ANSI D
US ARMY CORPS OF ENGINEERS LOS ANGELES DISTRICT	
KORTE CONSTRUCTION 5700 OAKLAND AVE. SUITE 275 ST. LOUIS, MO 63110	

CREECH AIR FORCE BASE, CLARK COUNTY, NV
DISASTER RESILIENCY PROGRAM (DRP) - PHASE 2
494137
OVERALL BOTTOM CHORD FRAMING PLAN

SHEET ID
SF130

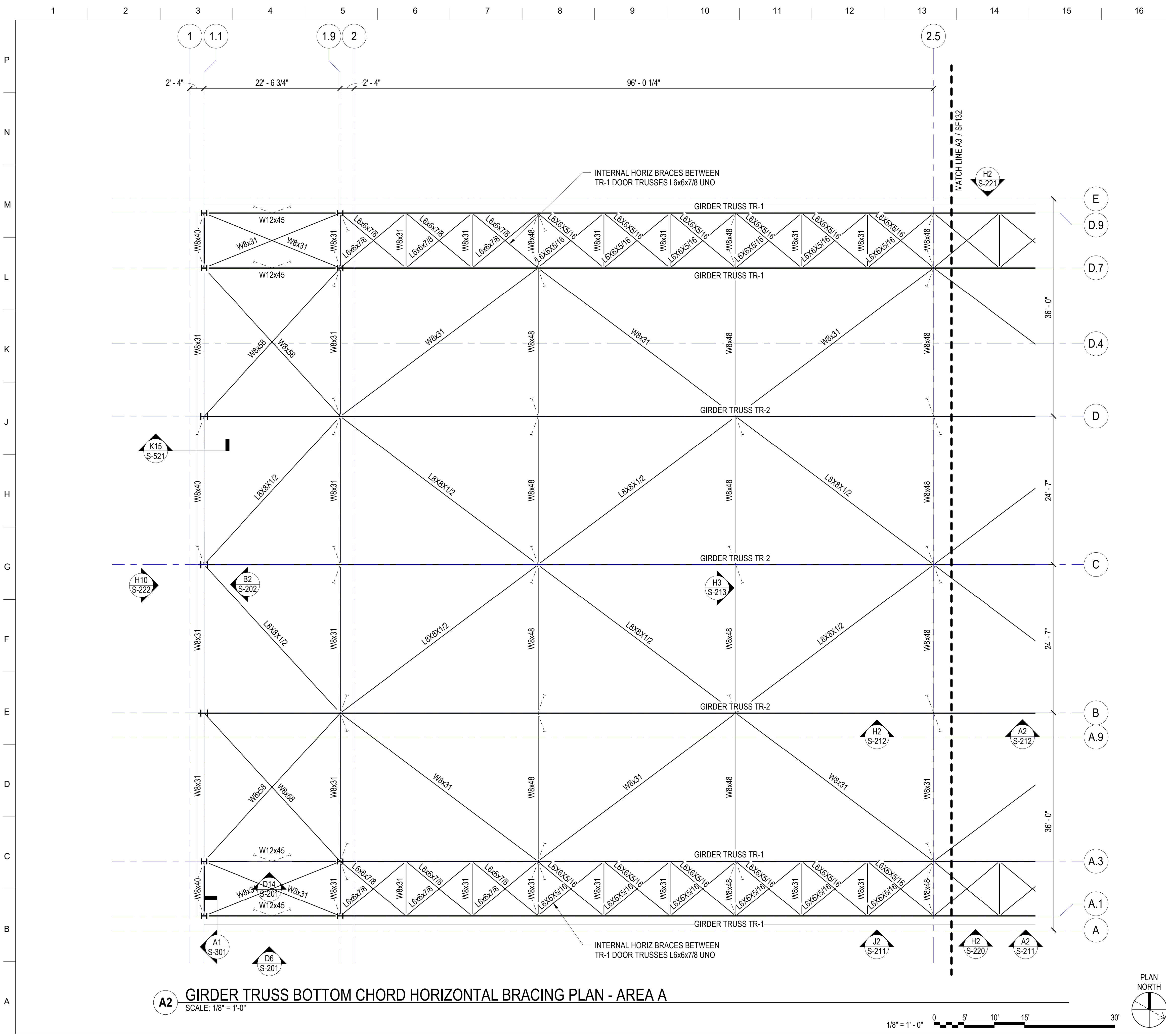

A2 GIRDER TRUSS BOTTOM CHORD HORIZONTAL BRACING PLAN - AREA A
SCALE: 1/8" = 1'-0"

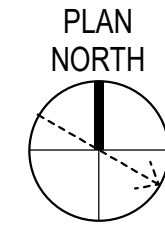
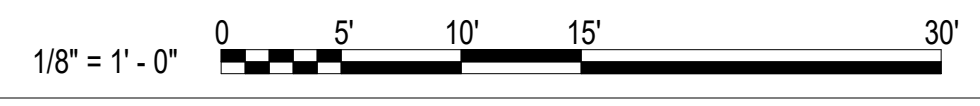

FRAMING NOTES

1. CONTRACTOR IS RESPONSIBLE FOR THE CONSTRUCTION SEQUENCE FOR ALL STRUCTURAL ELEMENTS IN THE PROJECT. CONTRACTOR IS RESPONSIBLE TO PROVIDE ANY SHORING OR BRACING AS NEEDED UNTIL STRUCTURE IS COMPLETE.
2. ALL BEAM-TO-COLUMN CONNECTIONS SHALL BE SINGLE SHEAR TAB CONNECTIONS UNLESS NOTED OTHERWISE. SEE TYPICAL STEEL-TO-STEEL CONNECTION SCHEDULE.
3. CONTRACTOR TO COORDINATE ALL ROOF EDGES AND OPENINGS. OPENINGS LESS THAN 6" IN ALL DIRECTIONS ARE NOT SHOWN IN STRUCTURAL DRAWINGS. RE: L1-L17/S-511 FOR PLACEMENT CRITERIA.
4. RE: SHEETS S-001 - S-005 FOR GENERAL NOTES AND DESIGN CRITERIA.
5. RE: SHEETS S-511 - S-513 FOR TYPICAL ROOF FRAMING DETAILS.
6. RE: SHEETS S-601 - S-602 FOR SCHEDULES.

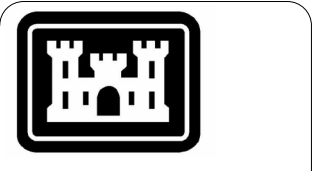

US Army Corps of Engineers®

MARK	DESCRIPTION	DATE

DESIGNED BY: A. VALENCIA	ISSUE DATE: NOVEMBER 13, 2025
DRAWN BY: R. CARLSON	SOLICITATION NO.: WB12PL25RA0012
CHECKED BY: D. CLAYSON	CONTRACT NO.: WB12PL25C0037
SUBMITTED BY: P. PASZCZUK	SIZE: ANSI D

US ARMY CORPS OF ENGINEERS
LOS ANGELES DISTRICT

KORTE CONSTRUCTION
5700 OAKLAND AVE. SUITE 275
ST. LOUIS, MO 63110

CREECH AIR FORCE BASE, CLARK COUNTY, NV
DISASTER RESILIENCY PROGRAM (DRP) - PHASE 2
494137

BOTTOM CHORD FRAMING PLAN - AREA A

SHEET ID
SF131

KEYNOTES

- 1 PROVIDE L4x4x1/4 BRACING AT THIRD POINTS OF BEAM, RE: K15/S-521
- 2 PROVIDE L2x2x1/4 BRACING AT THIRD POINTS OF BEAM, RE: K10/S-521
- 3 PROVIDE L8x8x1/2 BRACING AT THIRD POINTS OF BEAM, RE: E4/S-521
- 4 PROVIDE L8x8x1/2 BRACING AT BEAM HALF POINT, RE: E4/S-521 (SIM)
- 5 PROVIDE L8x8x1/2 BRACING AT THIRD POINTS OF BEAM, RE: A12/S-213

KEY PLAN

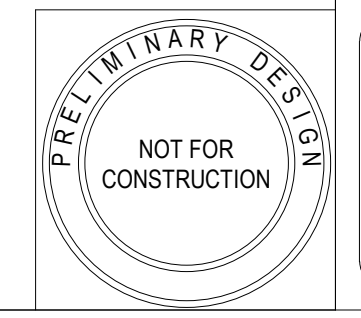
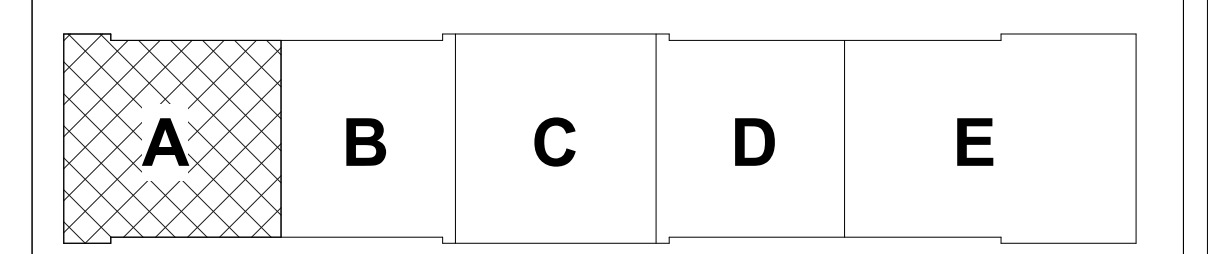

DP-1 95% SUBMISSION

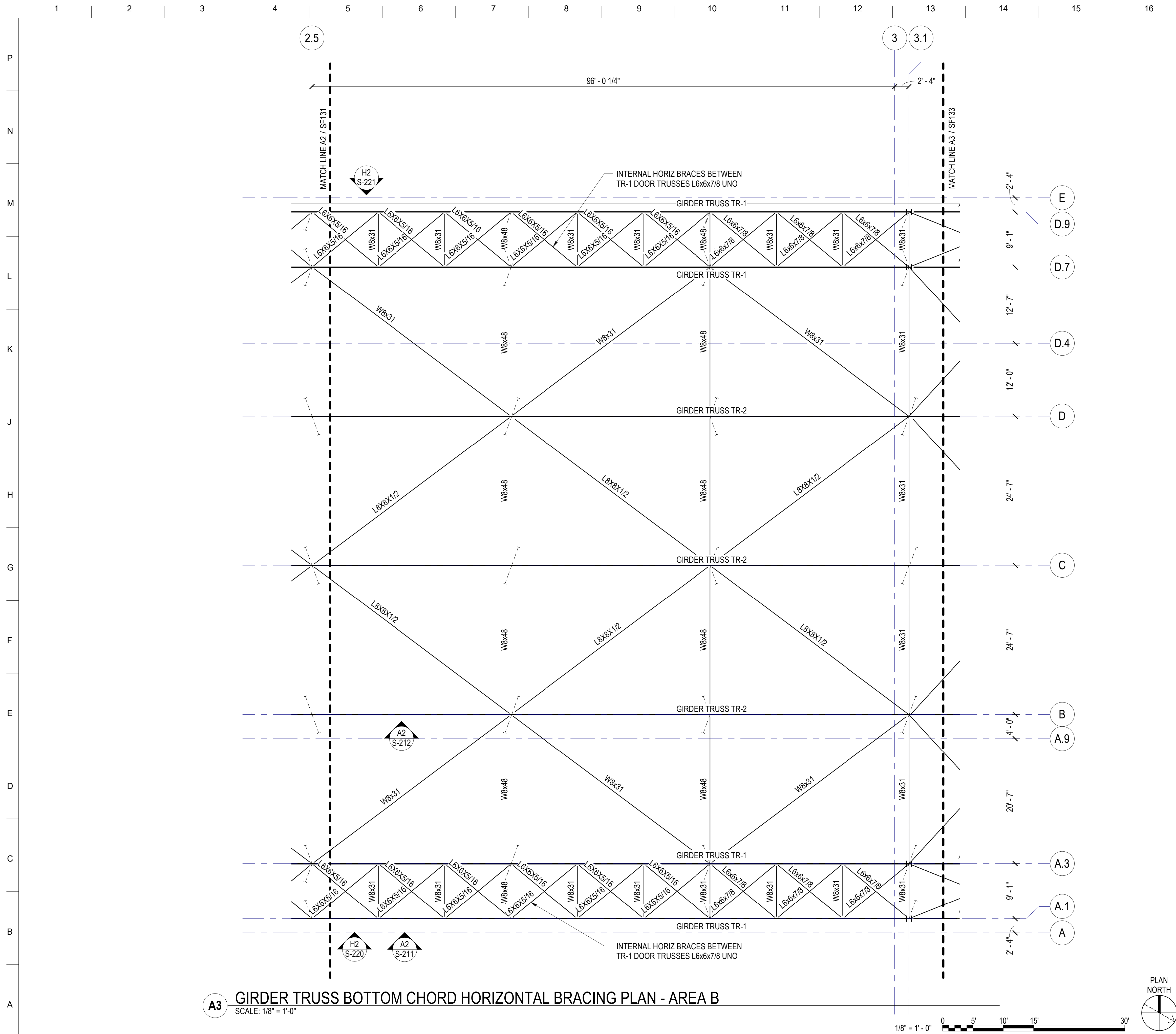

A3 GIRDER TRUSS BOTTOM CHORD HORIZONTAL BRACING PLAN - AREA B
SCALE: 1/8" = 1'-0"

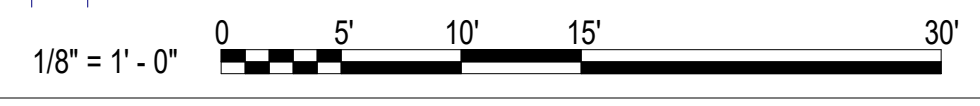

FRAMING NOTES

1. CONTRACTOR IS RESPONSIBLE FOR THE CONSTRUCTION SEQUENCE FOR ALL STRUCTURAL ELEMENTS IN THE PROJECT. CONTRACTOR IS RESPONSIBLE TO PROVIDE ANY SHORING OR BRACING AS NEEDED UNTIL STRUCTURE IS COMPLETE.
2. ALL BEAM-TO-COLUMN CONNECTIONS SHALL BE SINGLE SHEAR TAB CONNECTIONS UNLESS NOTED OTHERWISE. SEE TYPICAL STEEL-TO-STEEL CONNECTION SCHEDULE.
3. CONTRACTOR TO COORDINATE ALL ROOF EDGES AND OPENINGS. OPENINGS LESS THAN 6" IN ALL DIRECTIONS ARE NOT SHOWN IN STRUCTURAL DRAWINGS. RE: L1-L17/S-511 FOR PLACEMENT CRITERIA.
4. RE: SHEETS S-001 - S-005 FOR GENERAL NOTES AND DESIGN CRITERIA.
5. RE: SHEETS S-511 - S-513 FOR TYPICAL ROOF FRAMING DETAILS.
6. RE: SHEETS S-601 - S-602 FOR SCHEDULES.



US Army Corps of Engineers®

MARK	DESCRIPTION	DATE

DESIGNED BY: A. VALENCIA	ISSUE DATE: NOVEMBER 13, 2025
DRAWN BY: R. CARLSON	SOLICITATION NO.: WB12PL25RA0012
CHECKED BY: D. CLAYSON	CONTRACT NO.: WB12PL25C0037
SUBMITTED BY: P. PASZCZUK	SIZE: ANSI D

US ARMY CORPS OF ENGINEERS
LOS ANGELES DISTRICT
KORTE CONSTRUCTION
5700 OAKLAND AVE. SUITE 275
ST. LOUIS, MO 63110

CREECH AIR FORCE BASE, CLARK COUNTY, NV
DISASTER RESILIENCY PROGRAM (DRP) - PHASE 2
494137
BOTTOM CHORD FRAMING PLAN - AREA B

SHEET ID
SF132

KEYNOTES

- ① PROVIDE L4x4x1/4 BRACING AT THIRD POINTS OF BEAM, RE: K15/S-521
- ② PROVIDE L2x2x1/4 BRACING AT THIRD POINTS OF BEAM, RE: K10/S-521
- ③ PROVIDE L8x8x1/2 BRACING AT THIRD POINTS OF BEAM, RE: E4/S-521
- ④ PROVIDE L8x8x1/2 BRACING AT BEAM HALF POINT, RE: E4/S-521 (SIM)
- ⑤ PROVIDE L8x8x1/2 BRACING AT THIRD POINTS OF BEAM, RE: A12/S-213

KEY PLAN

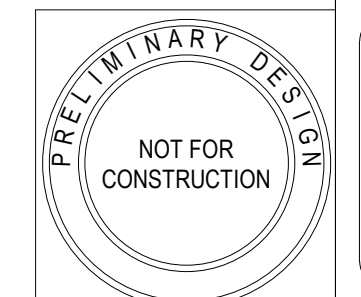
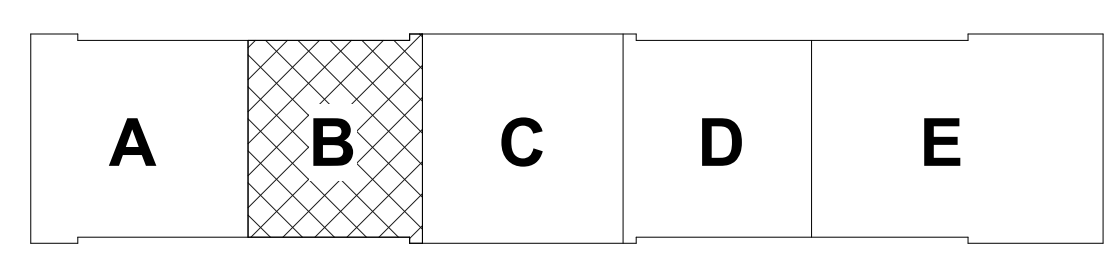

DP-1 95% SUBMISSION

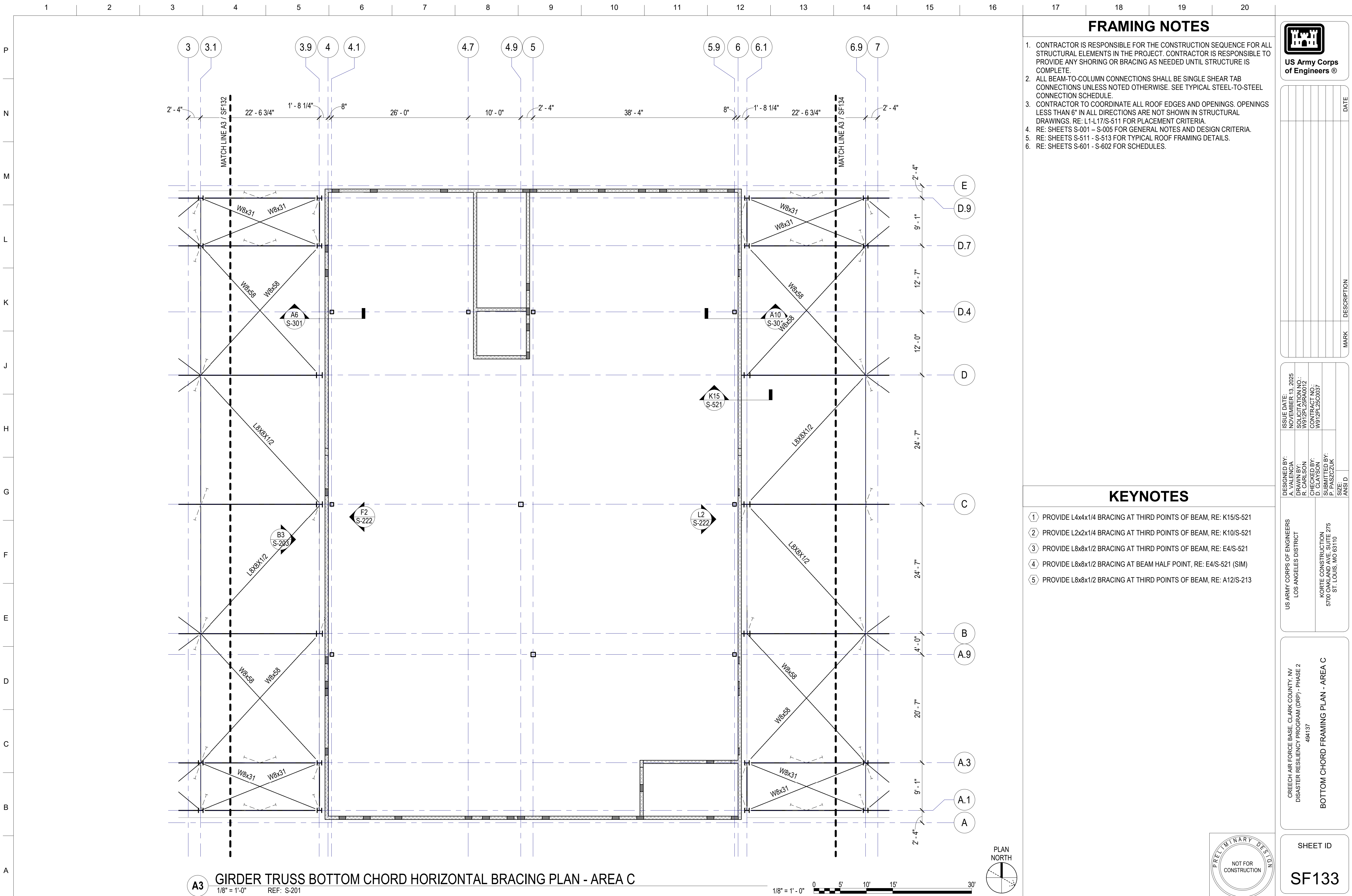

A3 GIRDER TRUSS BOTTOM CHORD HORIZONTAL BRACING PLAN - AREA C
 1/8" = 1'-0" REF: S-201

FRAMING NOTES

1. CONTRACTOR IS RESPONSIBLE FOR THE CONSTRUCTION SEQUENCE FOR ALL STRUCTURAL ELEMENTS IN THE PROJECT. CONTRACTOR IS RESPONSIBLE TO PROVIDE ANY SHORING OR BRACING AS NEEDED UNTIL STRUCTURE IS COMPLETE.
2. ALL BEAM-TO-COLUMN CONNECTIONS SHALL BE SINGLE SHEAR TAB CONNECTIONS UNLESS NOTED OTHERWISE. SEE TYPICAL STEEL-TO-STEEL CONNECTION SCHEDULE.
3. CONTRACTOR TO COORDINATE ALL ROOF EDGES AND OPENINGS. OPENINGS LESS THAN 6" IN ALL DIRECTIONS ARE NOT SHOWN IN STRUCTURAL DRAWINGS. RE: L1-L17/S-511 FOR PLACEMENT CRITERIA.
4. RE: SHEETS S-001 - S-005 FOR GENERAL NOTES AND DESIGN CRITERIA.
5. RE: SHEETS S-511 - S-513 FOR TYPICAL ROOF FRAMING DETAILS.
6. RE: SHEETS S-601 - S-602 FOR SCHEDULES.

KEYNOTES

- ① PROVIDE L4x4x1/4 BRACING AT THIRD POINTS OF BEAM, RE: K15/S-521
- ② PROVIDE L2x2x1/4 BRACING AT THIRD POINTS OF BEAM, RE: K10/S-521
- ③ PROVIDE L8x8x1/2 BRACING AT THIRD POINTS OF BEAM, RE: E4/S-521
- ④ PROVIDE L8x8x1/2 BRACING AT BEAM HALF POINT, RE: E4/S-521 (SIM)
- ⑤ PROVIDE L8x8x1/2 BRACING AT THIRD POINTS OF BEAM, RE: A12/S-213

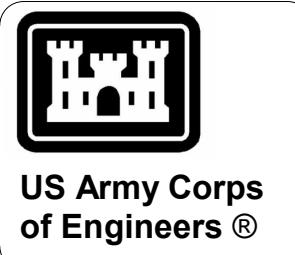

MARK	DESCRIPTION	DATE

DESIGNED BY: A. VALENCIA	ISSUE DATE: NOVEMBER 13, 2025
DRAWN BY: R. CARLSON	SOLICITATION NO.: W812PL25RA0012
CHECKED BY: D. CLAYSON	CONTRACT NO.: W812PL25C0037
SUBMITTED BY: P. PASZCZUK	SIZE: ANSI D

US ARMY CORPS OF ENGINEERS
 LOS ANGELES DISTRICT
 KORTE CONSTRUCTION
 5700 OAKLAND AVE, SUITE 275
 ST. LOUIS, MO 63110

CREECH AIR FORCE BASE, CLARK COUNTY, NV
 DISASTER RESILIENCY PROGRAM (DRP) - PHASE 2
 494137
 BOTTOM CHORD FRAMING PLAN - AREA C

SHEET ID
SF133

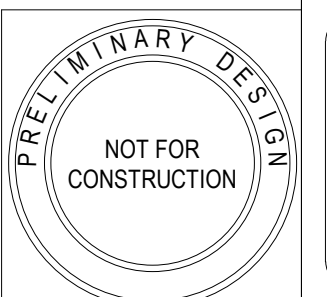

DP-1 95% SUBMISSION

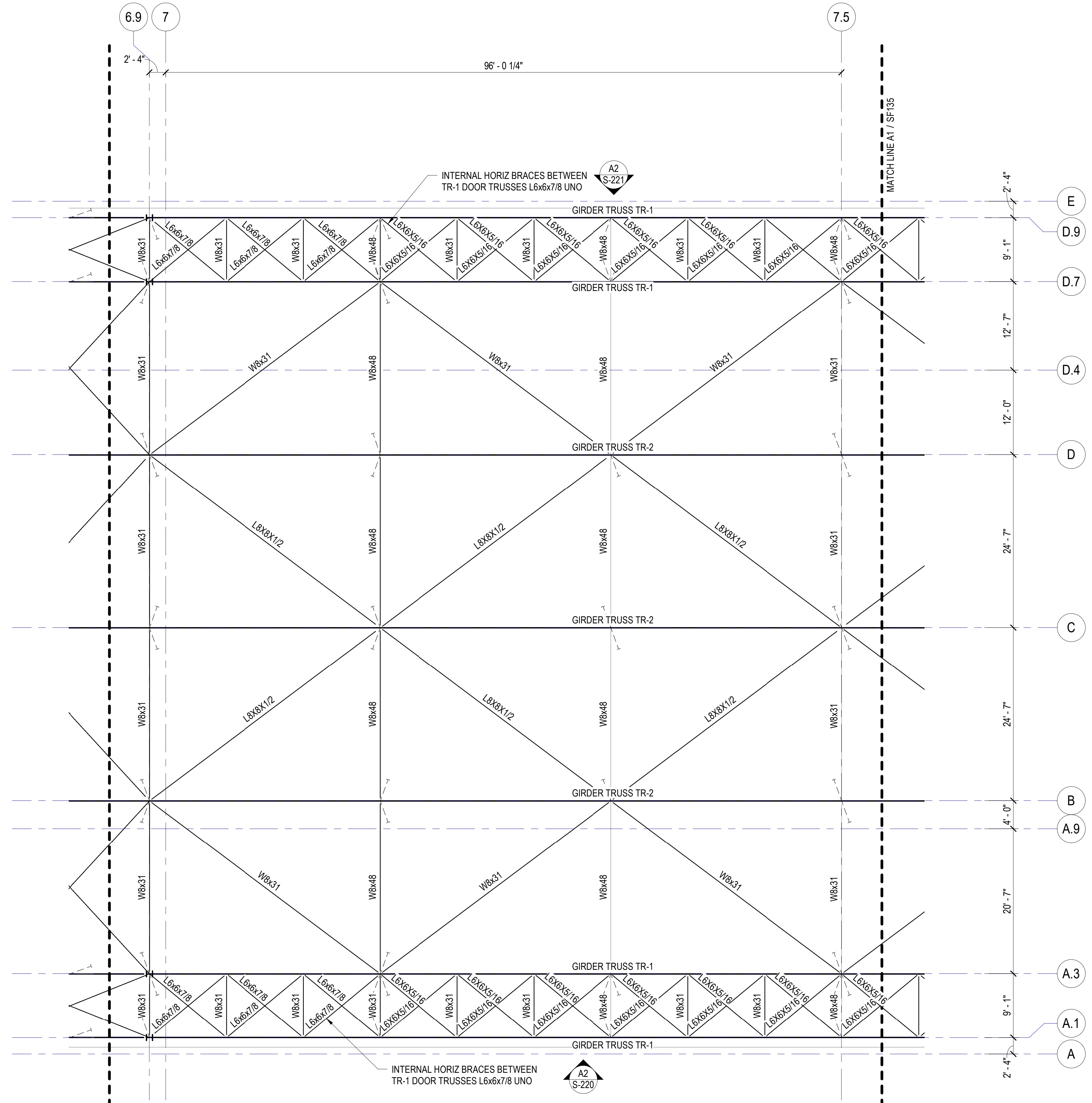

A3 GIRDER TRUSS BOTTOM CHORD HORIZONTAL BRACING PLAN - AREA D
SCALE: 1/8" = 1'-0"

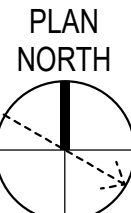
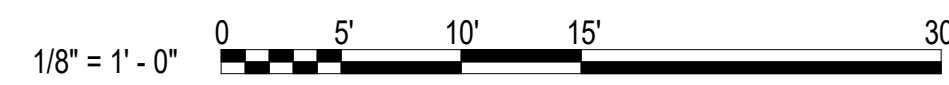

FRAMING NOTES

1. CONTRACTOR IS RESPONSIBLE FOR THE CONSTRUCTION SEQUENCE FOR ALL STRUCTURAL ELEMENTS IN THE PROJECT. CONTRACTOR IS RESPONSIBLE TO PROVIDE ANY SHORING OR BRACING AS NEEDED UNTIL STRUCTURE IS COMPLETE.
2. ALL BEAM-TO-COLUMN CONNECTIONS SHALL BE SINGLE SHEAR TAB CONNECTIONS UNLESS NOTED OTHERWISE. SEE TYPICAL STEEL-TO-STEEL CONNECTION SCHEDULE.
3. CONTRACTOR TO COORDINATE ALL ROOF EDGES AND OPENINGS. OPENINGS LESS THAN 6" IN ALL DIRECTIONS ARE NOT SHOWN IN STRUCTURAL DRAWINGS. RE: L1-L17/S-511 FOR PLACEMENT CRITERIA.
4. RE: SHEETS S-001 - S-005 FOR GENERAL NOTES AND DESIGN CRITERIA.
5. RE: SHEETS S-511 - S-513 FOR TYPICAL ROOF FRAMING DETAILS.
6. RE: SHEETS S-601 - S-602 FOR SCHEDULES.



US Army Corps of Engineers®

MARK	DESCRIPTION	DATE

DESIGNED BY: A. VALENCIA	ISSUE DATE: NOVEMBER 13, 2025
DRAWN BY: R. CARLSON	SOLICITATION NO.: WB12PL25RA0012
CHECKED BY: D. CLAYSON	CONTRACT NO.: WB12PL25C0037
SUBMITTED BY: P. PASZCZUK	SIZE: ANSI D

US ARMY CORPS OF ENGINEERS
LOS ANGELES DISTRICT

KORTE CONSTRUCTION
5700 OAKLAND AVE. SUITE 275
ST. LOUIS, MO 63110

KEYNOTES

- ① PROVIDE L4x4x1/4 BRACING AT THIRD POINTS OF BEAM, RE: K15/S-521
- ② PROVIDE L2x2x1/4 BRACING AT THIRD POINTS OF BEAM, RE: K10/S-521
- ③ PROVIDE L8x8x1/2 BRACING AT THIRD POINTS OF BEAM, RE: E4/S-521
- ④ PROVIDE L8x8x1/2 BRACING AT BEAM HALF POINT, RE: E4/S-521 (SIM)
- ⑤ PROVIDE L8x8x1/2 BRACING AT THIRD POINTS OF BEAM, RE: A12/S-213

KEY PLAN

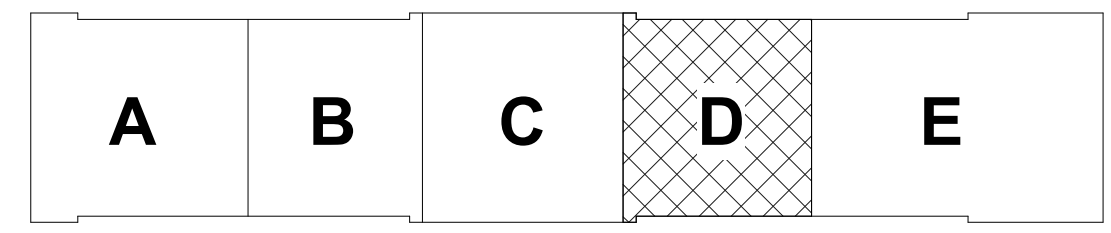

CREECH AIR FORCE BASE, CLARK COUNTY, NV
DISASTER RESILIENCY PROGRAM (DRP) - PHASE 2
494137

BOTTOM CHORD FRAMING PLAN - AREA D

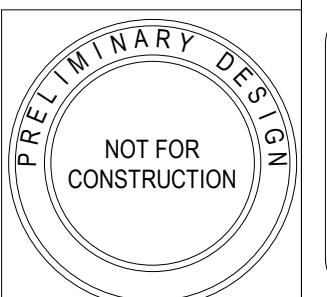

SHEET ID
SF134

DP-1 95% SUBMISSION

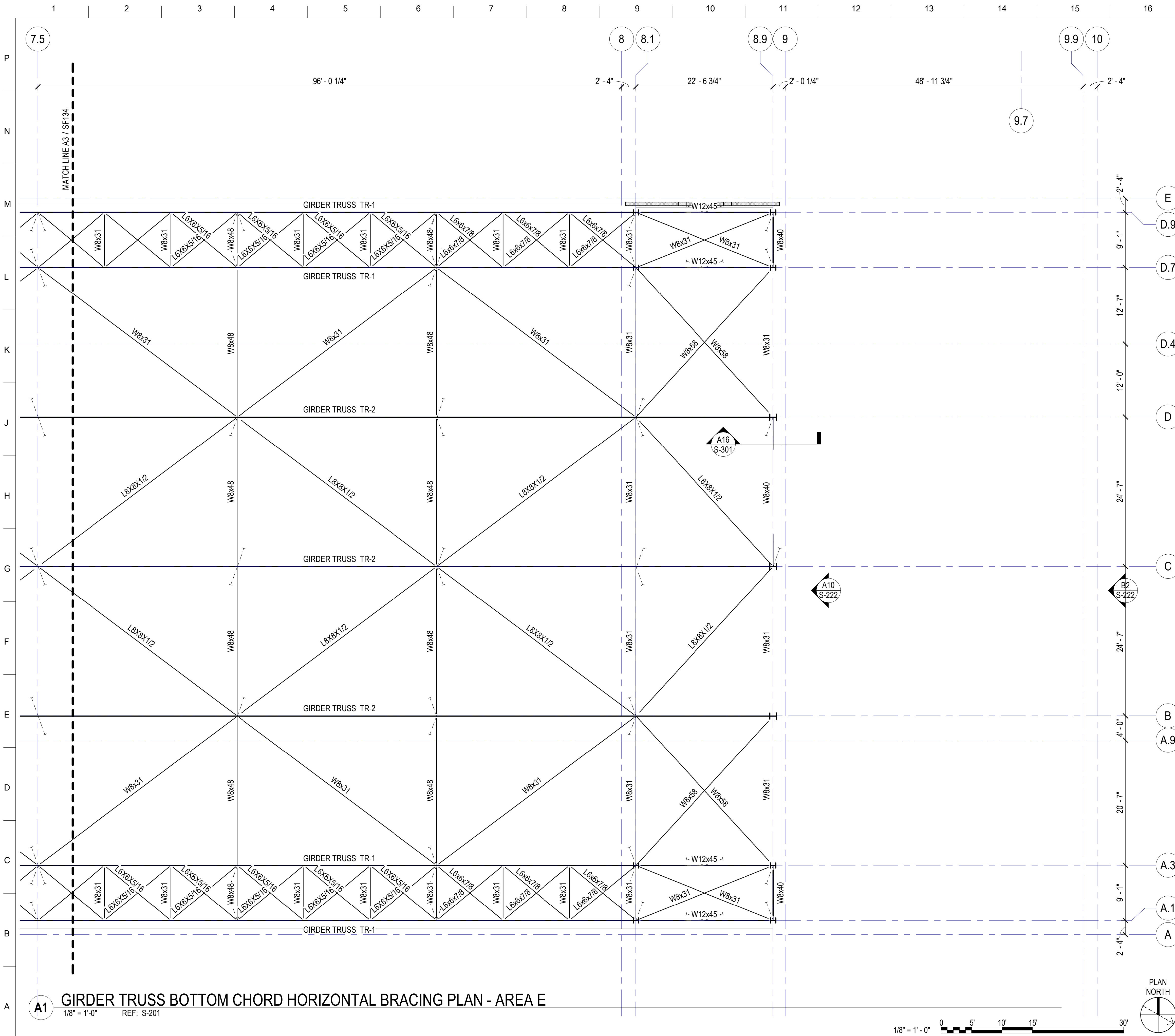

FRAMING NOTES

1. CONTRACTOR IS RESPONSIBLE FOR THE CONSTRUCTION SEQUENCE FOR ALL STRUCTURAL ELEMENTS IN THE PROJECT. CONTRACTOR IS RESPONSIBLE TO PROVIDE ANY SHORING OR BRACING AS NEEDED UNTIL STRUCTURE IS COMPLETE.
2. ALL BEAM-TO-COLUMN CONNECTIONS SHALL BE SINGLE SHEAR TAB CONNECTIONS UNLESS NOTED OTHERWISE. SEE TYPICAL STEEL-TO-STEEL CONNECTION SCHEDULE.
3. CONTRACTOR TO COORDINATE ALL ROOF EDGES AND OPENINGS. OPENINGS LESS THAN 6" IN ALL DIRECTIONS ARE NOT SHOWN IN STRUCTURAL DRAWINGS. RE: L1-L17/S-511 FOR PLACEMENT CRITERIA.
4. RE: SHEETS S-001 - S-005 FOR GENERAL NOTES AND DESIGN CRITERIA.
5. RE: SHEETS S-511 - S-513 FOR TYPICAL ROOF FRAMING DETAILS.
6. RE: SHEETS S-601 - S-602 FOR SCHEDULES.



US Army Corps of Engineers®

MARK	DESCRIPTION	DATE

DESIGNED BY: A. VALENCIA	ISSUE DATE: NOVEMBER 13, 2025
DRAWN BY: R. CARLSON	SOLICITATION NO.: W812PL25RA0012
CHECKED BY: D. CLAYSON	CONTRACT NO.: W812PL25C0037
SUBMITTED BY: P. PASZCZUK	ANSI D

KEYNOTES

- 1 PROVIDE L4x4x1/4 BRACING AT THIRD POINTS OF BEAM, RE: K15/S-521
- 2 PROVIDE L2x2x1/4 BRACING AT THIRD POINTS OF BEAM, RE: K10/S-521
- 3 PROVIDE L8x8x1/2 BRACING AT THIRD POINTS OF BEAM, RE: E4/S-521
- 4 PROVIDE L8x8x1/2 BRACING AT BEAM HALF POINT, RE: E4/S-521 (SIM)
- 5 PROVIDE L8x8x1/2 BRACING AT THIRD POINTS OF BEAM, RE: A12/S-213

KEY PLAN

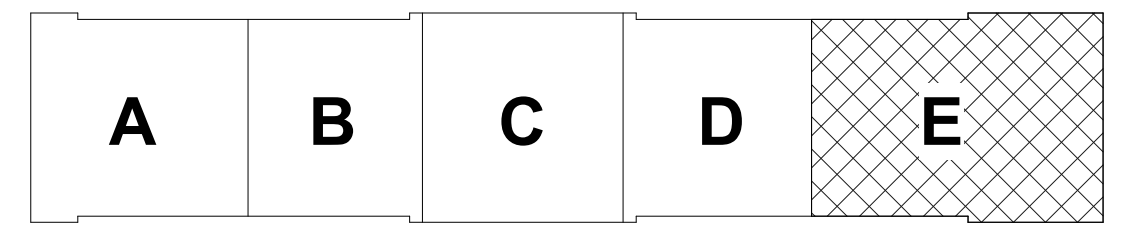

A1 GIRDER TRUSS BOTTOM CHORD HORIZONTAL BRACING PLAN - AREA E

1/8" = 1'-0" REF: S-201

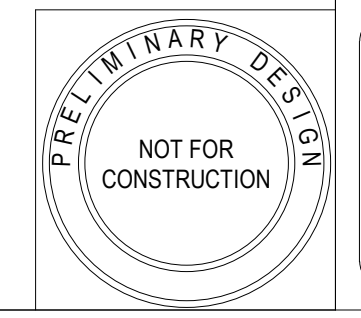
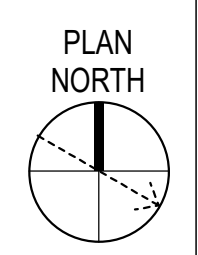

SHEET ID
SF135

CREECH AIR FORCE BASE, CLARK COUNTY, NV
DISASTER RESILIENCY PROGRAM (DRP) - PHASE 2
494137
BOTTOM CHORD FRAMING PLAN - AREA E

DP-1 95% SUBMISSION



E3 OVERALL ROOF FRAMING PLAN
SCALE: 1" = 30'-0"

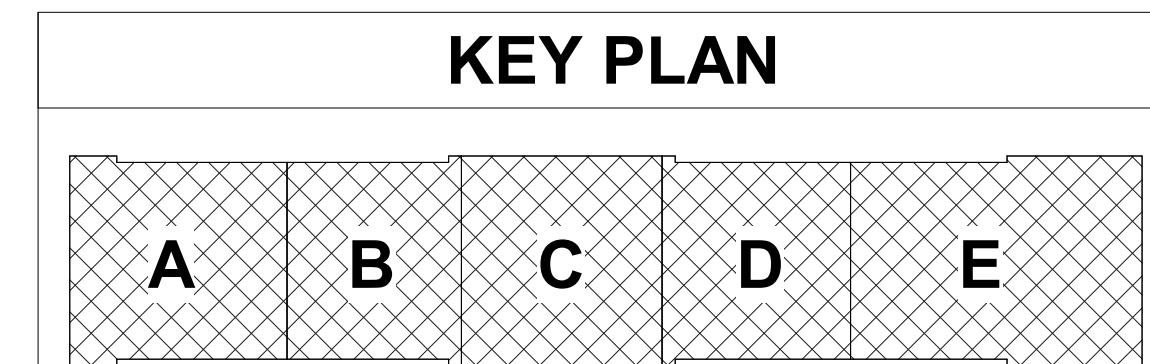

1" = 30' - 0"
0 15' 30' 60' 90'

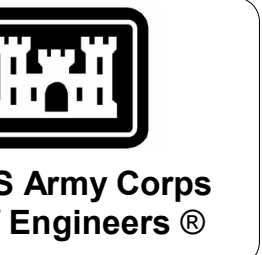
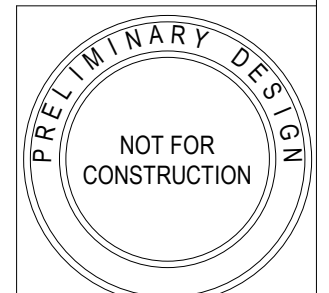
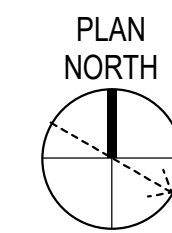

US Army Corps of Engineers®

MARK	DESCRIPTION	DATE

DESIGNED BY: A. VALENCIA	ISSUE DATE: NOVEMBER 13, 2025
DRAWN BY: R. CARLSON	SOLICITATION NO.: W812PL25RA0012
CHECKED BY: D. CLAYSON	CONTRACT NO.: W812PL25C0037
SUBMITTED BY: P. PASZCZUK	
SIZE: ANSI D	

US ARMY CORPS OF ENGINEERS
LOS ANGELES DISTRICT

KORTE CONSTRUCTION
5700 OAKLAND AVE, SUITE 275
ST. LOUIS, MO 63110

CREECH AIR FORCE BASE, CLARK COUNTY, NV
DISASTER RESILIENCY PROGRAM (DRP) - PHASE 2
494137
OVERALL ROOF FRAMING PLAN

SHEET ID
SF140

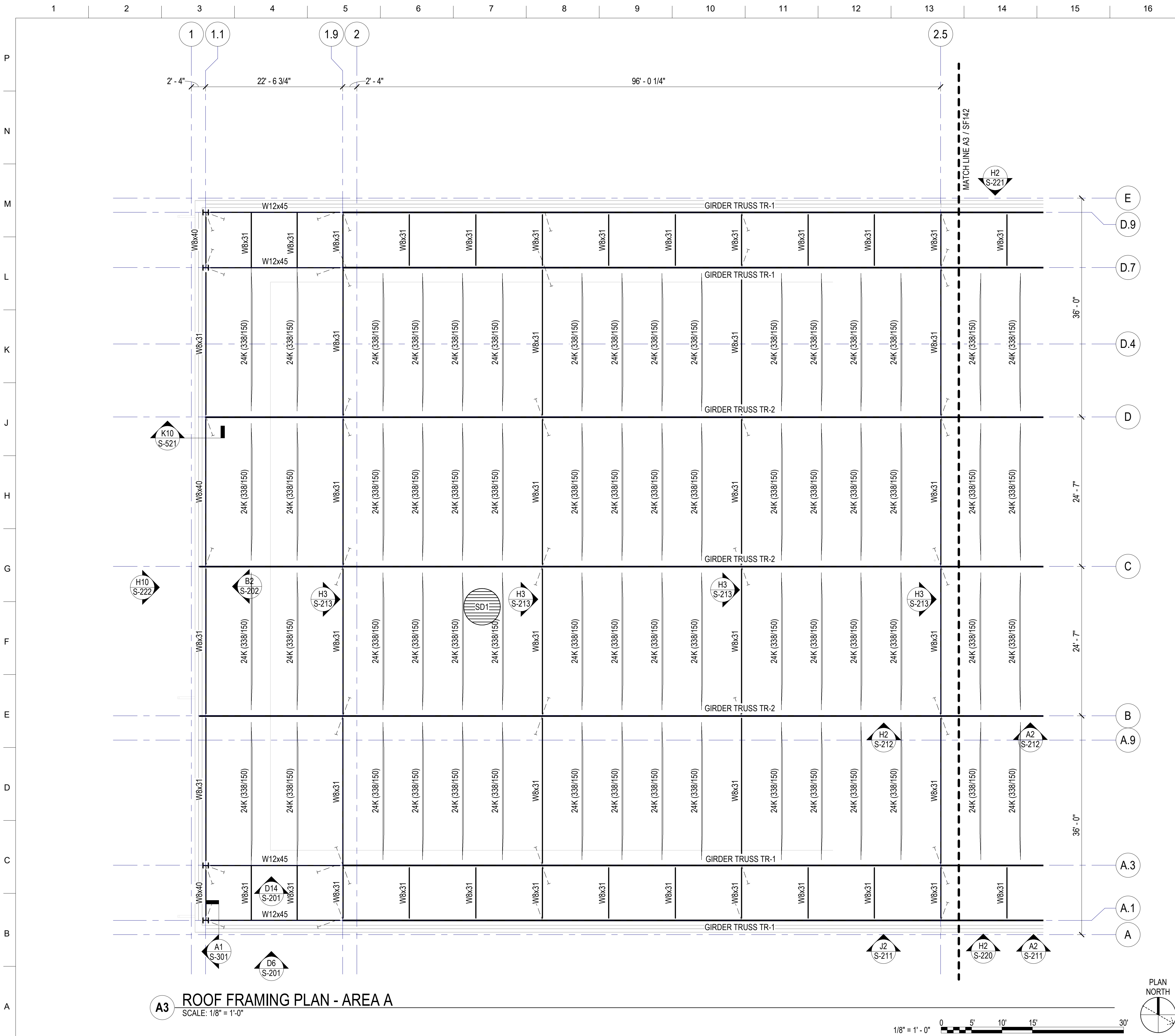

A3 ROOF FRAMING PLAN - AREA A
SCALE: 1/8" = 1'-0"



ROOF FRAMING NOTES

- CONTRACTOR IS RESPONSIBLE FOR THE CONSTRUCTION SEQUENCE FOR ALL STRUCTURAL ELEMENTS IN THE PROJECT. CONTRACTOR IS RESPONSIBLE TO PROVIDE ANY SHORING OR BRACING AS NEEDED UNTIL STRUCTURE IS COMPLETE.
- ALL BEAM-TO-COLUMN CONNECTIONS SHALL BE SINGLE SHEAR TAB CONNECTIONS UNLESS NOTED OTHERWISE. SEE TYPICAL STEEL-TO-STEEL CONNECTION SCHEDULE.
- SHOP DRAWINGS MUST BE PRODUCED FOR ALL JOISTS AND SHALL BE SUBMITTED TO THE ENGINEER FOR APPROVAL PRIOR TO FABRICATION. CALCULATIONS SHALL BE SUBMITTED WITH THE SHOP DRAWINGS AND SHALL BEAR THE STAMP OF A LICENSED ENGINEER.
- OPEN WEB STEEL JOISTS SHALL BE DESIGNED BY THE MANUFACTURER TO SUPPORT THE MECHANICAL, AXIAL (WL/EQ), LATERAL, POINT, AND UNIFORM LOADS SHOWN ON PLANS AND IN DETAILS. LOADS SHOWN ARE ASD MAGNITUDE LOADS UNLESS NOTED OTHERWISE.
- THE STEEL JOIST SUPPLIER IS RESPONSIBLE IN DESIGNING ALL JOISTS, INCLUDING SLOPE, CAMBER, BEARING ENDS, ETC. ALL DESIGNS SHALL BE IN ACCORDANCE WITH SJI SPECIFICATIONS WITH A MAXIMUM DEFLECTION OF JOISTS OF TL/180 AND LL/240.
- HORIZONTAL AND CROSS BRIDGING SHALL BE SIZED, LOCATED, AND SUPPLIED BY THE JOIST MANUFACTURER.
- ALL STABILIZER PLATES SHALL BE 6"x6" x CHORD GAP-1/4" WITH A 3/4" DIAMETER HOLE, AND MUST EXTEND 3" MINIMUM BELOW THE BOTTOM CHORD.
- ALL CONCENTRATED LOADS GREATER THAN 100 POUNDS SUPPORTED BY OPEN WEB JOISTS SHALL BE LOCATED WITHIN 6" OF PANEL POINT. OTHERWISE, JOIST SHALL BE REINFORCED WITH AN ADDITIONAL WEB MEMBER. (RE: H1/S-511)
- BOTTOM CHORD OF ANY JOIST SHALL NOT BE USED TO BRACE ANY MISC EQUIPMENT.
- JOIST BRIDGING SHALL NEVER BE USED TO SUPPORT HANGING LOADS.
- JOIST LOADS SHOWN ON PLAN WITH THE JOIST DESIGNATION "K (XX/XX)" ACCOUNTS FOR TOTAL LOAD/LIVE LOAD (ASD).
- OPEN WEB STEEL JOISTS SHALL BE DESIGNED FOR A NET UPLIFT DUE TO WIND LOADING, RE: SHEET S-005.
- STEEL JOISTS SHALL BE DESIGNED FOR AN ADDITIONAL VERT LIVE LOAD (ASD) OF +/-500# AT EACH PANEL POINT
- STANDARD JOIST SEAT DEPTH SHALL BE 2 1/2". CONTRACTOR TO COORDINATE TOP OF GIRDERS USING 2 1/2" JOIST SEAT DEPTH UNO.
- CONTRACTOR TO COORDINATE ALL ROOF EDGES AND OPENINGS. OPENINGS LESS THAN 6" IN ALL DIRECTIONS ARE NOT SHOWN IN STRUCTURAL DRAWINGS. RE: L1-L17/S-511 FOR PLACEMENT CRITERIA.
- RE: SHEETS S-001 - S-005 FOR GENERAL NOTES AND DESIGN CRITERIA.
- RE: SHEETS S-511 - S-513 FOR TYPICAL ROOF FRAMING DETAILS.
- RE: SHEETS S-601 - S-602 FOR SCHEDULES.

KEYNOTES

- HANGING FAN ON BOTTOM CHORD OF TRUSS ON GRID D. APPROXIMATE WEIGHT OF 300LBS (DL ASD). RE: ARCH/MEP FOR EXACT LOCATION. RE: MFR FOR ATTACHMENT
- PROVIDE L4x4x1/4 BRACING AT THIRD POINTS OF BEAM
- PROVIDE L8x8x1/2 BRACING AT THIRD POINTS OF BEAM
- PROVIDE L8x8x1/2 BRACING AT BEAM HALF POINT
- SUPPORT FRAMING FOR 1-TON MONORAIL HOIST CRANE

CRANE COORDINATION AND LATERAL BRACING IN PROGRESS

KEY PLAN

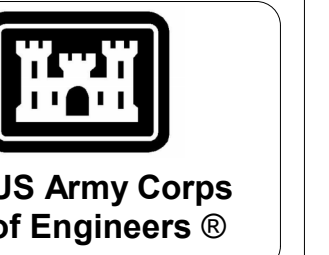
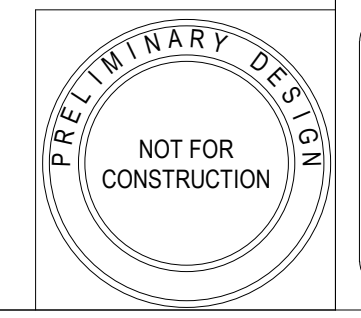
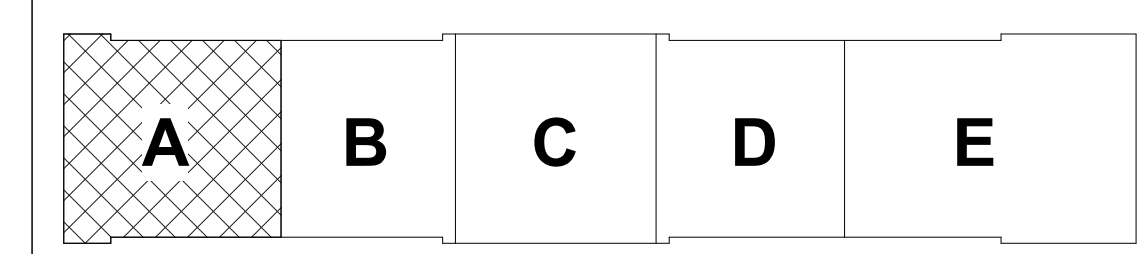

MARK	DESCRIPTION	DATE

DESIGNED BY: A. VALENCIA	ISSUE DATE: NOVEMBER 13, 2025
DRAWN BY: R. CARLSON	SOLICITATION NO.:
CHECKED BY: D. CLAYSON	W912PL259RA0012
SUBMITTED BY: P. PASZCZUK	CONTRACT NO.:
SIZE: ANSI D	W912PL25C0037

US ARMY CORPS OF ENGINEERS
LOS ANGELES DISTRICT

KORTE CONSTRUCTION
5700 OAKLAND AVE. SUITE 275
ST. LOUIS, MO 63110

CREECH AIR FORCE BASE, CLARK COUNTY, NV
DISASTER RESILIENCY PROGRAM (DRP) - PHASE 2
494137

ROOF FRAMING PLAN - AREA A

SHEET ID
SF141

DP-1 95% SUBMISSION

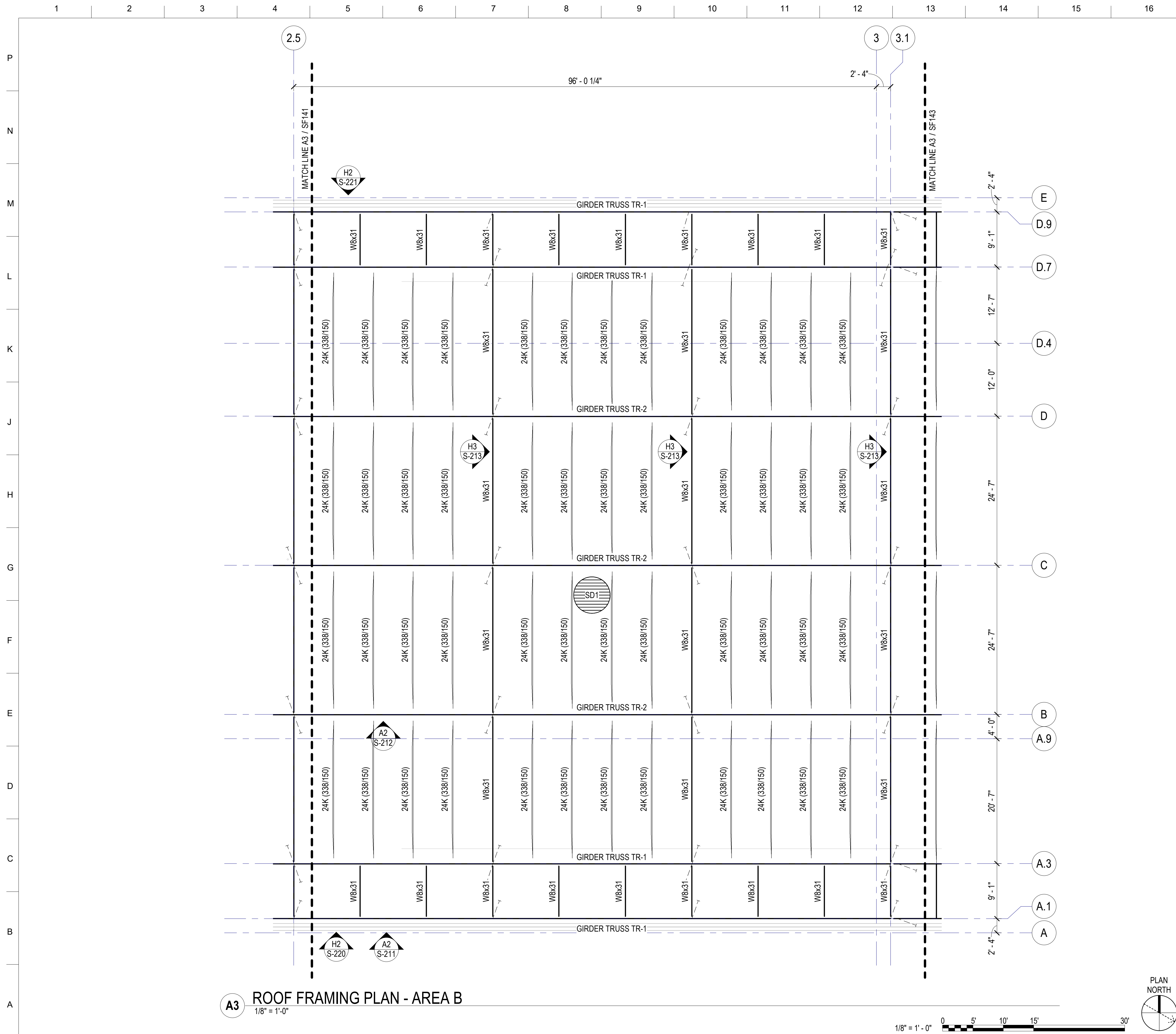

A3 ROOF FRAMING PLAN - AREA B
1/8" = 1'-0"

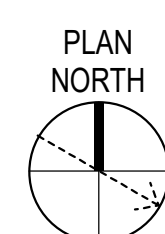
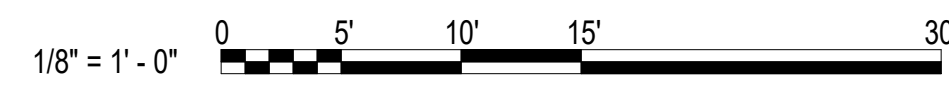

ROOF FRAMING NOTES

1. CONTRACTOR IS RESPONSIBLE FOR THE CONSTRUCTION SEQUENCE FOR ALL STRUCTURAL ELEMENTS IN THE PROJECT. CONTRACTOR IS RESPONSIBLE TO PROVIDE ANY SHORING OR BRACING AS NEEDED UNTIL STRUCTURE IS COMPLETE.
2. ALL BEAM-TO-COLUMN CONNECTIONS SHALL BE SINGLE SHEAR TAB CONNECTIONS UNLESS NOTED OTHERWISE. SEE TYPICAL STEEL-TO-STEEL CONNECTION SCHEDULE.
3. SHOP DRAWINGS MUST BE PRODUCED FOR ALL JOISTS AND SHALL BE SUBMITTED TO THE ENGINEER FOR APPROVAL PRIOR TO FABRICATION. CALCULATIONS SHALL BE SUBMITTED WITH THE SHOP DRAWINGS AND SHALL BEAR THE STAMP OF A LICENSED ENGINEER.
4. OPEN WEB STEEL JOISTS SHALL BE DESIGNED BY THE MANUFACTURER TO SUPPORT THE MECHANICAL, AXIAL (WL/EQ), LATERAL, POINT, AND UNIFORM LOADS SHOWN ON PLANS AND IN DETAILS. LOADS SHOWN ARE ASD MAGNITUDE LOADS UNLESS NOTED OTHERWISE.
5. THE STEEL JOIST SUPPLIER IS RESPONSIBLE IN DESIGNING ALL JOISTS, INCLUDING SLOPE, CAMBER, BEARING ENDS, ETC. ALL DESIGNS SHALL BE IN ACCORDANCE WITH SJI SPECIFICATIONS WITH A MAXIMUM DEFLECTION OF JOISTS OF TL/180 AND LL/240.
6. HORIZONTAL AND CROSS BRIDGING SHALL BE SIZED, LOCATED, AND SUPPLIED BY THE JOIST MANUFACTURER.
7. ALL STABILIZER PLATES SHALL BE 6"x6" x CHORD GAP-1/4" WITH A 3/4" DIAMETER HOLE, AND MUST EXTEND 3" MINIMUM BELOW THE BOTTOM CHORD.
8. ALL CONCENTRATED LOADS GREATER THAN 100 POUNDS SUPPORTED BY OPEN WEB JOISTS SHALL BE LOCATED WITHIN 6" OF PANEL POINT. OTHERWISE, JOIST SHALL BE REINFORCED WITH AN ADDITIONAL WEB MEMBER. (RE: H1/S-511)
9. BOTTOM CHORD OF ANY JOIST SHALL NOT BE USED TO BRACE ANY MISC EQUIPMENT.
10. JOIST BRIDGING SHALL NEVER BE USED TO SUPPORT HANGING LOADS.
11. JOIST LOADS SHOWN ON PLAN WITH THE JOIST DESIGNATION "K (XX/XX)" ACCOUNTS FOR TOTAL LOAD/LIVE LOAD (ASD).
12. OPEN WEB STEEL JOISTS SHALL BE DESIGNED FOR A NET UPLIFT DUE TO WIND LOADING, RE: SHEET S-005.
13. STEEL JOISTS SHALL BE DESIGNED FOR AN ADDITIONAL VERT LIVE LOAD (ASD) OF +/-500# AT EACH PANEL POINT
14. STANDARD JOIST SEAT DEPTH SHALL BE 2 1/2". CONTRACTOR TO COORDINATE TOP OF GIRDERS USING 2 1/2" JOIST SEAT DEPTH UNO.
15. CONTRACTOR TO COORDINATE ALL ROOF EDGES AND OPENINGS. OPENINGS LESS THAN 6" IN ALL DIRECTIONS ARE NOT SHOWN IN STRUCTURAL DRAWINGS. RE: L-117/S-511 FOR PLACEMENT CRITERIA.
16. RE: SHEETS S-001 - S-005 FOR GENERAL NOTES AND DESIGN CRITERIA.
17. RE: SHEETS S-511 - S-513 FOR TYPICAL ROOF FRAMING DETAILS.
18. RE: SHEETS S-601 - S-602 FOR SCHEDULES.

KEYNOTES

- 1 HANGING FAN ON BOTTOM CHORD OF TRUSS ON GRID D. APPROXIMATE WEIGHT OF 300LBS (DL ASD). RE: ARCH/MEP FOR EXACT LOCATION. RE: MFR FOR ATTACHMENT
- 2 PROVIDE L4x4x1/4 BRACING AT THIRD POINTS OF BEAM
- 3 PROVIDE L8x8x1/2 BRACING AT THIRD POINTS OF BEAM
- 4 PROVIDE L8x8x1/2 BRACING AT BEAM HALF POINT
- 5 SUPPORT FRAMING FOR 1-TON MONORAIL HOIST CRANE

CRANE COORDINATION AND LATERAL BRACING IN PROGRESS

KEY PLAN

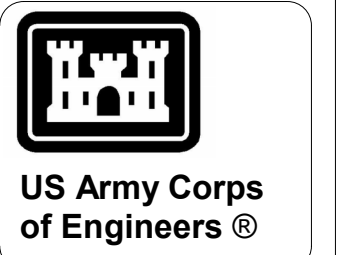
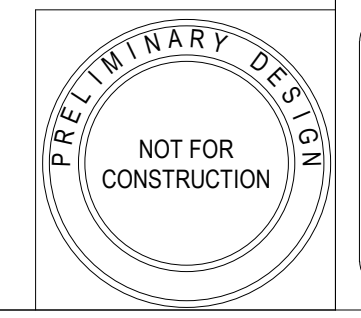
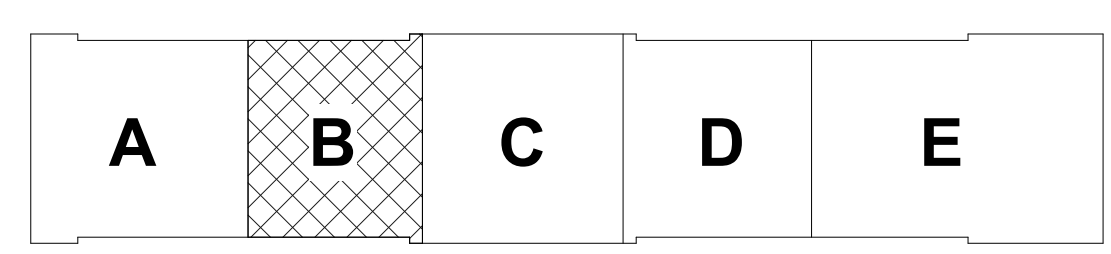

MARK	DESCRIPTION	DATE

DESIGNED BY: A. VALENCIA	ISSUE DATE: NOVEMBER 13, 2025
DRAWN BY: R. CARLSON	SOLICITATION NO.: WB12PL25RA0012
CHECKED BY: D. CLAYSON	CONTRACT NO.: WB12PL25C0037
SUBMITTED BY: P. PASZCZUK	SIZE: ANSI D

US ARMY CORPS OF ENGINEERS
LOS ANGELES DISTRICT

KORTE CONSTRUCTION
5700 OAKLAND AVE. SUITE 275
ST. LOUIS, MO 63110

CREECH AIR FORCE BASE, CLARK COUNTY, NV
DISASTER RESILIENCY PROGRAM (DRP) - PHASE 2
494137

ROOF FRAMING PLAN - AREA B

SHEET ID
SF142

DP-1 95% SUBMISSION

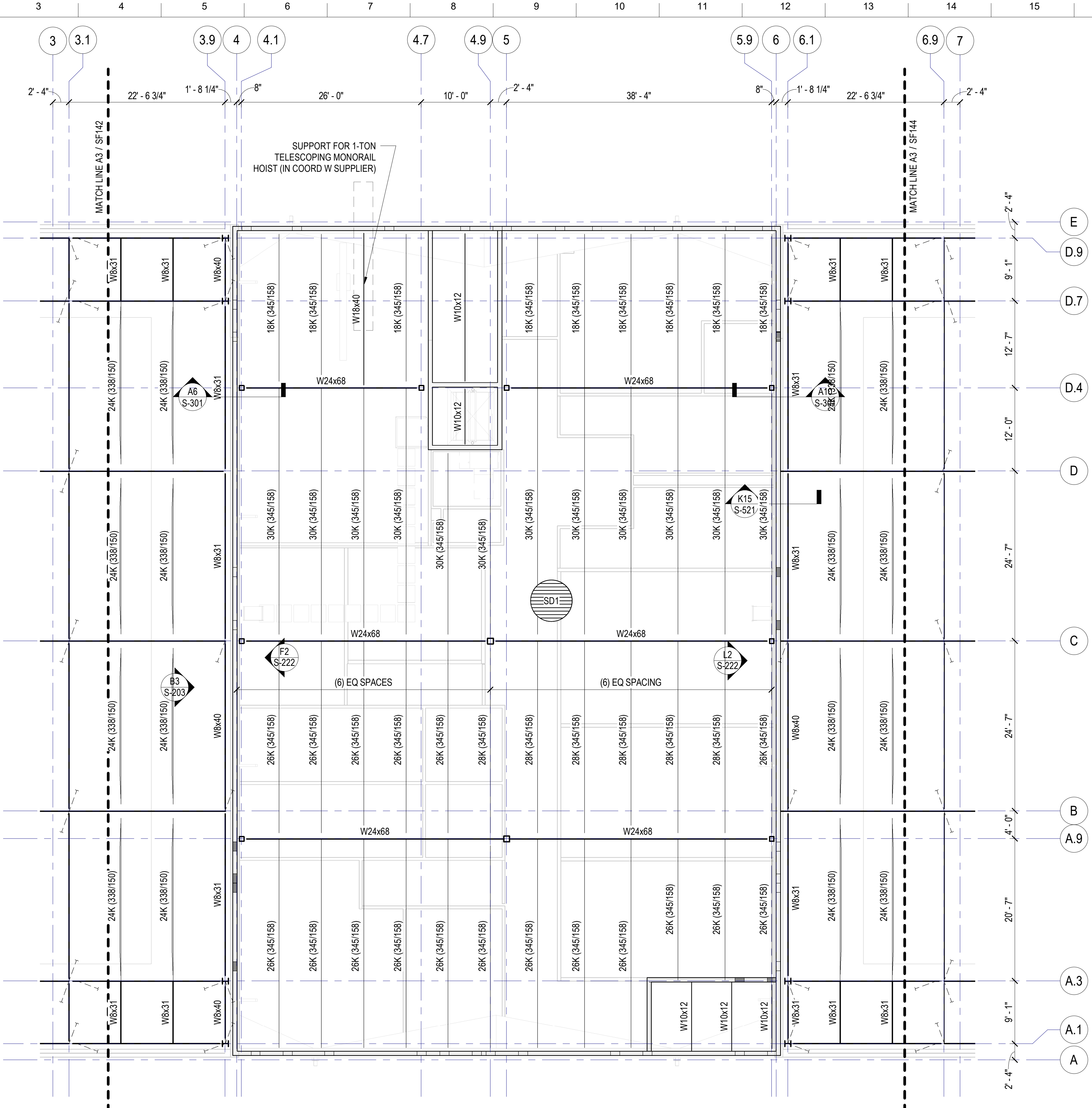

A3 ROOF FRAMING PLAN - AREA C
SCALE: 1/8" = 1'-0"



ROOF FRAMING NOTES

- CONTRACTOR IS RESPONSIBLE FOR THE CONSTRUCTION SEQUENCE FOR ALL STRUCTURAL ELEMENTS IN THE PROJECT. CONTRACTOR IS RESPONSIBLE TO PROVIDE ANY SHORING OR BRACING AS NEEDED UNTIL STRUCTURE IS COMPLETE.
- ALL BEAM-TO-COLUMN CONNECTIONS SHALL BE SINGLE SHEAR TAB CONNECTIONS UNLESS NOTED OTHERWISE. SEE TYPICAL STEEL-TO-STEEL CONNECTION SCHEDULE.
- SHOP DRAWINGS MUST BE PRODUCED FOR ALL JOISTS AND SHALL BE SUBMITTED TO THE ENGINEER FOR APPROVAL PRIOR TO FABRICATION. CALCULATIONS SHALL BE SUBMITTED WITH THE SHOP DRAWINGS AND SHALL BEAR THE STAMP OF A LICENSED ENGINEER.
- OPEN WEB STEEL JOISTS SHALL BE DESIGNED BY THE MANUFACTURER TO SUPPORT THE MECHANICAL, AXIAL (WL/EQ), LATERAL, POINT, AND UNIFORM LOADS SHOWN ON PLANS AND IN DETAILS. LOADS SHOWN ARE ASD MAGNITUDE LOADS UNLESS NOTED OTHERWISE.
- THE STEEL JOIST SUPPLIER IS RESPONSIBLE IN DESIGNING ALL JOISTS, INCLUDING SLOPE, CAMBER, BEARING ENDS, ETC. ALL DESIGNS SHALL BE IN ACCORDANCE WITH SJI SPECIFICATIONS WITH A MAXIMUM DEFLECTION OF JOISTS OF TL/180 AND LL/240.
- HORIZONTAL AND CROSS BRIDGING SHALL BE SIZED, LOCATED, AND SUPPLIED BY THE JOIST MANUFACTURER.
- ALL STABILIZER PLATES SHALL BE 6"x6"xCHORD GAP-1/4" WITH A 3/4" DIAMETER HOLE, AND MUST EXTEND 3" MINIMUM BELOW THE BOTTOM CHORD.
- ALL CONCENTRATED LOADS GREATER THAN 100 POUNDS SUPPORTED BY OPEN WEB JOISTS SHALL BE LOCATED WITHIN 6" OF PANEL POINT. OTHERWISE, JOIST SHALL BE REINFORCED WITH AN ADDITIONAL WEB MEMBER. (RE: H1/S-511)
- BOTTOM CHORD OF ANY JOIST SHALL NOT BE USED TO BRACE ANY MISC EQUIPMENT.
- JOIST BRIDGING SHALL NEVER BE USED TO SUPPORT HANGING LOADS.
- JOIST LOADS SHOWN ON PLAN WITH THE JOIST DESIGNATION "K (XX/XX)" ACCOUNTS FOR TOTAL LOAD/LIVE LOAD (ASD).
- OPEN WEB STEEL JOISTS SHALL BE DESIGNED FOR A NET UPLIFT DUE TO WIND LOADING. RE: SHEET S-005.
- STEEL JOISTS SHALL BE DESIGNED FOR AN ADDITIONAL VERT LIVE LOAD (ASD) OF +/-500# AT EACH PANEL POINT
- STANDARD JOIST SEAT DEPTH SHALL BE 2 1/2". CONTRACTOR TO COORDINATE TOP OF GIRDERS USING 2 1/2" JOIST SEAT DEPTH UNO.
- CONTRACTOR TO COORDINATE ALL ROOF EDGES AND OPENINGS. OPENINGS LESS THAN 6" IN ALL DIRECTIONS ARE NOT SHOWN IN STRUCTURAL DRAWINGS. RE: L-1-L17/S-511 FOR PLACEMENT CRITERIA.
- RE: SHEETS S-001 - S-005 FOR GENERAL NOTES AND DESIGN CRITERIA.
- RE: SHEETS S-511 - S-513 FOR TYPICAL ROOF FRAMING DETAILS.
- RE: SHEETS S-601 - S-602 FOR SCHEDULES.

KEYNOTES

- HANGING FAN ON BOTTOM CHORD OF TRUSS ON GRID D. APPROXIMATE WEIGHT OF 300LBS (DL ASD). RE: ARCH/MEP FOR EXACT LOCATION. RE: MFR FOR ATTACHMENT
- PROVIDE L4x4x1/4 BRACING AT THIRD POINTS OF BEAM
- PROVIDE L8x8x1/2 BRACING AT THIRD POINTS OF BEAM
- PROVIDE L8x8x1/2 BRACING AT BEAM HALF POINT
- SUPPORT FRAMING FOR 1-TON MONORAIL HOIST CRANE

CRANE COORDINATION AND LATERAL BRACING IN PROGRESS

KEY PLAN

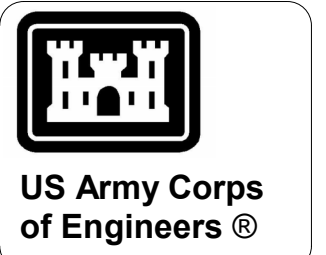
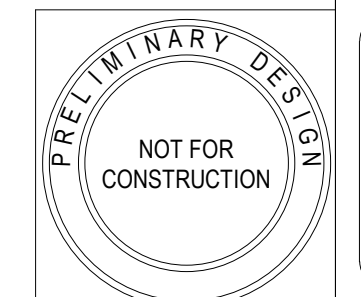
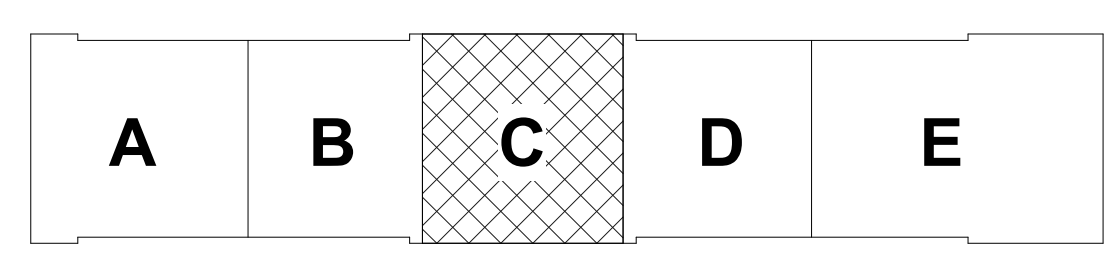

MARK	DESCRIPTION	DATE

DESIGNED BY: A. VALENCIA	ISSUE DATE: NOVEMBER 13, 2025
DRAWN BY: R. CARLSON	SUBMITTAL NO.: WB12PL25RA0012
CHECKED BY: D. CLAYSON	CONTRACT NO.:
SUBMITTED BY: P. PASZCZUK	CONTRACT NO.:
SIZE: ANSI D	

US ARMY CORPS OF ENGINEERS
LOS ANGELES DISTRICT

KORTE CONSTRUCTION
5700 OAKLAND AVE. SUITE 275
ST. LOUIS, MO 63110

CREECH AIR FORCE BASE, CLARK COUNTY, NV
DISASTER RESILIENCY PROGRAM (DRP) - PHASE 2
494137

ROOF FRAMING PLAN - AREA C

SHEET ID
SF143

DP-1 95% SUBMISSION

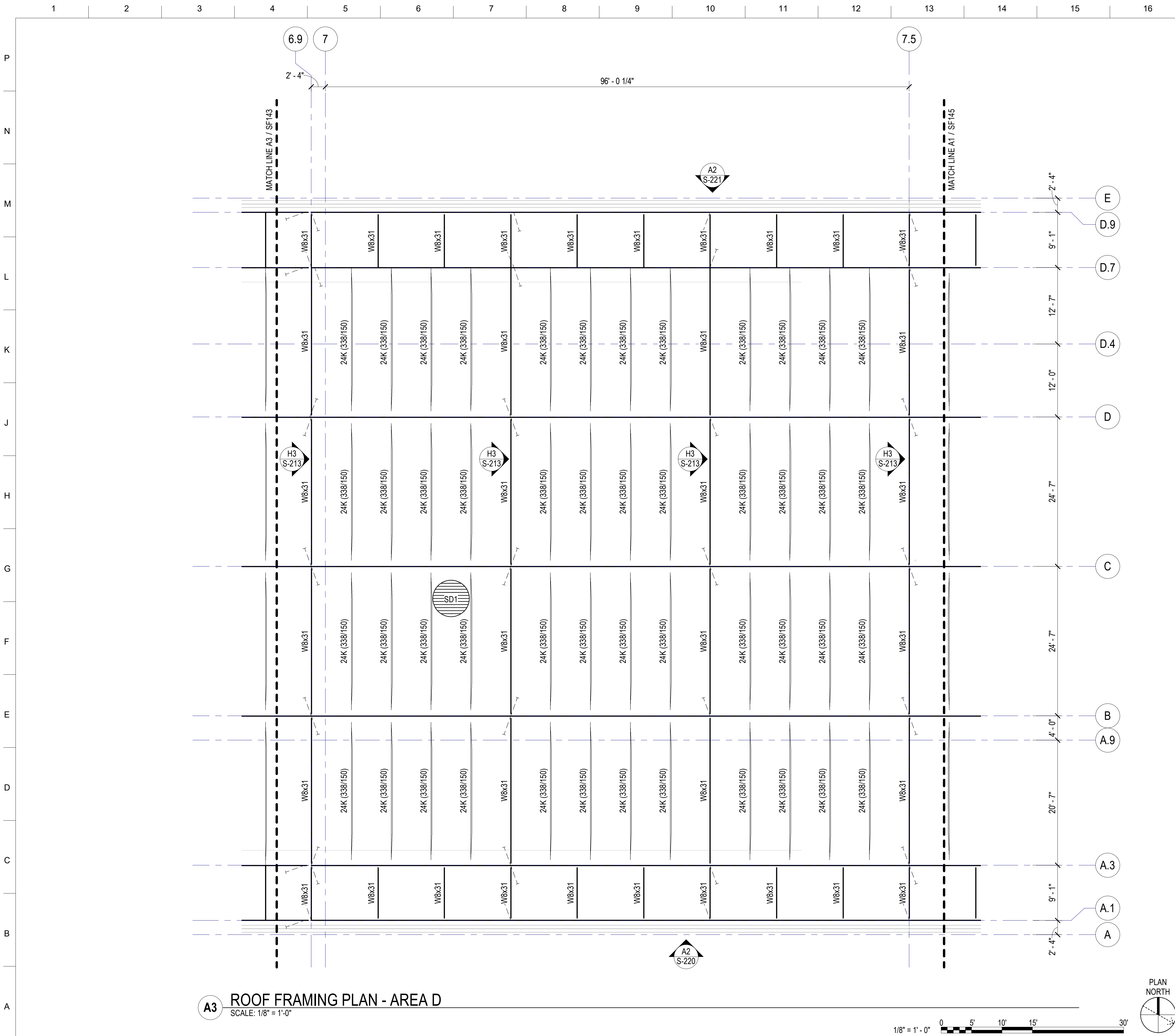

A3 ROOF FRAMING PLAN - AREA D
SCALE: 1/8" = 1'-0"

ROOF FRAMING NOTES

1. CONTRACTOR IS RESPONSIBLE FOR THE CONSTRUCTION SEQUENCE FOR ALL STRUCTURAL ELEMENTS IN THE PROJECT. CONTRACTOR IS RESPONSIBLE TO PROVIDE ANY SHORING OR BRACING AS NEEDED UNTIL STRUCTURE IS COMPLETE.
2. ALL BEAM-TO-COLUMN CONNECTIONS SHALL BE SINGLE SHEAR TAB CONNECTIONS UNLESS NOTED OTHERWISE. SEE TYPICAL STEEL-TO-STEEL CONNECTION SCHEDULE.
3. SHOP DRAWINGS MUST BE PRODUCED FOR ALL JOISTS AND SHALL BE SUBMITTED TO THE ENGINEER FOR APPROVAL PRIOR TO FABRICATION. CALCULATIONS SHALL BE SUBMITTED WITH THE SHOP DRAWINGS AND SHALL BEAR THE STAMP OF A LICENSED ENGINEER.
4. OPEN WEB STEEL JOISTS SHALL BE DESIGNED BY THE MANUFACTURER TO SUPPORT THE MECHANICAL, AXIAL (WL/EQ), LATERAL, POINT, AND UNIFORM LOADS SHOWN ON PLANS AND IN DETAILS. LOADS SHOWN ARE ASD MAGNITUDE LOADS UNLESS NOTED OTHERWISE.
5. THE STEEL JOIST SUPPLIER IS RESPONSIBLE IN DESIGNING ALL JOISTS, INCLUDING SLOPE, CAMBER, BEARING ENDS, ETC. ALL DESIGNS SHALL BE IN ACCORDANCE WITH SJI SPECIFICATIONS WITH A MAXIMUM DEFLECTION OF JOISTS OF TL/180 AND LL/240.
6. HORIZONTAL AND CROSS BRIDGING SHALL BE SIZED, LOCATED, AND SUPPLIED BY THE JOIST MANUFACTURER.
7. ALL STABILIZER PLATES SHALL BE 6"x6"xCHORD GAP-1/4" WITH A 3/4" DIAMETER HOLE, AND MUST EXTEND 3" MINIMUM BELOW THE BOTTOM CHORD.
8. ALL CONCENTRATED LOADS GREATER THAN 100 POUNDS SUPPORTED BY OPEN WEB JOISTS SHALL BE LOCATED WITHIN 6" OF PANEL POINT. OTHERWISE, JOIST SHALL BE REINFORCED WITH AN ADDITIONAL WEB MEMBER. (RE: H1/S-511)
9. BOTTOM CHORD OF ANY JOIST SHALL NOT BE USED TO BRACE ANY MISC EQUIPMENT.
10. JOIST BRIDGING SHALL NEVER BE USED TO SUPPORT HANGING LOADS.
11. JOIST LOADS SHOWN ON PLAN WITH THE JOIST DESIGNATION "K (XX/XX)" ACCOUNTS FOR TOTAL LOAD/LIVE LOAD (ASD).
12. OPEN WEB STEEL JOISTS SHALL BE DESIGNED FOR A NET UPLIFT DUE TO WIND LOADING, RE: SHEET S-005.
13. STEEL JOISTS SHALL BE DESIGNED FOR AN ADDITIONAL VERT LIVE LOAD (ASD) OF +/-500# AT EACH PANEL POINT
14. STANDARD JOIST SEAT DEPTH SHALL BE 2 1/2". CONTRACTOR TO COORDINATE TOP OF GIRDERS USING 2 1/2" JOIST SEAT DEPTH UNO.
15. CONTRACTOR TO COORDINATE ALL ROOF EDGES AND OPENINGS. OPENINGS LESS THAN 6" IN ALL DIRECTIONS ARE NOT SHOWN IN STRUCTURAL DRAWINGS. RE: L1-L17/S-511 FOR PLACEMENT CRITERIA.
16. RE: SHEETS S-001 - S-005 FOR GENERAL NOTES AND DESIGN CRITERIA.
17. RE: SHEETS S-511 - S-513 FOR TYPICAL ROOF FRAMING DETAILS.
18. RE: SHEETS S-601 - S-602 FOR SCHEDULES.

KEYNOTES

- 1 HANGING FAN ON BOTTOM CHORD OF TRUSS ON GRID D. APPROXIMATE WEIGHT OF 300LBS (DL ASD). RE: ARCH/MEP FOR EXACT LOCATION. RE: MFR FOR ATTACHMENT
- 2 PROVIDE L4x4x1/4 BRACING AT THIRD POINTS OF BEAM
- 3 PROVIDE L8x8x1/2 BRACING AT THIRD POINTS OF BEAM
- 4 PROVIDE L8x8x1/2 BRACING AT BEAM HALF POINT
- 5 SUPPORT FRAMING FOR 1-TON MONORAIL HOIST CRANE

CRANE COORDINATION AND LATERAL BRACING IN PROGRESS

KEY PLAN

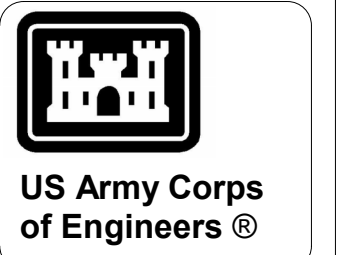
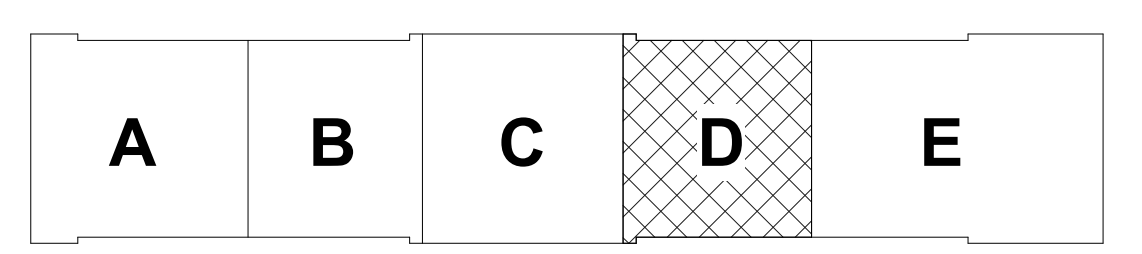

MARK	DESCRIPTION	DATE

DESIGNED BY: A. VALENCIA	ISSUE DATE: NOVEMBER 13, 2025
DRAWN BY: R. CARLSON	SOLICITATION NO.: W812PL25RA0012
CHECKED BY: D. CLAYSON	CONTRACT NO.: W812PL25C0037
SUBMITTED BY: P. PASZCZUK	SIZE: ANSI D

US ARMY CORPS OF ENGINEERS
LOS ANGELES DISTRICT

KORTE CONSTRUCTION
5700 OAKLAND AVE. SUITE 275
ST. LOUIS, MO 63110

CREECH AIR FORCE BASE, CLARK COUNTY, NV
DISASTER RESILIENCY PROGRAM (DRP) - PHASE 2
494137

ROOF FRAMING PLAN - AREA D

SHEET ID
SF144

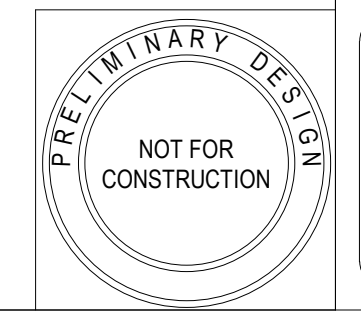

DP-1 95% SUBMISSION

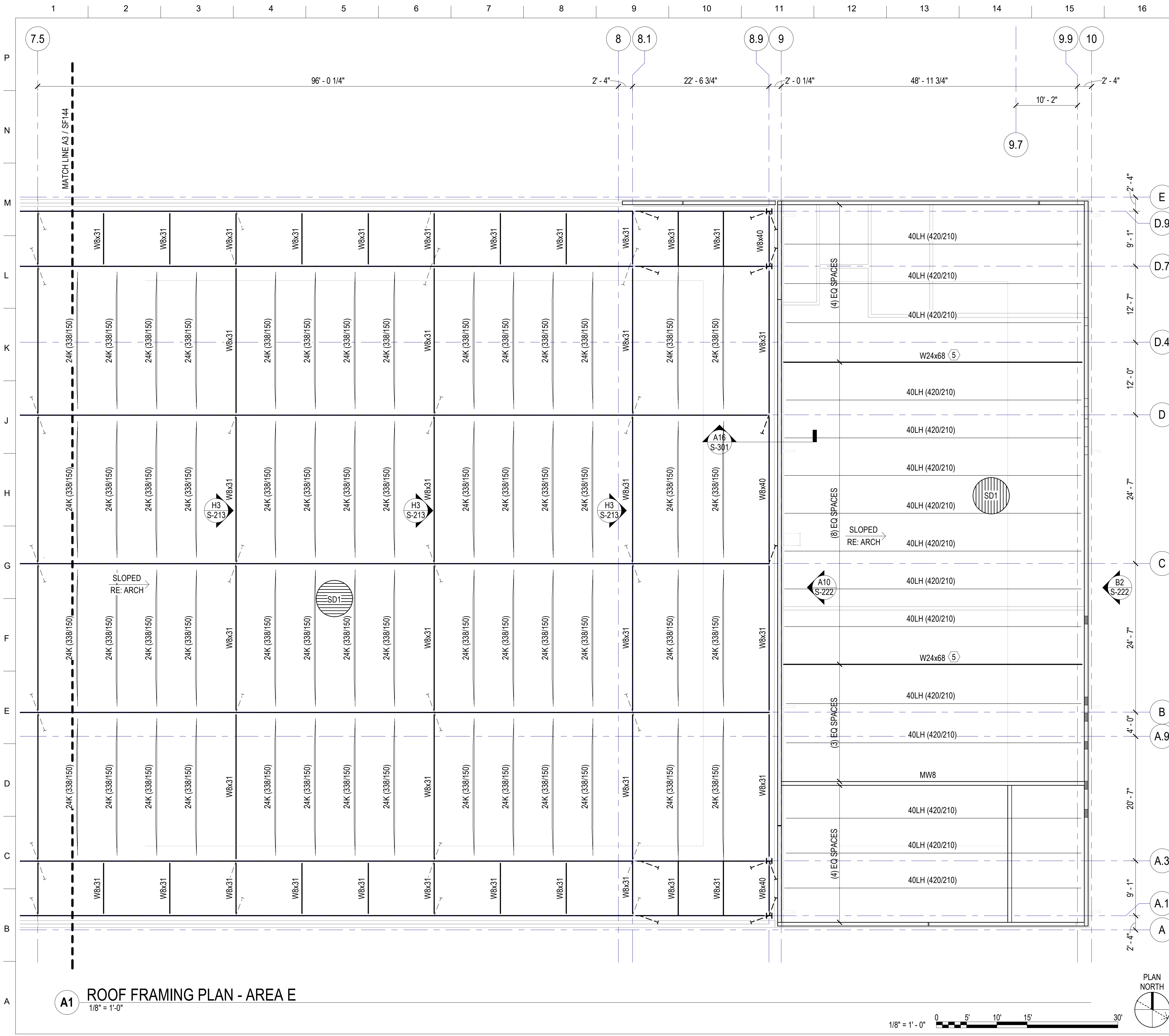

ROOF FRAMING NOTES

- 1. CONTRACTOR IS RESPONSIBLE FOR THE CONSTRUCTION SEQUENCE FOR ALL STRUCTURAL ELEMENTS IN THE PROJECT. CONTRACTOR IS RESPONSIBLE TO PROVIDE ANY SHORING OR BRACING AS NEEDED UNTIL STRUCTURE IS COMPLETE.
2. ALL BEAM-TO-COLUMN CONNECTIONS SHALL BE SINGLE SHEAR TAB CONNECTIONS UNLESS NOTED OTHERWISE. SEE TYPICAL STEEL-TO-STEEL CONNECTION SCHEDULE.
3. SHOP DRAWINGS MUST BE PRODUCED FOR ALL JOISTS AND SHALL BE SUBMITTED TO THE ENGINEER FOR APPROVAL PRIOR TO FABRICATION. CALCULATIONS SHALL BE SUBMITTED WITH THE SHOP DRAWINGS AND SHALL BEAR THE STAMP OF A LICENSED ENGINEER.
4. OPEN WEB STEEL JOISTS SHALL BE DESIGNED BY THE MANUFACTURER TO SUPPORT THE MECHANICAL, AXIAL (WL/EQ), LATERAL, POINT, AND UNIFORM LOADS SHOWN ON PLANS AND IN DETAILS. LOADS SHOWN ARE ASD MAGNITUDE LOADS UNLESS NOTED OTHERWISE.
5. THE STEEL JOIST SUPPLIER IS RESPONSIBLE IN DESIGNING ALL JOISTS, INCLUDING SLOPE, CAMBER, BEARING ENDS, ETC. ALL DESIGNS SHALL BE IN ACCORDANCE WITH SJI SPECIFICATIONS WITH A MAXIMUM DEFLECTION OF JOISTS OF TL/180 AND LL/240.
6. HORIZONTAL AND CROSS BRIDGING SHALL BE SIZED, LOCATED, AND SUPPLIED BY THE JOIST MANUFACTURER.
7. ALL STABILIZER PLATES SHALL BE 6"x6"xCHORD GAP-1/4" WITH A 3/4" DIAMETER HOLE, AND MUST EXTEND 3" MINIMUM BELOW THE BOTTOM CHORD.
8. ALL CONCENTRATED LOADS GREATER THAN 100 POUNDS SUPPORTED BY OPEN WEB JOISTS SHALL BE LOCATED WITHIN 6" OF PANEL POINT. OTHERWISE, JOIST SHALL BE REINFORCED WITH AN ADDITIONAL WEB MEMBER. (RE: H1/S-511)
9. BOTTOM CHORD OF ANY JOIST SHALL NOT BE USED TO BRACE ANY MISC EQUIPMENT.
10. JOIST BRIDGING SHALL NEVER BE USED TO SUPPORT HANGING LOADS.
11. JOIST LOADS SHOWN ON PLAN WITH THE JOIST DESIGNATION "K (XX/XX)" ACCOUNTS FOR TOTAL LOAD/LIVE LOAD (ASD).
12. OPEN WEB STEEL JOISTS SHALL BE DESIGNED FOR A NET UPLIFT DUE TO WIND LOADING, RE: SHEET S-005.
13. STEEL JOISTS SHALL BE DESIGNED FOR AN ADDITIONAL VERT LIVE LOAD (ASD) OF +/-500# AT EACH PANEL POINT
14. STANDARD JOIST SEAT DEPTH SHALL BE 2 1/2". CONTRACTOR TO COORDINATE TOP OF GIRDERS USING 2 1/2" JOIST SEAT DEPTH UNO.
15. CONTRACTOR TO COORDINATE ALL ROOF EDGES AND OPENINGS. OPENINGS LESS THAN 6" IN ALL DIRECTIONS ARE NOT SHOWN IN STRUCTURAL DRAWINGS. RE: L1-L17/S-511 FOR PLACEMENT CRITERIA.
16. RE: SHEETS S-001 - S-005 FOR GENERAL NOTES AND DESIGN CRITERIA.
17. RE: SHEETS S-511 - S-513 FOR TYPICAL ROOF FRAMING DETAILS.
18. RE: SHEETS S-601 - S-602 FOR SCHEDULES.

KEYNOTES

- 1 HANGING FAN ON BOTTOM CHORD OF TRUSS ON GRID D. APPROXIMATE WEIGHT OF 300LBS (DL ASD). RE: ARCH/MEP FOR EXACT LOCATION. RE: MFR FOR ATTACHMENT
2 PROVIDE L4x4x1/4 BRACING AT THIRD POINTS OF BEAM
3 PROVIDE L8x8x1/2 BRACING AT THIRD POINTS OF BEAM
4 PROVIDE L8x8x1/2 BRACING AT BEAM HALF POINT
5 SUPPORT FRAMING FOR 1-TON MONORAIL HOIST CRANE

CRANE COORDINATION AND LATERAL BRACING IN PROGRESS

KEY PLAN

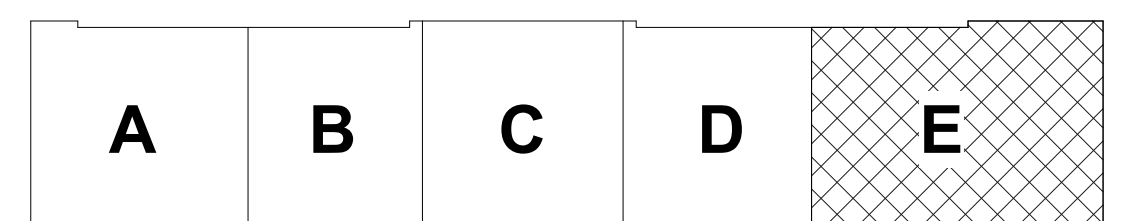

A1 ROOF FRAMING PLAN - AREA E
1/8" = 1'-0"

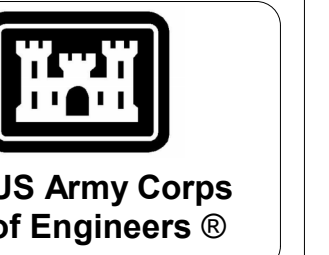
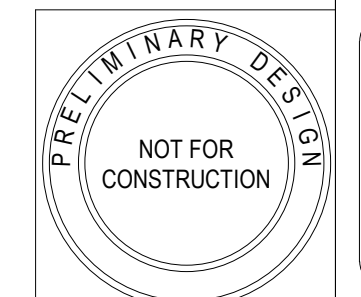
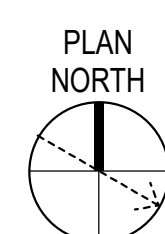

Table with columns: MARK, DESCRIPTION, DATE. It is currently empty.

Table with columns: DESIGNED BY, DRAWN BY, CHECKED BY, SUBMITTED BY, SIZE, ANS/D. Includes names like A. VALENCIA, R. CARLSON, D. CLAYSON, P. PASZCZUK.

US ARMY CORPS OF ENGINEERS
LOS ANGELES DISTRICT
KORTE CONSTRUCTION
5700 OAKLAND AVE. SUITE 275
ST. LOUIS, MO 63110

CREECH AIR FORCE BASE, CLARK COUNTY, NV
DISASTER RESILIENCY PROGRAM (DRP) - PHASE 2
494137
ROOF FRAMING PLAN - AREA E

SHEET ID
SF145
DP-1 95% SUBMISSION

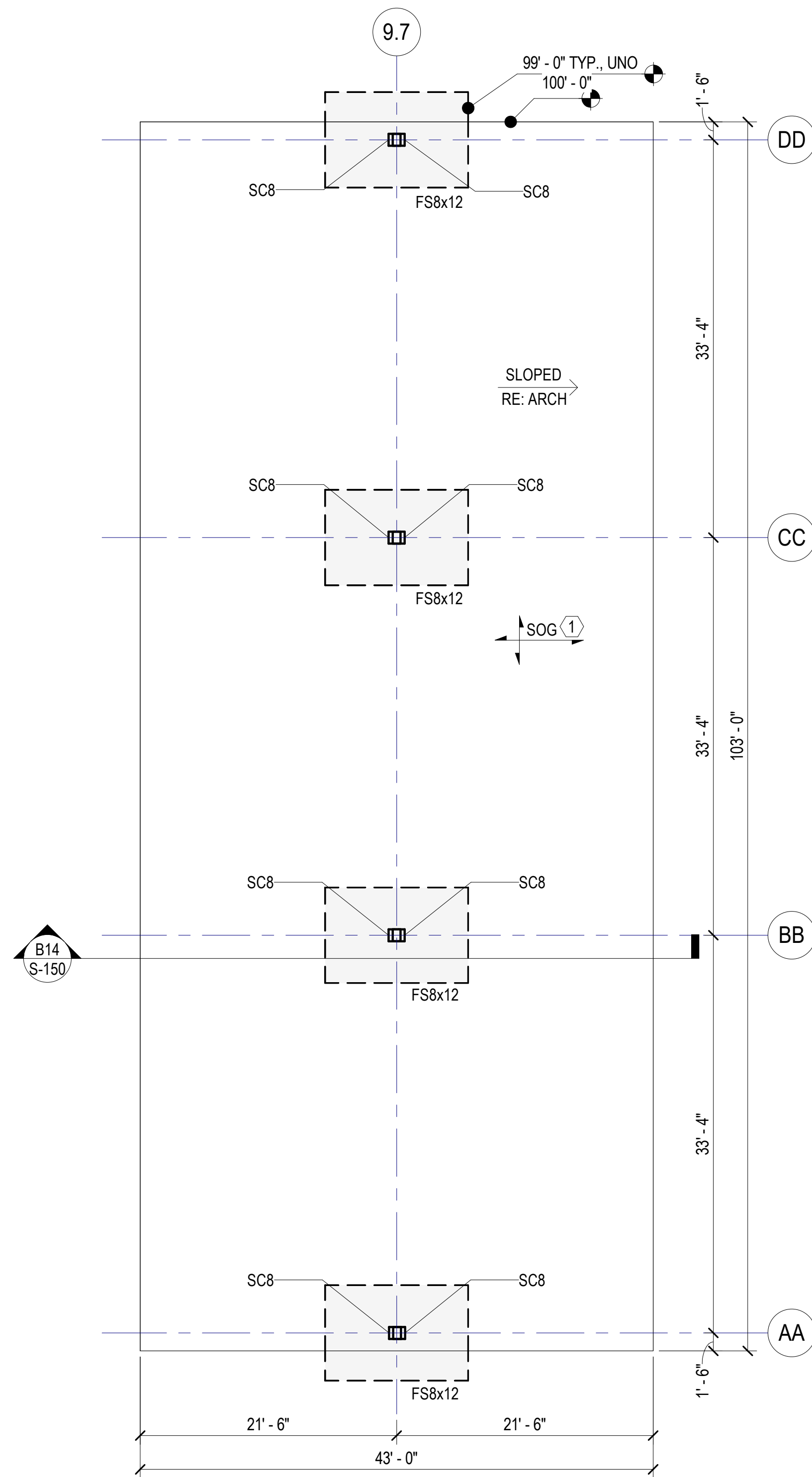

B3 AGE STORAGE FOUNDATION PLAN
1/8" = 1'-0" REF: S-201

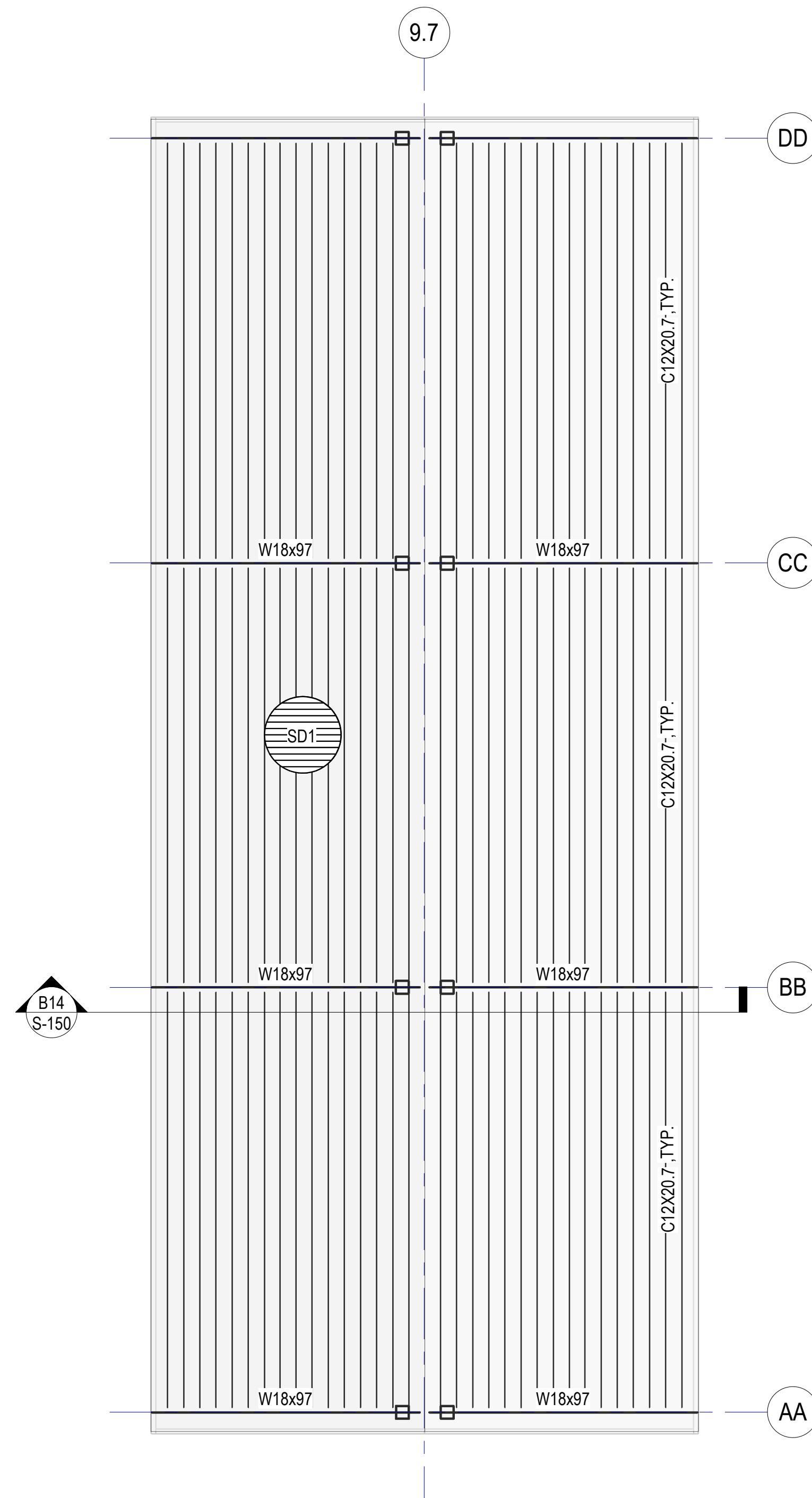

B8 AGE STORAGE ROOF FRAMING PLAN
1/8" = 1'-0" REF: S-301

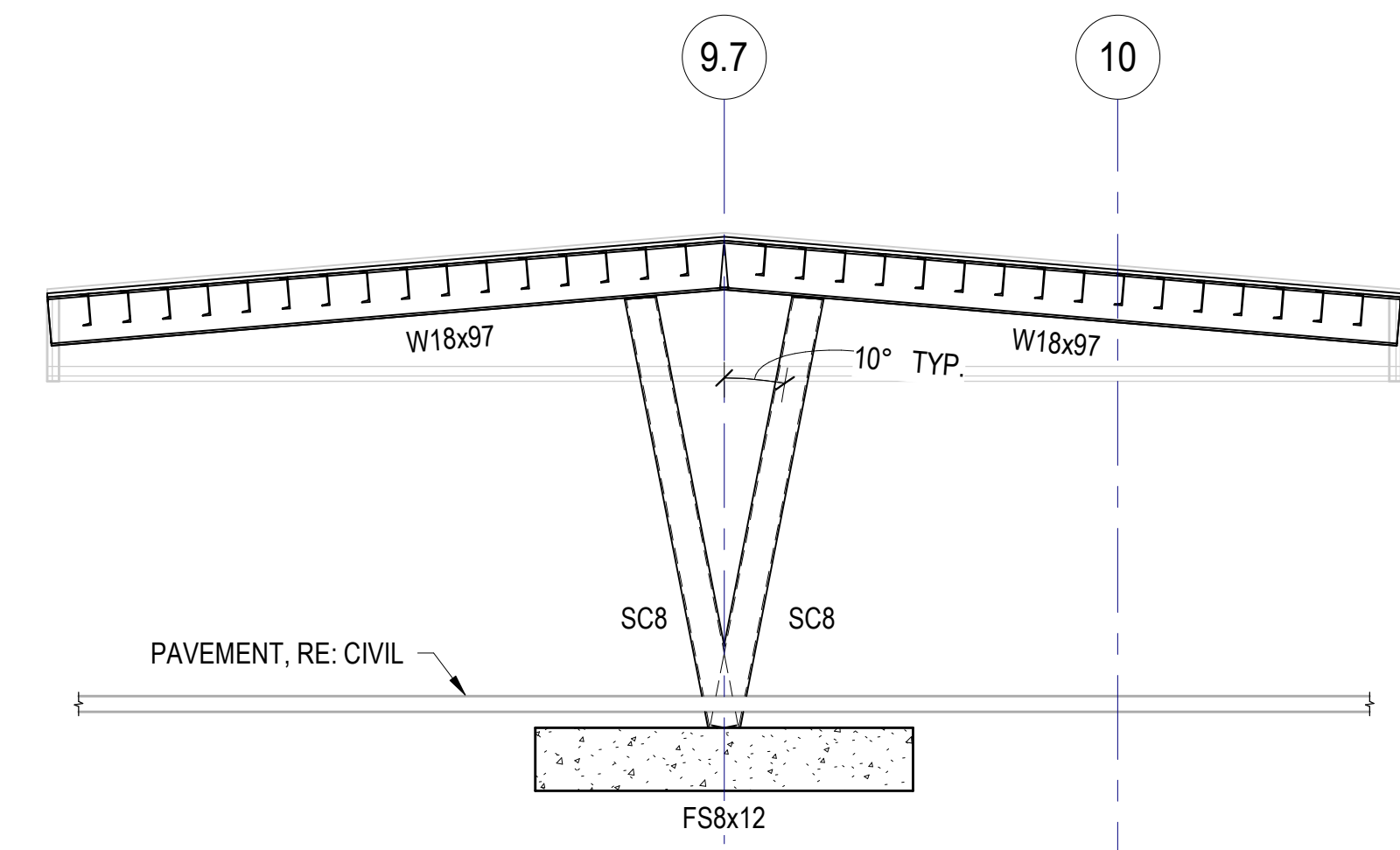

B14 AGE STORAGE ELEVATION
3/16" = 1'-0" REF: S-150

CONNECTION
DETAILS IN
PROGRESS

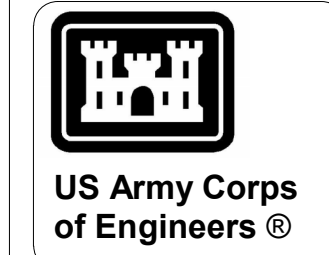
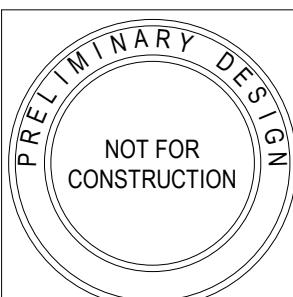
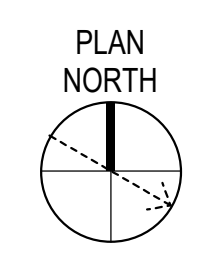

MARK	DESCRIPTION	DATE

DESIGNED BY: A. VALENCIA	ISSUE DATE: NOVEMBER 13, 2025
DRAWN BY: R. CARLSON	SOLICITATION NO.: W812PL25RA0012
CHECKED BY: D. CLAYSON	CONTRACT NO.: W812PL25C0037
SUBMITTED BY: P. PASZCZUK	SIZE: ANSI D

US ARMY CORPS OF ENGINEERS
LOS ANGELES DISTRICT

KORTE CONSTRUCTION
5700 OAKLAND AVE. SUITE 275
ST. LOUIS, MO 63110

CREECH AIR FORCE BASE, CLARK COUNTY, NV
DISASTER RESILIENCY PROGRAM (DRP) - PHASE 2
494137
AGE STORAGE PLAN & ELEVATION

SHEET ID
S-150

BRACED FRAME GUSSET PLATE CONNECTION, RE: SCHEDULE ON S-602

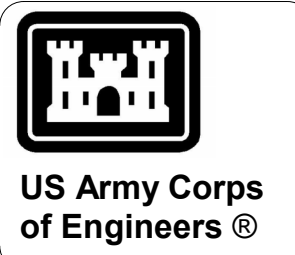

US Army Corps of Engineers®

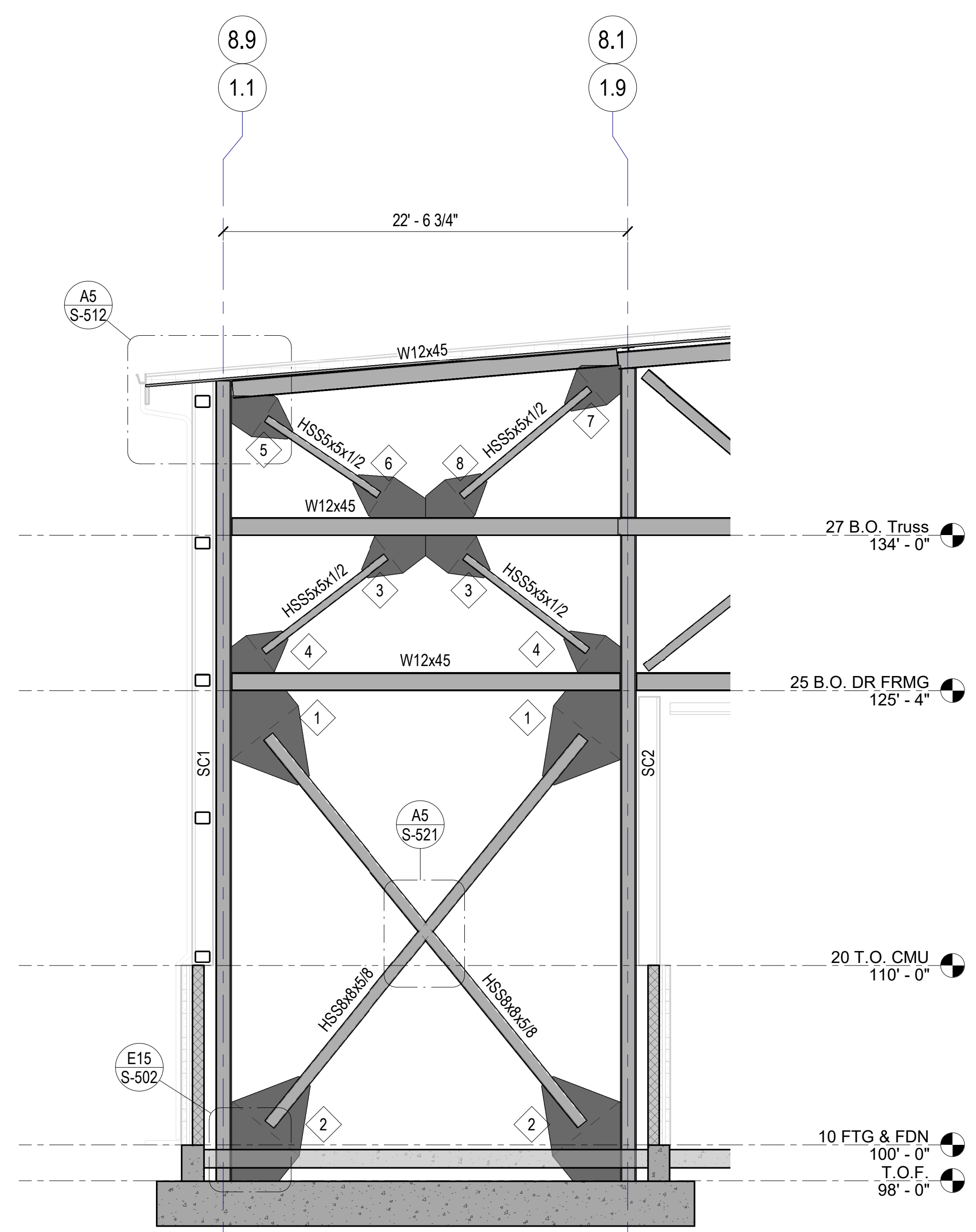

D6 BRACED FRAME - GRIDS A.1, D.9
3/16" = 1'-0" REF: SB101

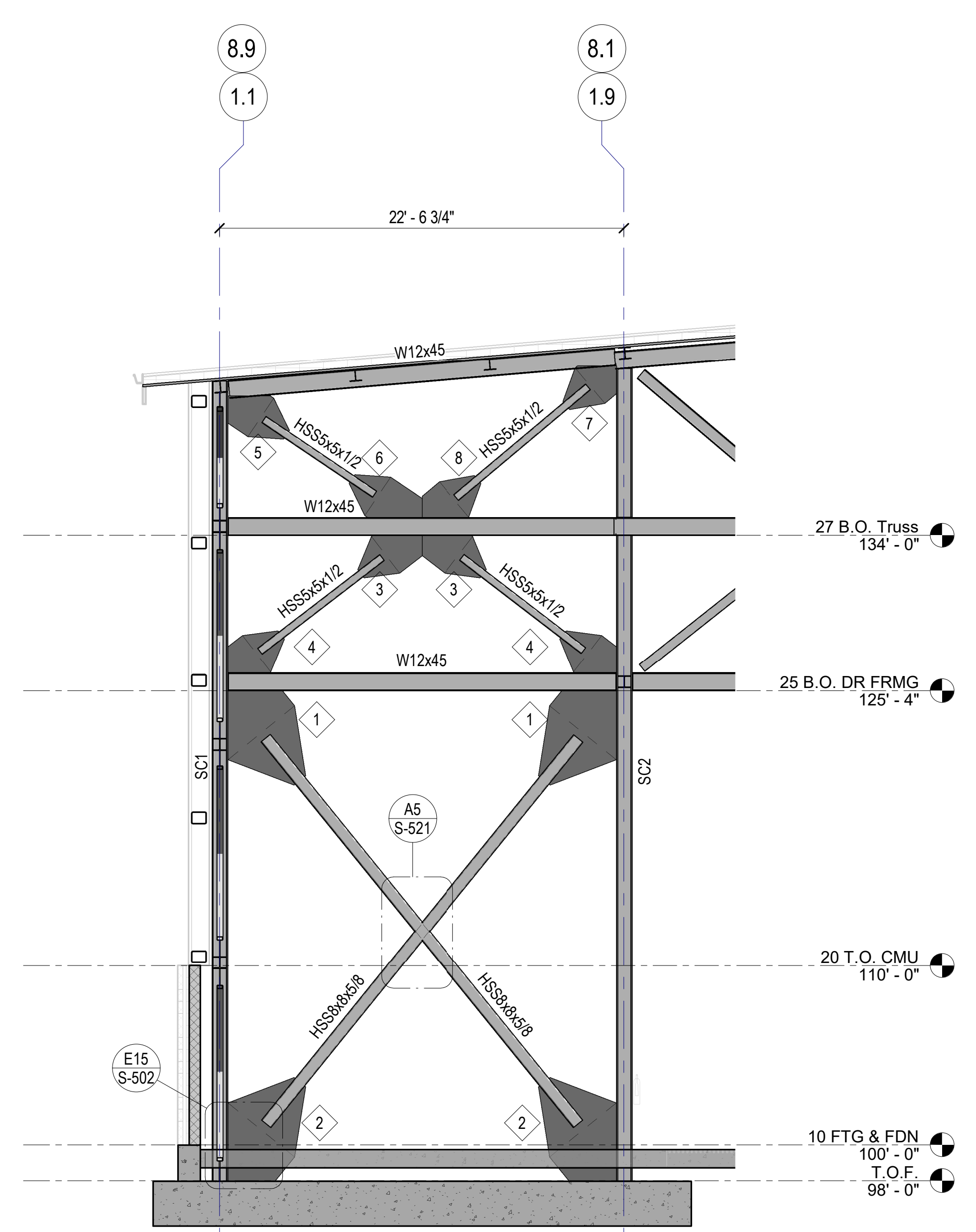

D14 BRACED FRAME - GRIDS A.3, D.7
3/16" = 1'-0" REF: SB101

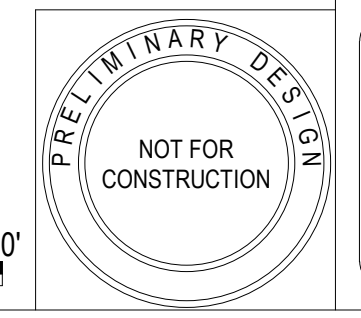
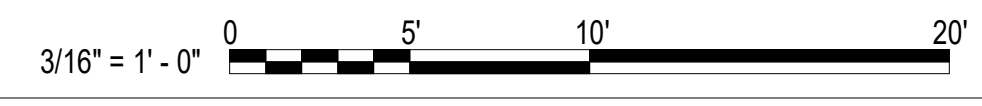

MARK	DESCRIPTION	DATE

DESIGNED BY: A. VALENCIA	ISSUE DATE: NOVEMBER 13, 2025
DRAWN BY: R. CARLSON	SOLICITATION NO.: W812PL25RA0012
CHECKED BY: D. CLAYSON	CONTRACT NO.: W812PL25C0037
SUBMITTED BY: P. PASZCZUK	
SIZE: ANSI D	

US ARMY CORPS OF ENGINEERS
LOS ANGELES DISTRICT

KORTE CONSTRUCTION
5700 OAKLAND AVE. SUITE 275
ST. LOUIS, MO 63110

CREECH AIR FORCE BASE, CLARK COUNTY, NV
DISASTER RESILIENCY PROGRAM (DRP) - PHASE 2
494137

BRACED FRAME ELEVATIONS

SHEET ID
S-201

BRACED FRAME GUSSET PLATE CONNECTION, RE: SCHEDULE ON S-602

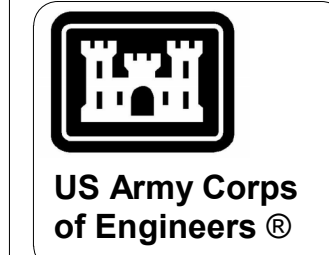

MARK	DESCRIPTION	DATE

DESIGNED BY: A. VALENCIA	ISSUE DATE: NOVEMBER 13, 2025
DRAWN BY: R. CARLSON	SOLICITATION NO.: W812PL25RA0012
CHECKED BY: D. CLAYSON	CONTRACT NO.: W812PL25C0037
SUBMITTED BY: P. PASZCZUK	SIZE: ANSI D

US ARMY CORPS OF ENGINEERS
LOS ANGELES DISTRICT
KORTE CONSTRUCTION
5700 OAKLAND AVE. SUITE 275
ST. LOUIS, MO 63110

CREECH AIR FORCE BASE, CLARK COUNTY, NV
DISASTER RESILIENCY PROGRAM (DRP) - PHASE 2
494137
BRACED FRAME ELEVATIONS

SHEET ID
S-202

P
N
M
L
K
J
H
G
F
E
D
C
B
A

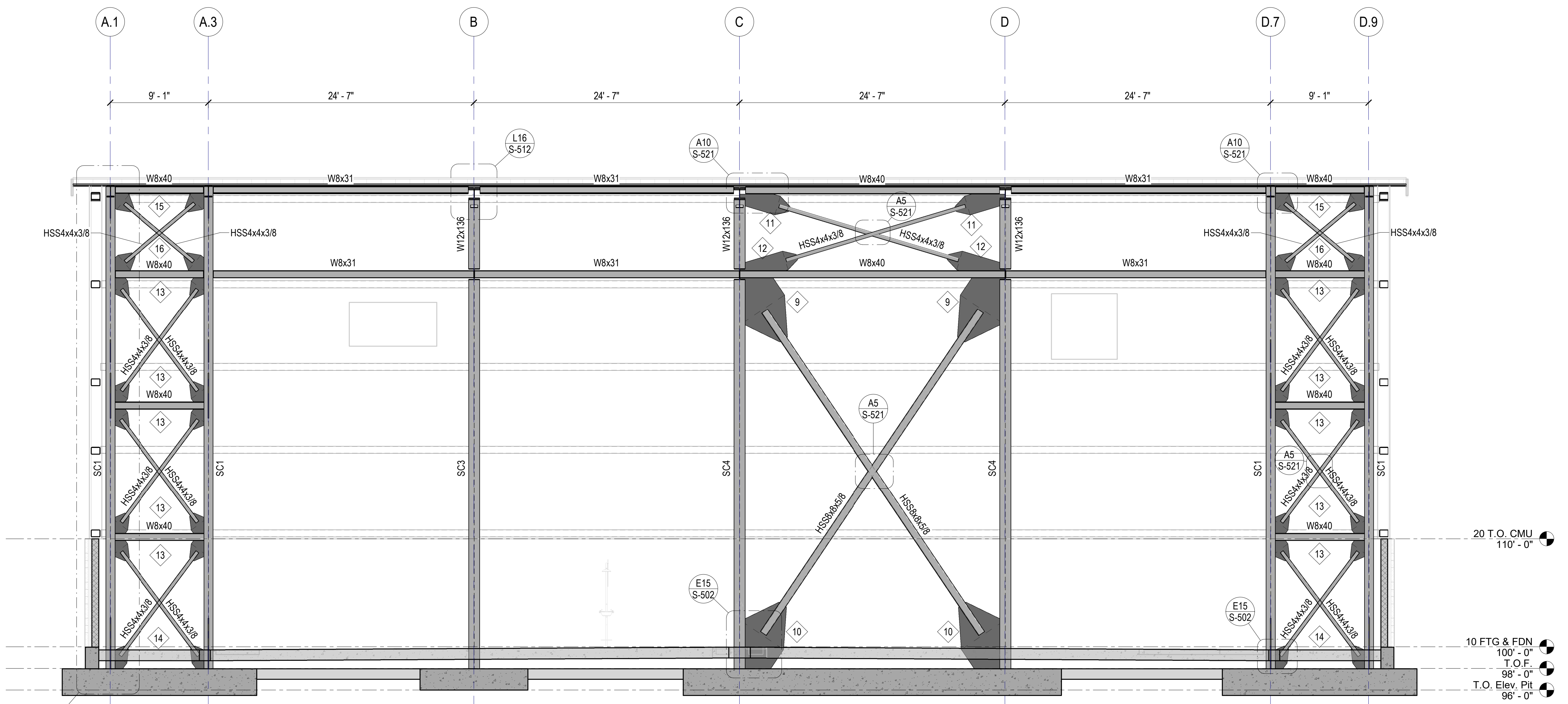

B2 BRACED FRAME ELEVATION - GRIDS 1.1, 8.9
3/16" = 1'-0" REF: SB101

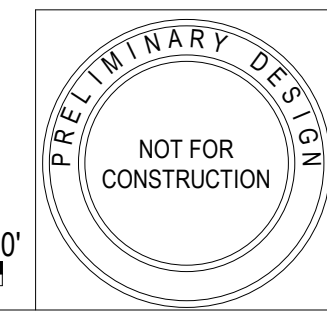
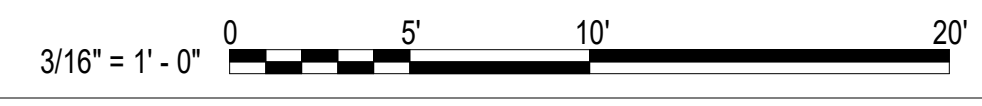

DP-1 95% SUBMISSION

BRACED FRAME GUSSET PLATE CONNECTION, RE: SCHEDULE ON S-602



US Army Corps of Engineers®

MARK	DESCRIPTION	DATE

DESIGNED BY: A. VALENCIA	ISSUE DATE: NOVEMBER 13, 2025
DRAWN BY: R. CARLSON	SOLICITATION NO.: W812PL25RA0012
CHECKED BY: D. CLAYSON	CONTRACT NO.: W812PL25C0037
SUBMITTED BY: P. PASZCZUK	SIZE: ANSI D

US ARMY CORPS OF ENGINEERS
LOS ANGELES DISTRICT
KORTE CONSTRUCTION
5700 OAKLAND AVE. SUITE 275
ST. LOUIS, MO 63110

CREECH AIR FORCE BASE, CLARK COUNTY, NV
DISASTER RESILIENCY PROGRAM (DRP) - PHASE 2
494137
BRACED FRAME ELEVATIONS

SHEET ID
S-203

DP-1 95% SUBMISSION

P
N
M
L
K
J
H
G
F
E
D
C
B
A

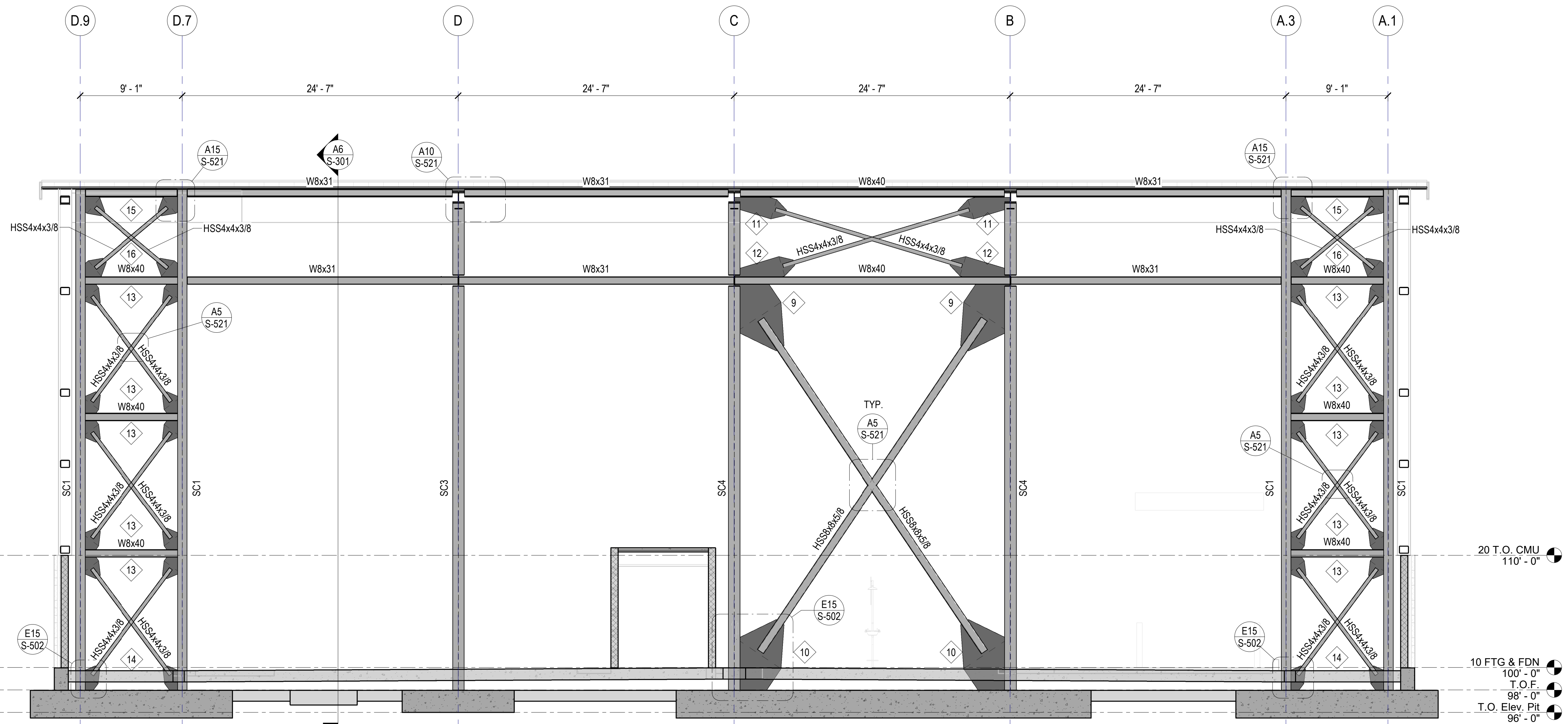

B3 BRACED FRAME ELEVATION - GRIDS 3.9, 6.1
3/16" = 1'-0" REF: SB103

3/16" = 1'-0" 0 5' 10' 20'

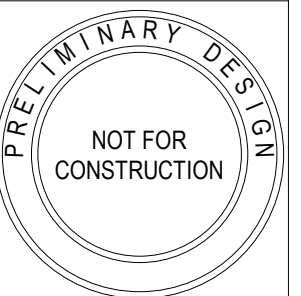

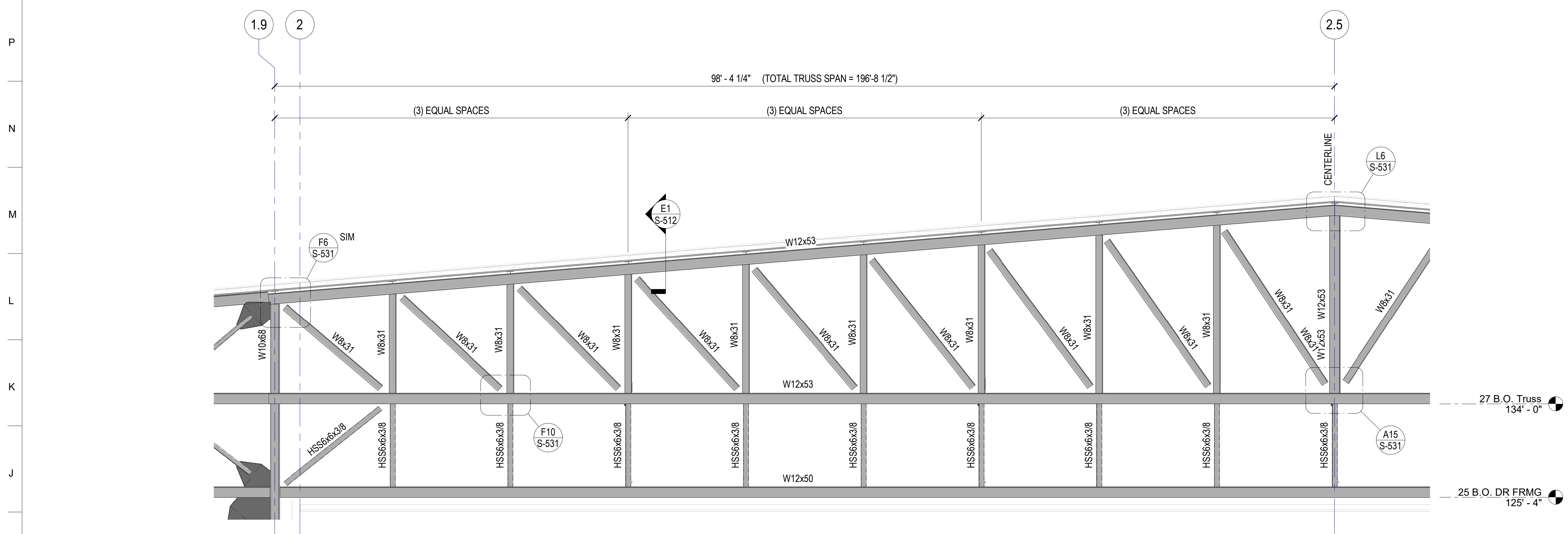

J2 GIRDER TRUSS TR-1 - GRIDS A.1 A.3 D.7 D.9 (WEST)
 3/16" = 1'-0" REF: SF131

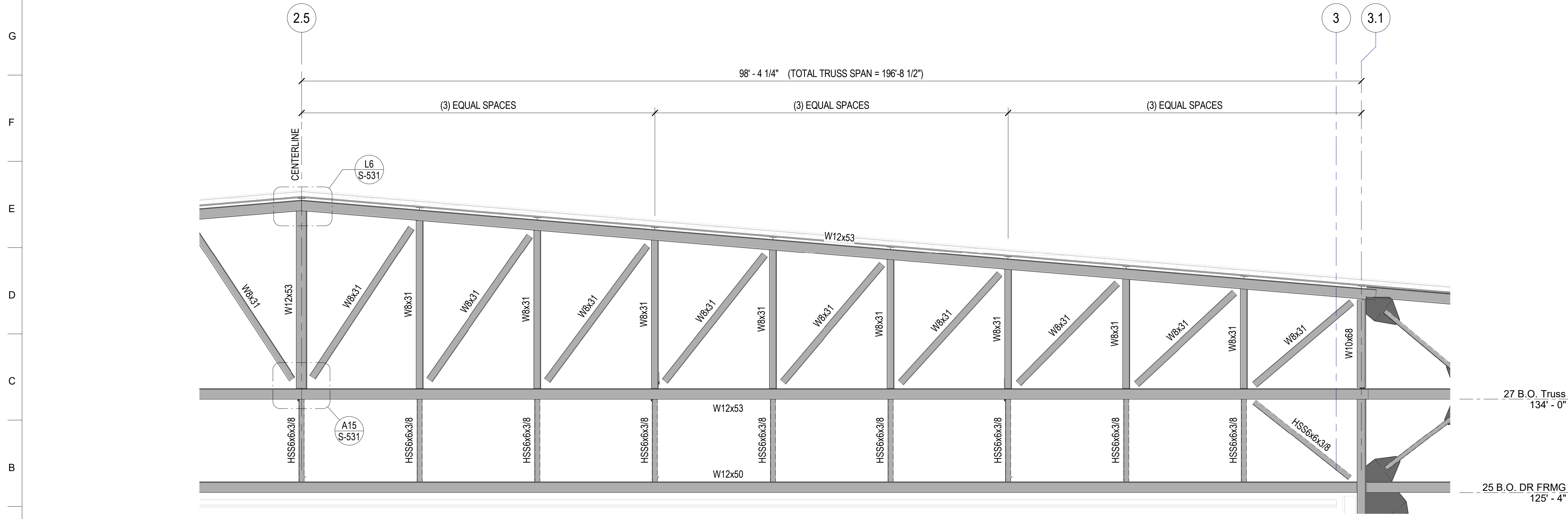

A2 GIRDER TRUSS TR-1 - GRIDS A.1 A.3 D.7 D.9 (EAST)
 3/16" = 1'-0" REF: SF131

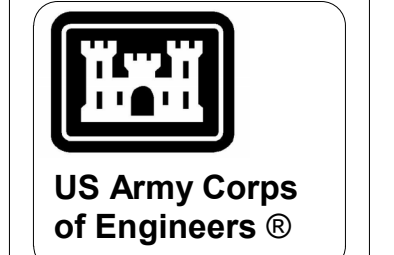
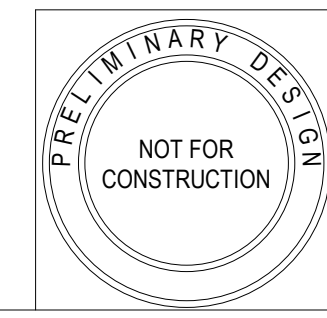
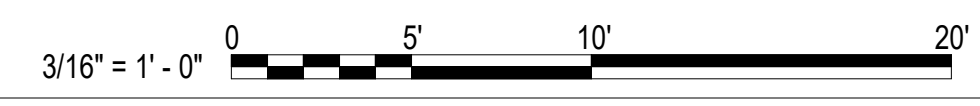

MARK	DESCRIPTION	DATE

ISSUE DATE: NOVEMBER 13, 2025	DESIGNED BY: A. VALENCIA
SOLICITATION NO.: W812PL25RA0012	DRAWN BY: R. CARLSON
CONTRACT NO.: W812PL25C0037	CHECKED BY: D. CLAYSON
	SUBMITTED BY: P. PASZCZUK
	SIZE: ANSI D

US ARMY CORPS OF ENGINEERS
 LOS ANGELES DISTRICT
 KORTE CONSTRUCTION
 5700 OAKLAND AVE. SUITE 275
 ST. LOUIS, MO 63110

CREECH AIR FORCE BASE, CLARK COUNTY, NV
 DISASTER RESILIENCY PROGRAM (DRP) - PHASE 2
 494137
 GIRDER TRUSS ELEVATIONS

SHEET ID
S-211

W12x53

W12x50

DP-1 95% SUBMISSION

P
N
M
L
K
J
H
G
F
E
D
C
B
A

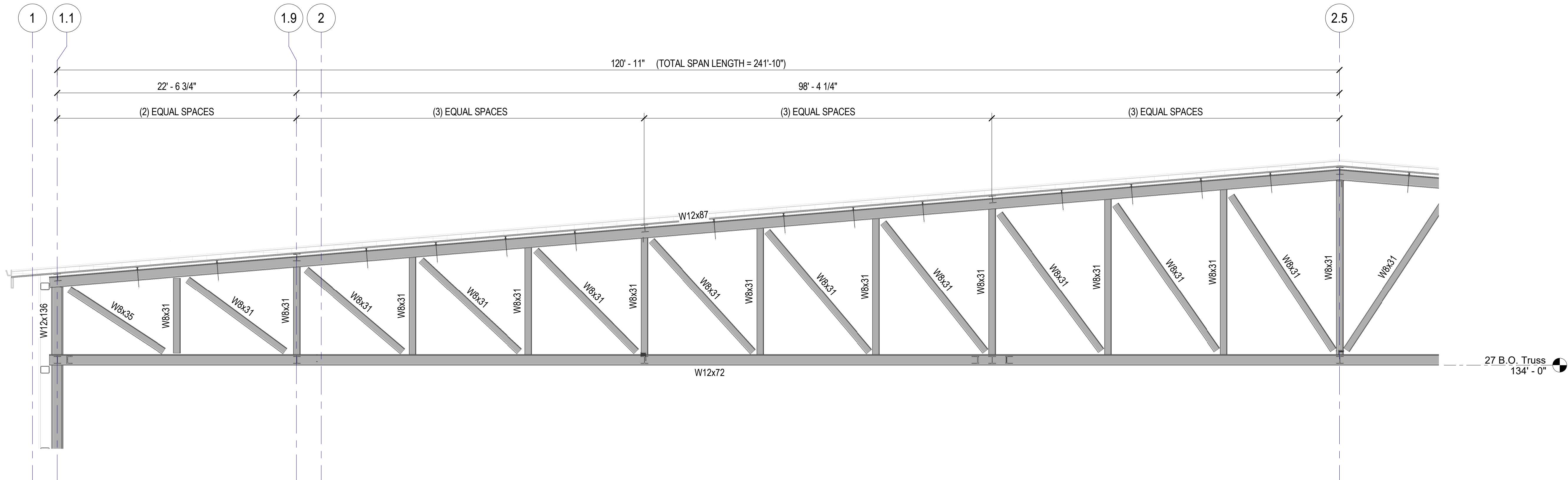

H2 GIRDER TRUSS TR-2 - GRIDS B C D (WEST)
3/16" = 1'-0" REF: SF131

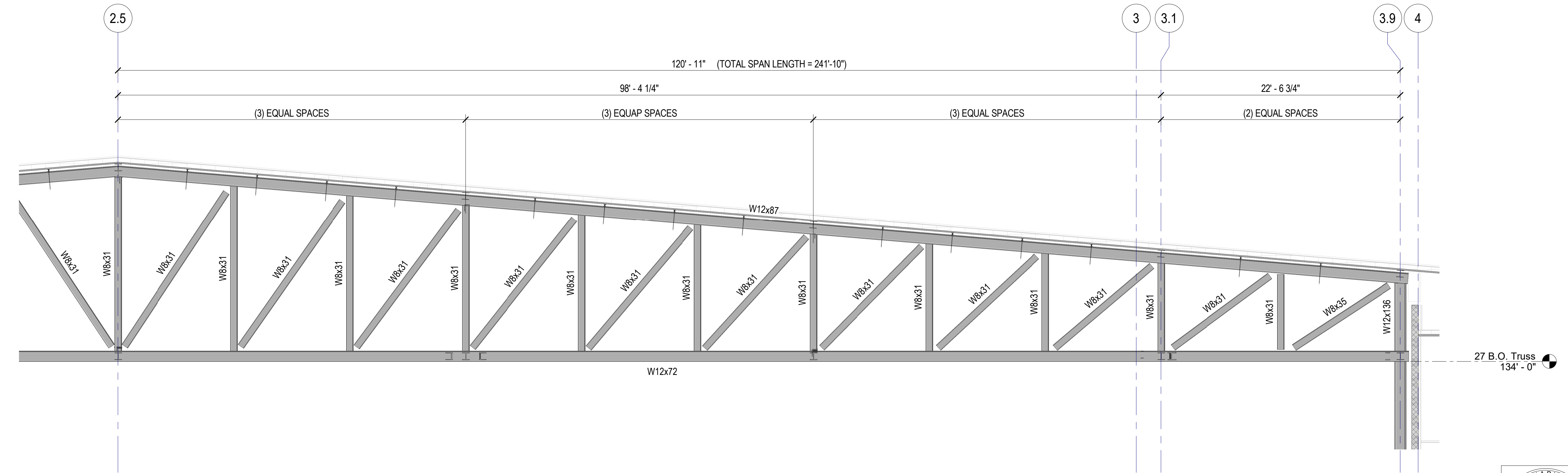

A2 GIRDER TRUSS TR-2 - GRIDS B C D (EAST)
3/16" = 1'-0" REF: SF131

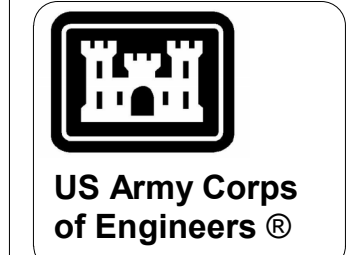
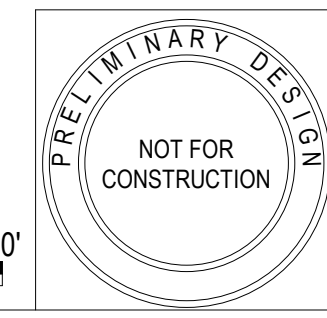

MARK	DESCRIPTION	DATE

DESIGNED BY: A. VALENCIA	ISSUE DATE: NOVEMBER 13, 2025
DRAWN BY: R. CARLSON	SOLICITATION NO.: W812PL25RA0012
CHECKED BY: D. CLAYSON	CONTRACT NO.: W812PL25C0037
SUBMITTED BY: P. PASZCZUK	ANSI D

US ARMY CORPS OF ENGINEERS
LOS ANGELES DISTRICT
KORTE CONSTRUCTION
5700 OAKLAND AVE. SUITE 275
ST. LOUIS, MO 63110

CREECH AIR FORCE BASE, CLARK COUNTY, NV
DISASTER RESILIENCY PROGRAM (DRP) - PHASE 2
494137
GIRDER TRUSS ELEVATIONS

SHEET ID
S-212

DP-1 95% SUBMISSION

1 2 3 4 5 6 7 8 9 10 11 12 13 14 15 16 17 18 19 20

P
N
M
L
K
J
H
G
F
E
D
C
B
A

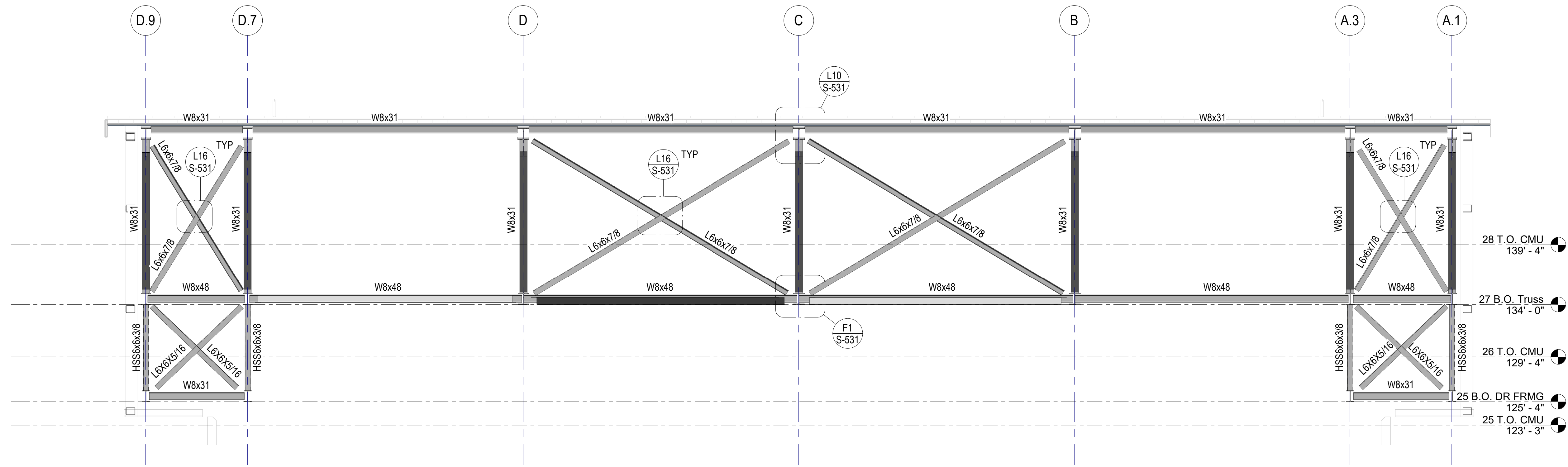

H3 TYPICAL GIRDER TRUSS VERTICAL BRACING ELEVATION
 3/16" = 1'-0" REF: SF131

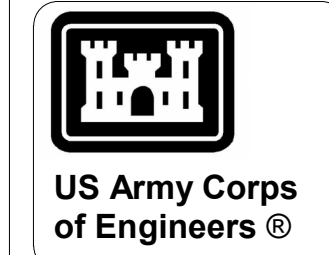
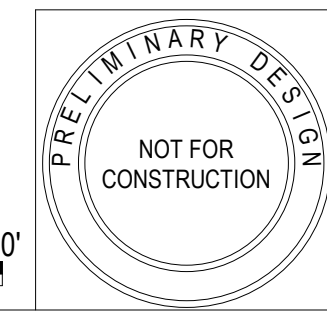
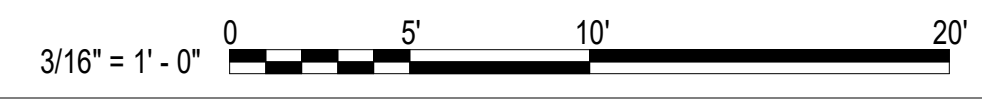

MARK	DESCRIPTION	DATE

DESIGNED BY: A. VALENCIA	ISSUE DATE: NOVEMBER 13, 2025
DRAWN BY: R. CARLSON	SOLICITATION NO.: W812PL25PRA0012
CHECKED BY: D. CLAYSON	CONTRACT NO.: W812PL25C0037
SUBMITTED BY: P. PASZCZUK	
SIZE: ANSI D	

US ARMY CORPS OF ENGINEERS
 LOS ANGELES DISTRICT
 KORTE CONSTRUCTION
 5700 OAKLAND AVE. SUITE 275
 ST. LOUIS, MO 63110

CREECH AIR FORCE BASE, CLARK COUNTY, NV
 DISASTER RESILIENCY PROGRAM (DRP) - PHASE 2
 494137
 TYPICAL GIRDER TRUSS VERTICAL BRACING
 ELEVATION

SHEET ID
S-213

DP-1 95% SUBMISSION

P
N
M
L
K
J
H
G
F
E
D
C
B
A

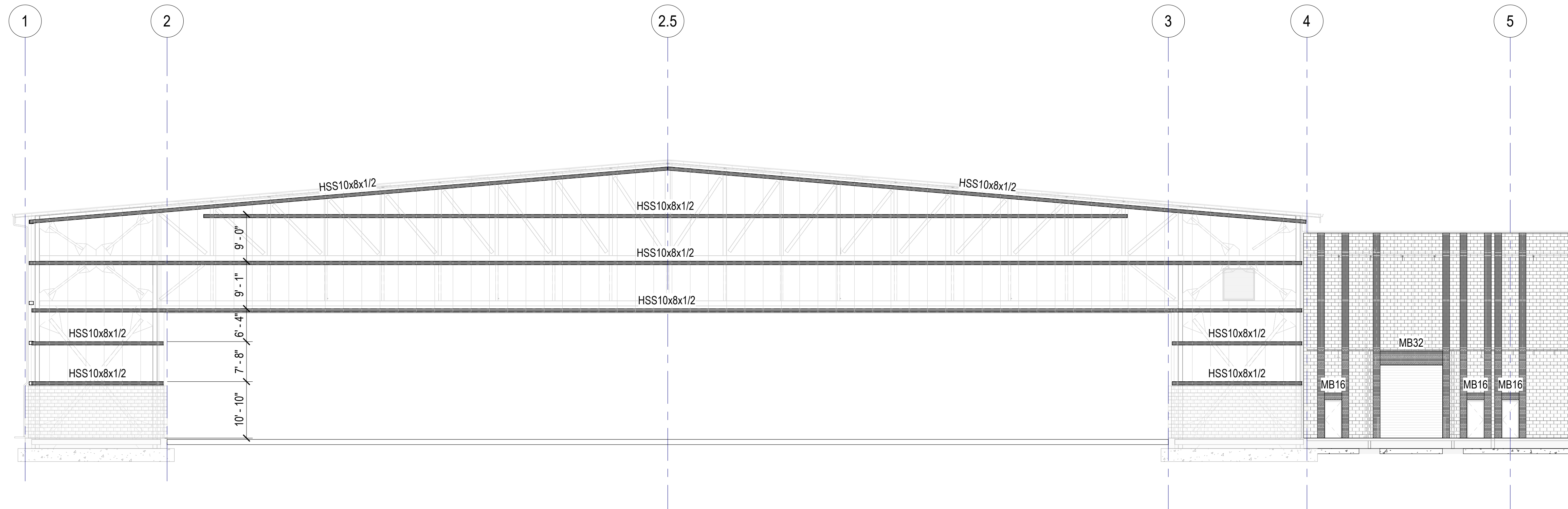

H2 WIND GIRT ELEVATION - SOUTH FACE, (WEST)
1 : 150 REF: SB101

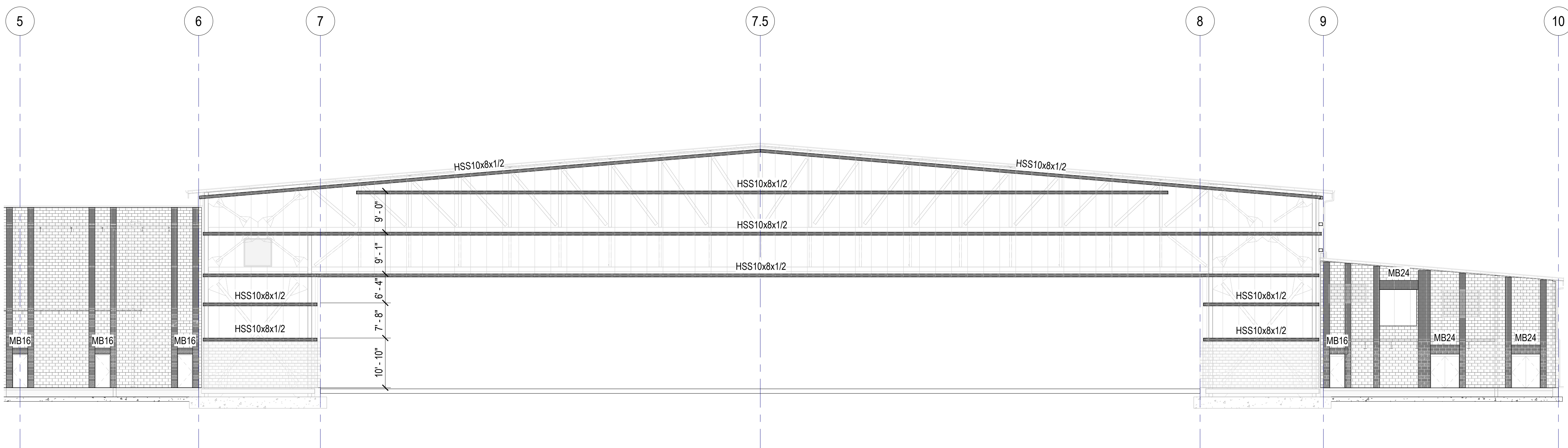

A2 WIND GIRT ELEVATION - SOUTH FACE, (EAST)
1 : 150 REF: SB103

1" = 150' - 0"

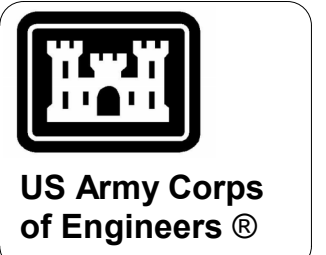
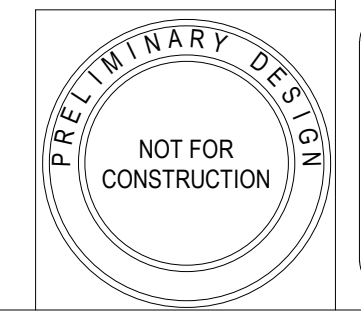

US Army Corps of Engineers®

MARK	DESCRIPTION	DATE

DESIGNED BY: A. VALENCIA	ISSUE DATE: NOVEMBER 13, 2025
DRAWN BY: R. CARLSON	SOLICITATION NO.: WB12PL25RA0012
CHECKED BY: D. CLAYSON	CONTRACT NO.: WB12PL25C0037
SUBMITTED BY: P. PASZCZUK	SIZE: ANSI D

US ARMY CORPS OF ENGINEERS
LOS ANGELES DISTRICT

KORTE CONSTRUCTION
5700 OAKLAND AVE. SUITE 275
ST. LOUIS, MO 63110

CREECH AIR FORCE BASE, CLARK COUNTY, NV
DISASTER RESILIENCY PROGRAM (DRP) - PHASE 2
494137
WIND GIRT ELEVATIONS

SHEET ID
S-220

DP-1 95% SUBMISSION

P
N
M
L
K
J
H
G
F
E
D
C
B
A

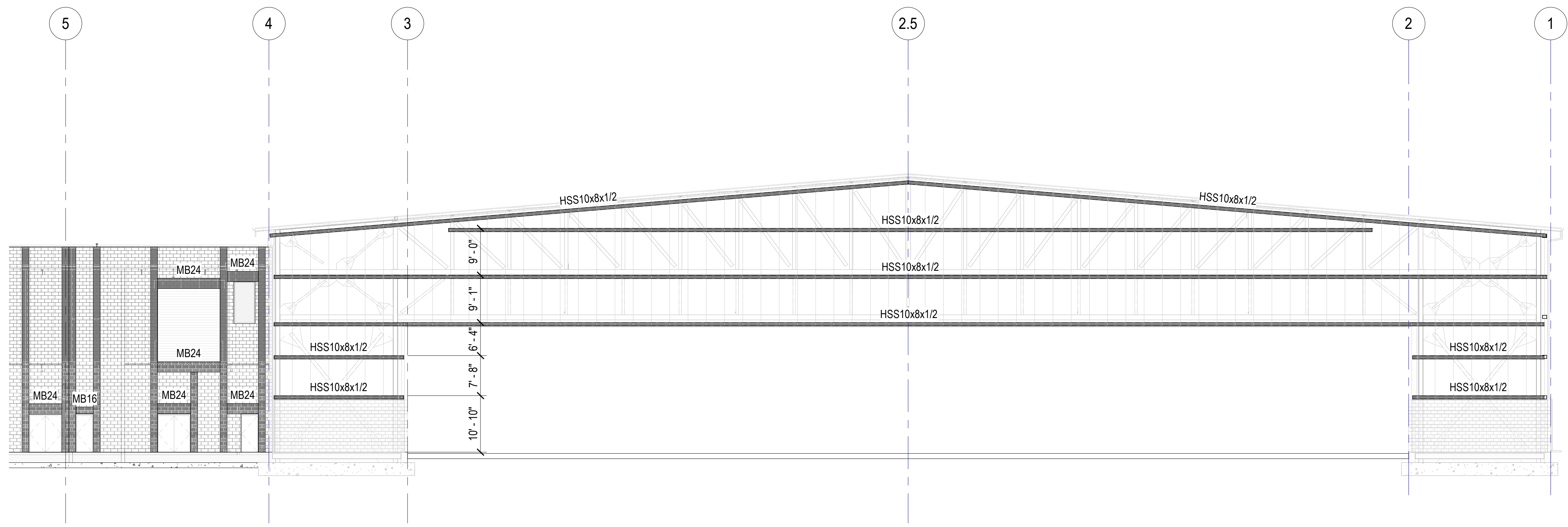

H2 WIND GIRT ELEVATION - NORTH FACE, (WEST)
1 : 150 REF: SB101

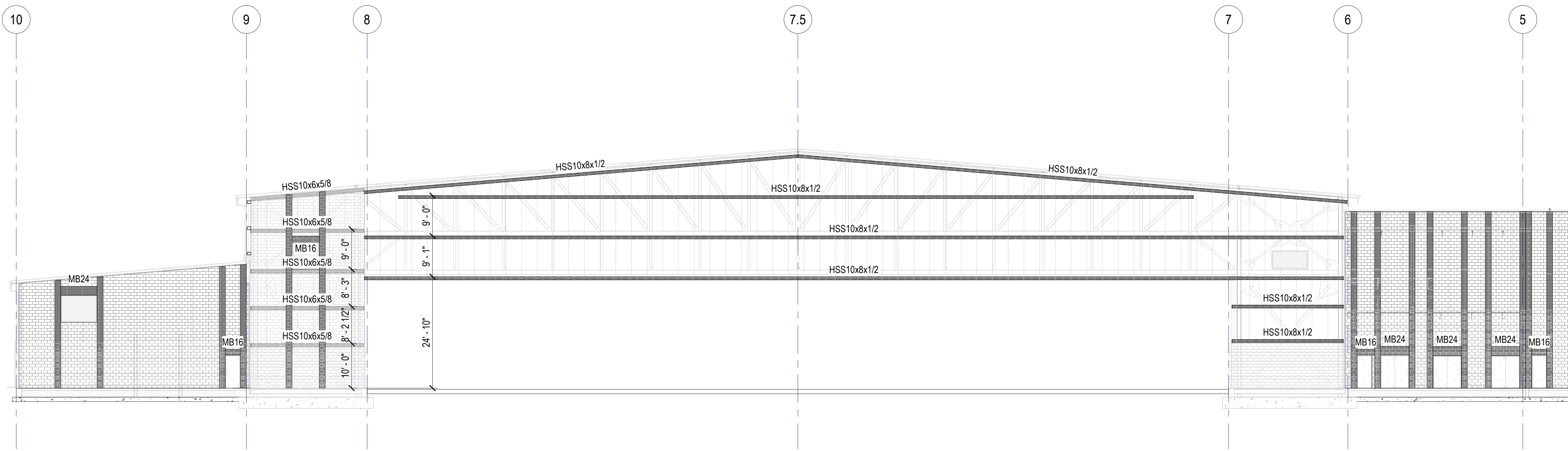

A2 WIND GIRT ELEVATION - NORTH FACE, (EAST)
1 : 150 REF: SB103

1" = 150' - 0"

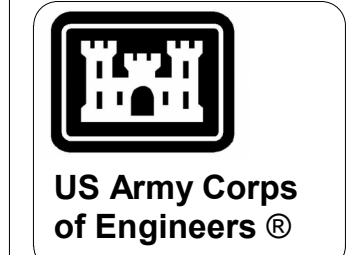
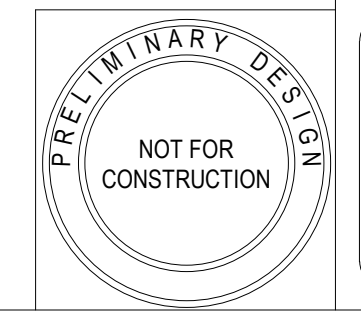

MARK	DESCRIPTION	DATE

DESIGNED BY: A. VALENCIA	ISSUE DATE: NOVEMBER 13, 2025
DRAWN BY: R. CARLSON	SOLICITATION NO.: WB12PL25RA0012
CHECKED BY: D. CLAYSON	CONTRACT NO.: WB12PL25C0037
SUBMITTED BY: P. PASZCZUK	SIZE: ANSI D

US ARMY CORPS OF ENGINEERS
LOS ANGELES DISTRICT
KORTE CONSTRUCTION
5700 OAKLAND AVE. SUITE 275
ST. LOUIS, MO 63110

CREECH AIR FORCE BASE, CLARK COUNTY, NV
DISASTER RESILIENCY PROGRAM (DRP) - PHASE 2
494137
WIND GIRT ELEVATIONS

SHEET ID
S-221

DP-1 95% SUBMISSION

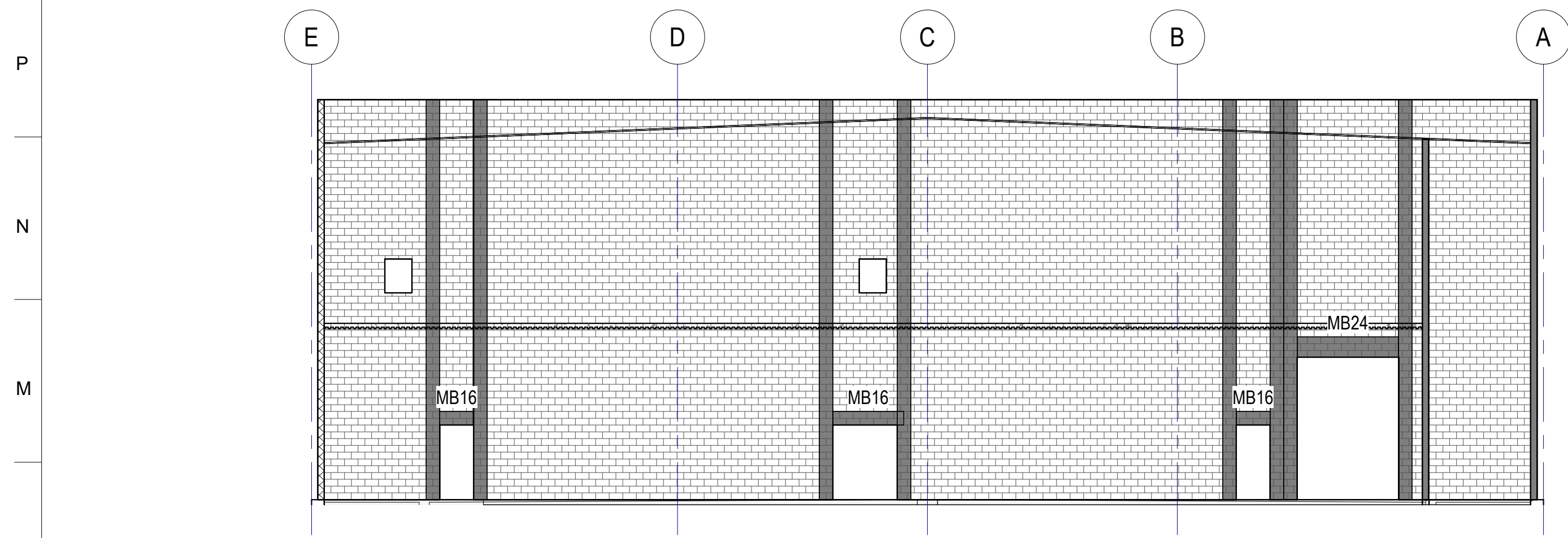

L2 CMU WALL ELEVATION - GRID 6
3/32" = 1'-0" REF: SB103

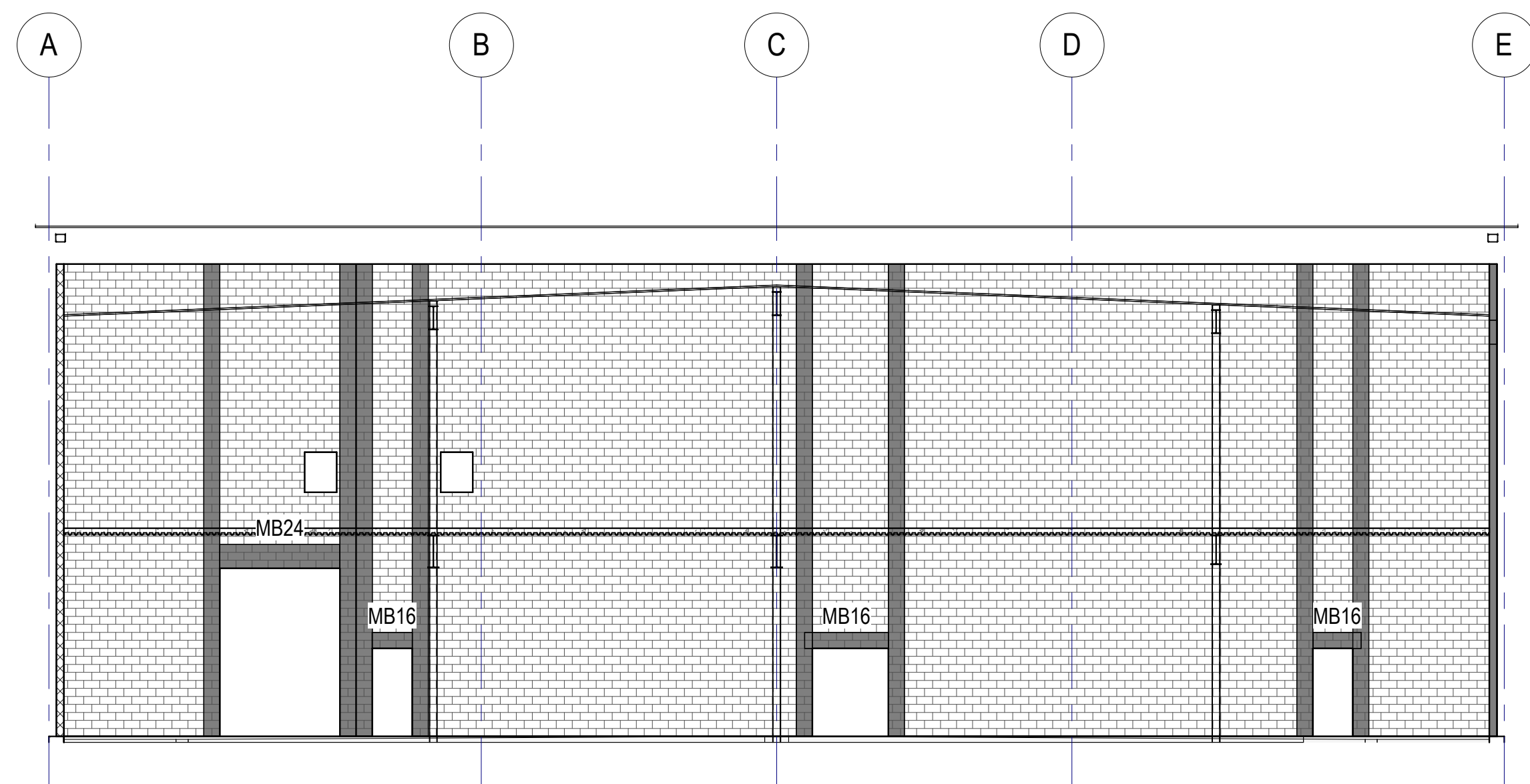

F2 CMU WALL ELEVATION - GRID 4
3/32" = 1'-0" REF: S-512

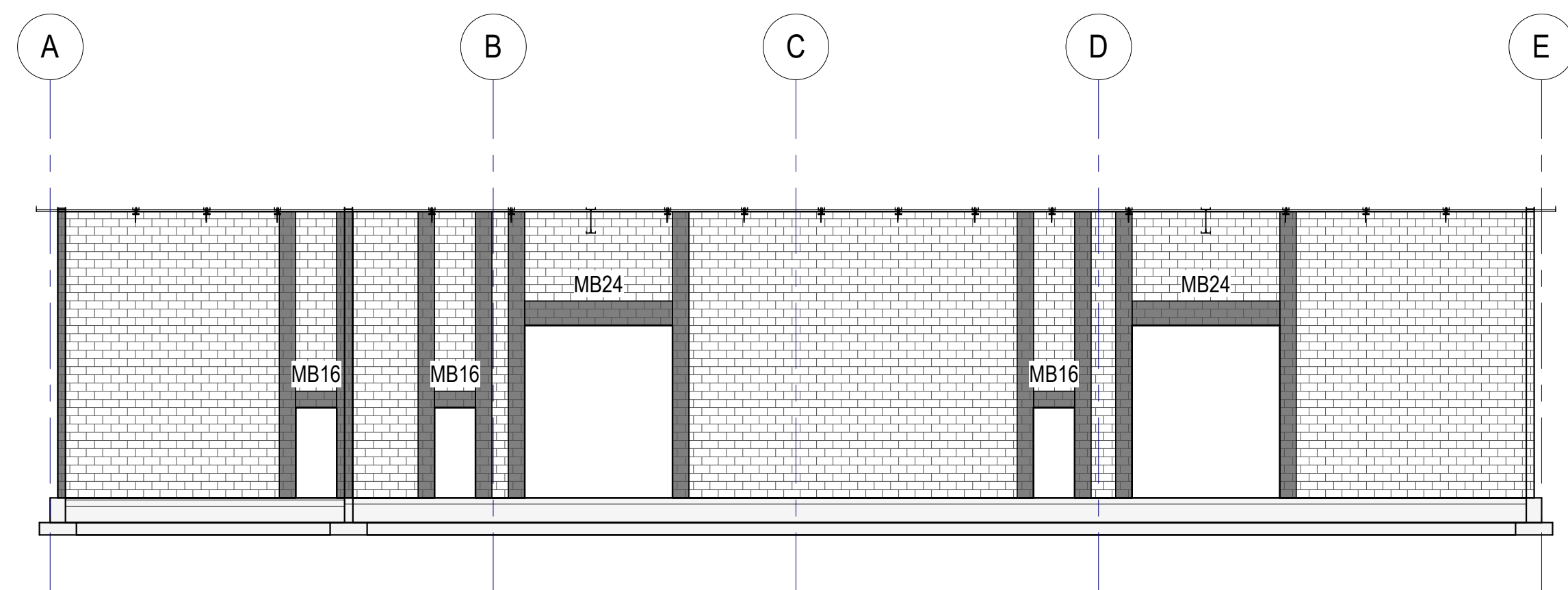

B2 CMU WALL ELEVATION - EAST, GRID 10
3/32" = 1'-0" REF: SB105

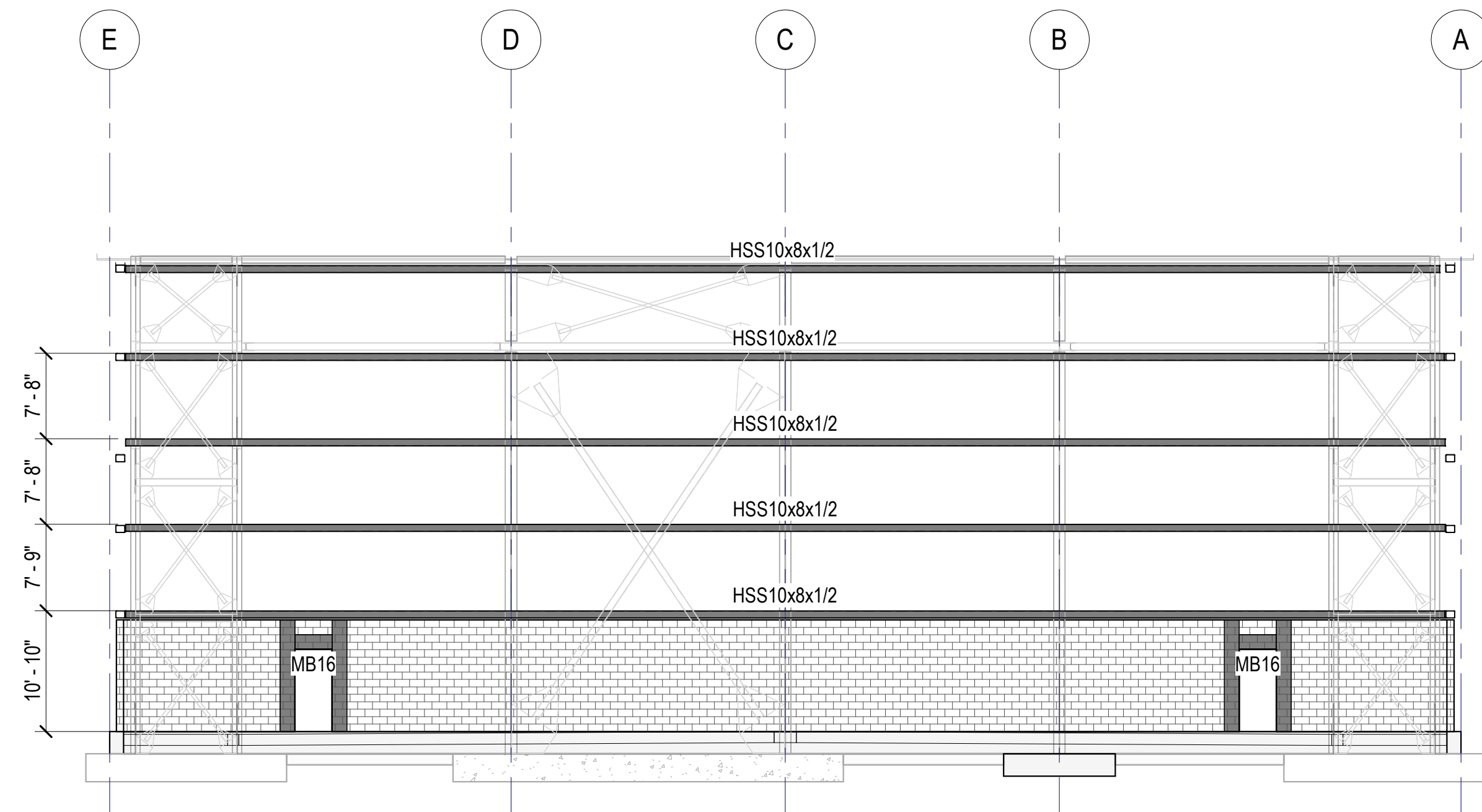

H10 WIND GIRTS ELEVATION - WEST
3/32" = 1'-0" REF: SB101

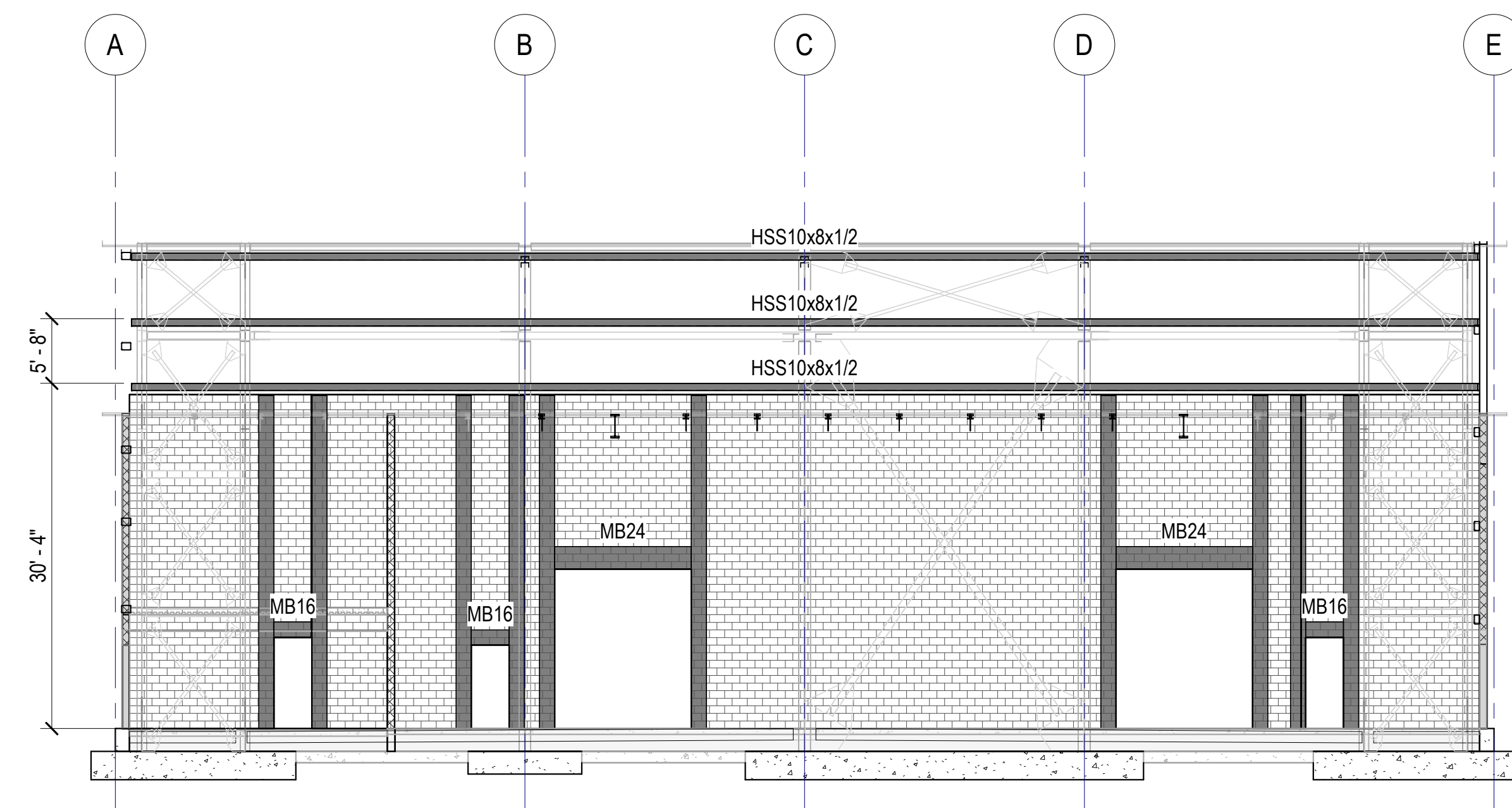

A10 WIND GIRTS ELEVATION - EAST, GRID 9
3/32" = 1'-0" REF: SB105

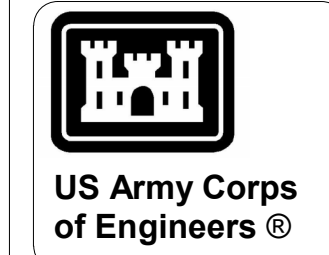
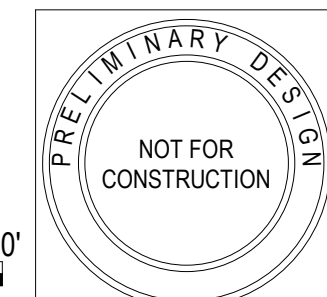

MARK	DESCRIPTION	DATE

DESIGNED BY: A. VALENCIA	ISSUE DATE: NOVEMBER 13, 2025
DRAWN BY: R. CARLSON	SOLICITATION NO.: WB12PL25RA0012
CHECKED BY: D. CLAYSON	CONTRACT NO.: WB12PL25C0037
SUBMITTED BY: P. PASZCZUK	
SIZE: ANSI D	

US ARMY CORPS OF ENGINEERS
LOS ANGELES DISTRICT

KORTE CONSTRUCTION
5700 OAKLAND AVE, SUITE 275
ST. LOUIS, MO 63110

CREECH AIR FORCE BASE, CLARK COUNTY, NV
DISASTER RESILIENCY PROGRAM (DRP) - PHASE 2
494137

WIND GIRTS / CMU WALL ELEVATIONS

SHEET ID
S-222

P
N
M
L
K
J
H
G
F
E
D
C
B
A

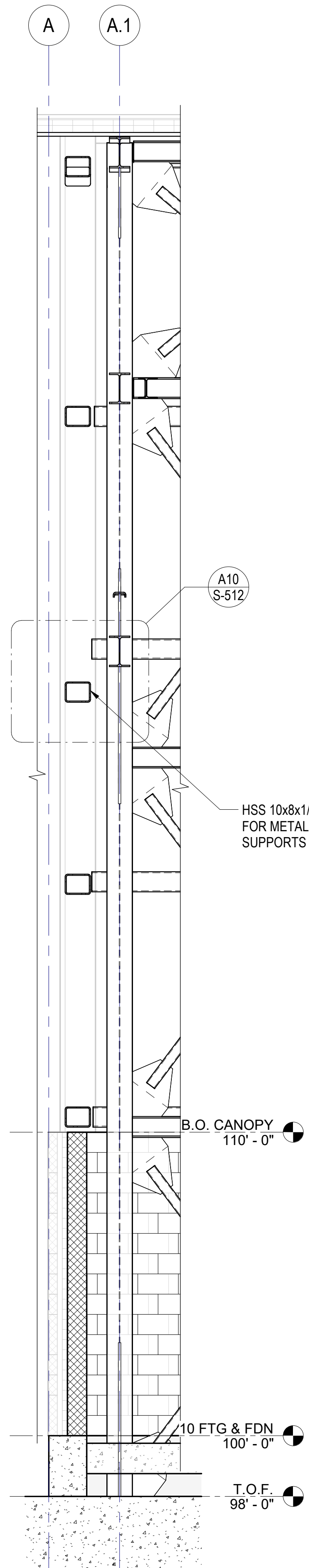

A1 EXTERIOR WALL SECTION
3/8" = 1'-0" REF: S-202

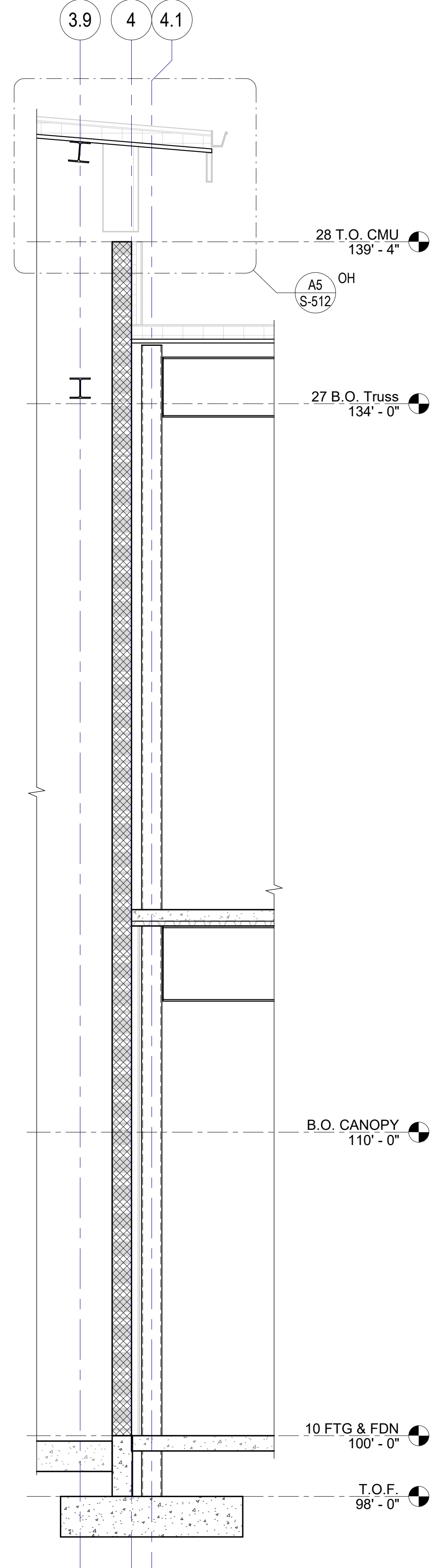

A6 WALL SECTION
3/8" = 1'-0" REF: S-203

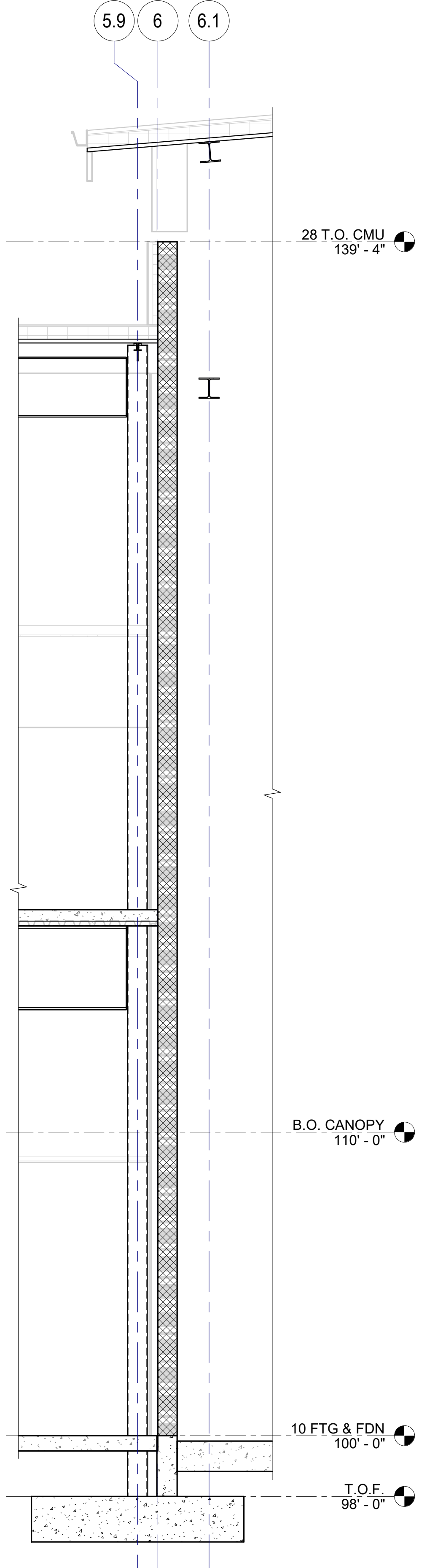

A10 WALL SECTION
3/8" = 1'-0" REF: SB103

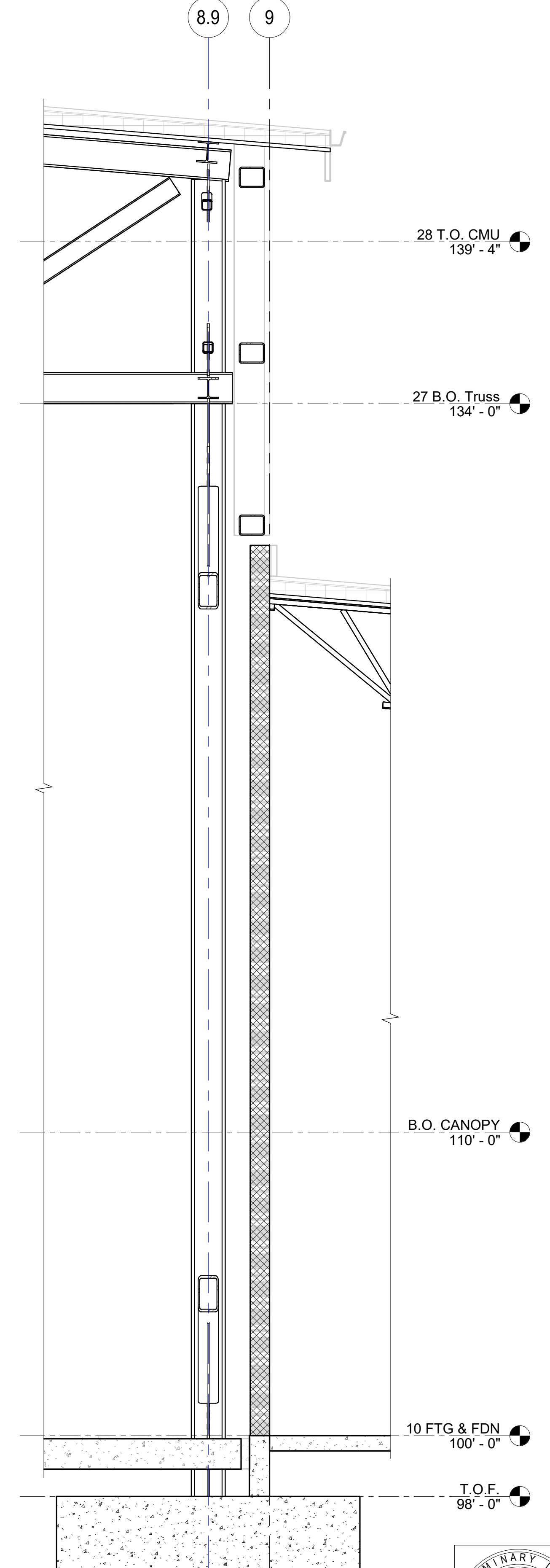

A16 WALL SECTION
3/8" = 1'-0" REF: SB105

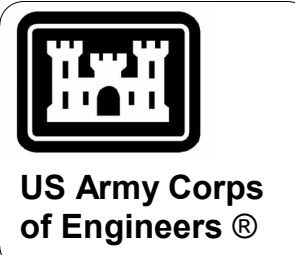
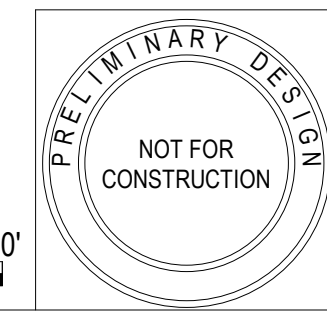
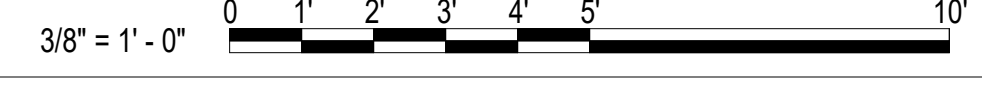

US Army Corps of Engineers®

MARK	DESCRIPTION	DATE

DESIGNED BY: A. VALENCIA	ISSUE DATE: NOVEMBER 13, 2025
DRAWN BY: R. CARLSON	SOLICITATION NO.: W812PL25RA0012
CHECKED BY: D. CLAYSON	CONTRACT NO.: W812PL25C0037
SUBMITTED BY: P. PASZCZUK	SIZE: ANSI D

US ARMY CORPS OF ENGINEERS
LOS ANGELES DISTRICT

KORTE CONSTRUCTION
5700 OAKLAND AVE. SUITE 275
ST. LOUIS, MO 63110

CREECH AIR FORCE BASE, CLARK COUNTY, NV
DISASTER RESILIENCY PROGRAM (DRP) - PHASE 2
494137

WALL SECTIONS

SHEET ID
S-301

DP-1 95% SUBMISSION

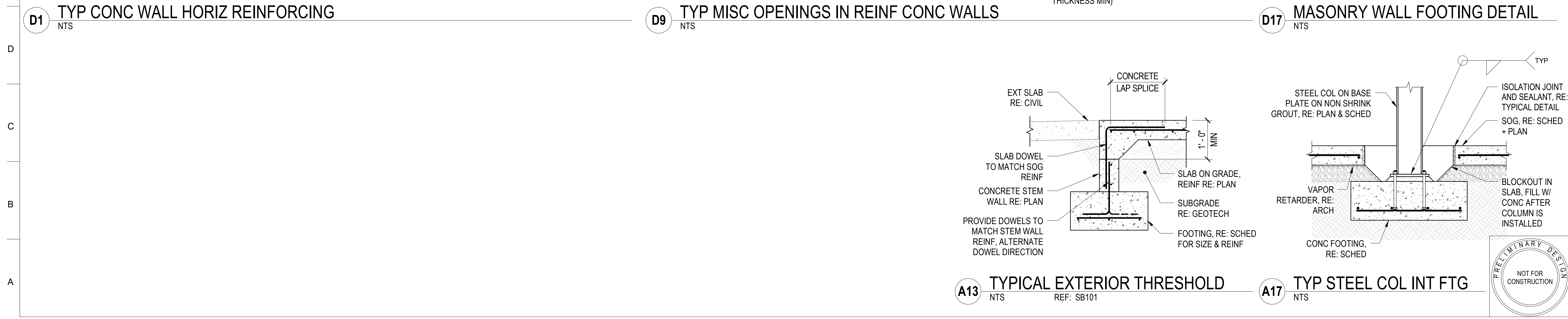
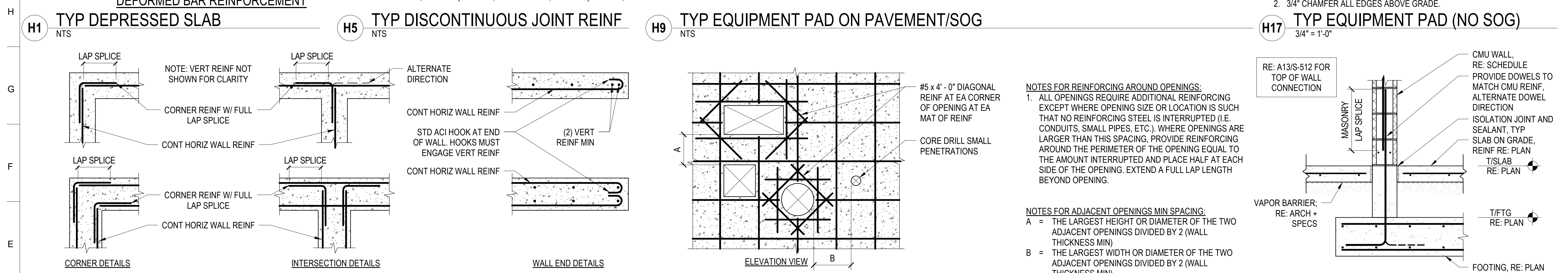
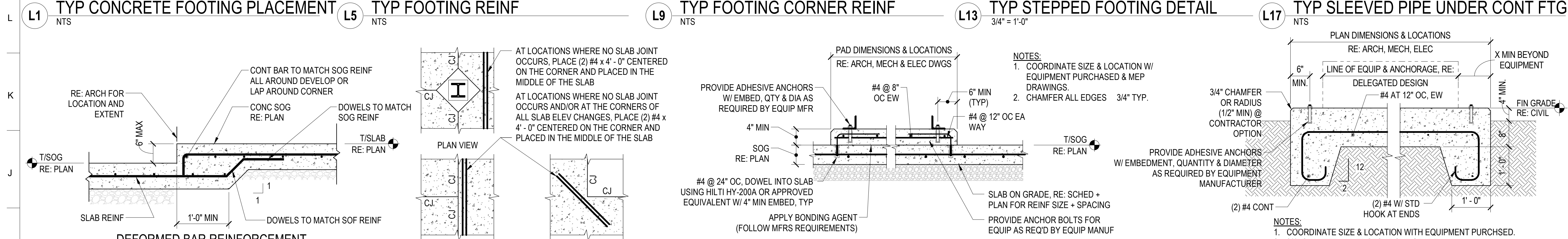
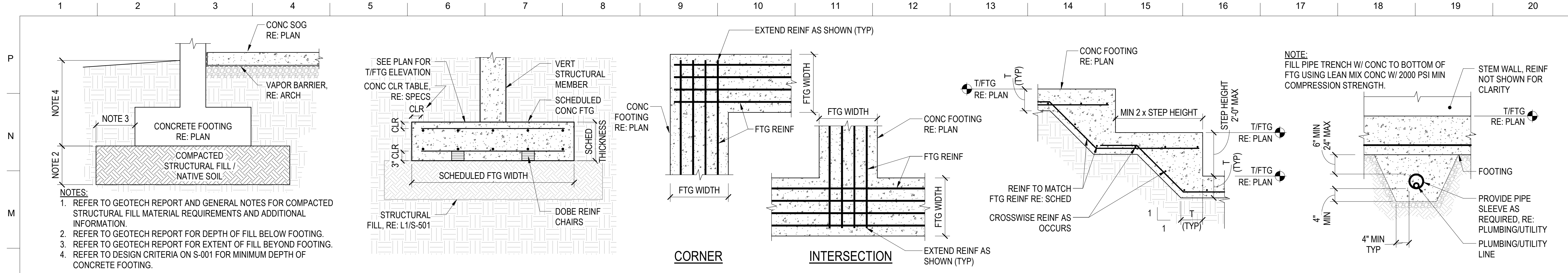

US Army Corps of Engineers

DESIGNED BY: A. VALENCIA
 DRAWN BY: R. CARLSON
 CHECKED BY: D. CLAYSON
 SUBMITTED BY: P. PASZCZUK

ISSUE DATE: NOVEMBER 13, 2025
 SOLICITATION NO.: W812PL25RA0012
 CONTRACT NO.: W812PL25C0037
 SIZE: ANS/D

US ARMY CORPS OF ENGINEERS
 LOS ANGELES DISTRICT

KORTE CONSTRUCTION
 5700 OAKLAND AVE, SUITE 275
 ST. LOUIS, MO 63110

CREECH AIR FORCE BASE, CLARK COUNTY, NV
 DISASTER RESILIENCY PROGRAM (DRP) - PHASE 2
 494137

FOUNDATION DETAILS

SHEET ID
S-501

DATE
 DESCRIPTION
 MARK

DP-1 95% SUBMISSION

TRENCH DRAIN AND COVER PLATE DETAIL IN PROGRESS

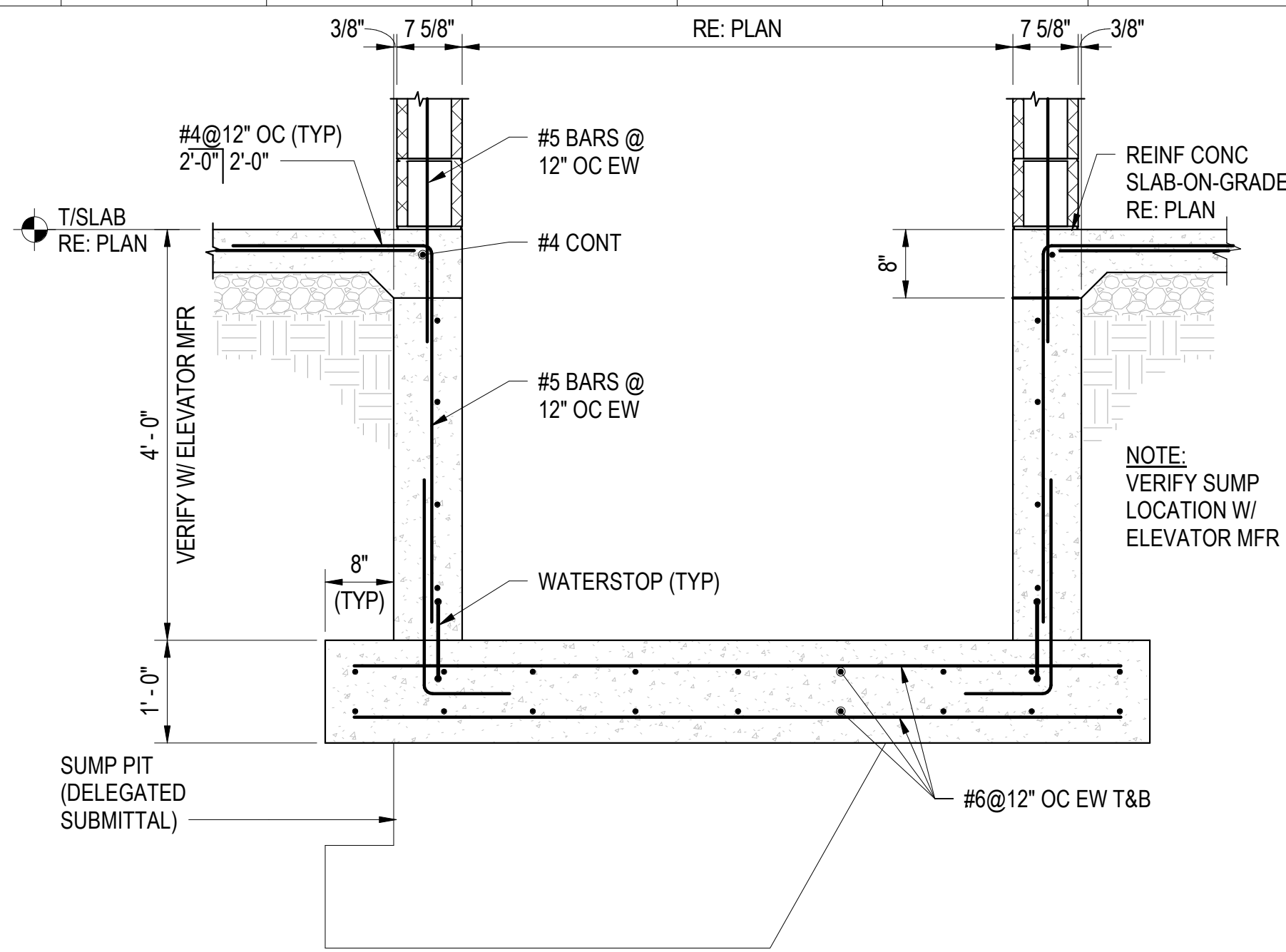

K8 ELEVATOR PIT
NTS REF: SB103

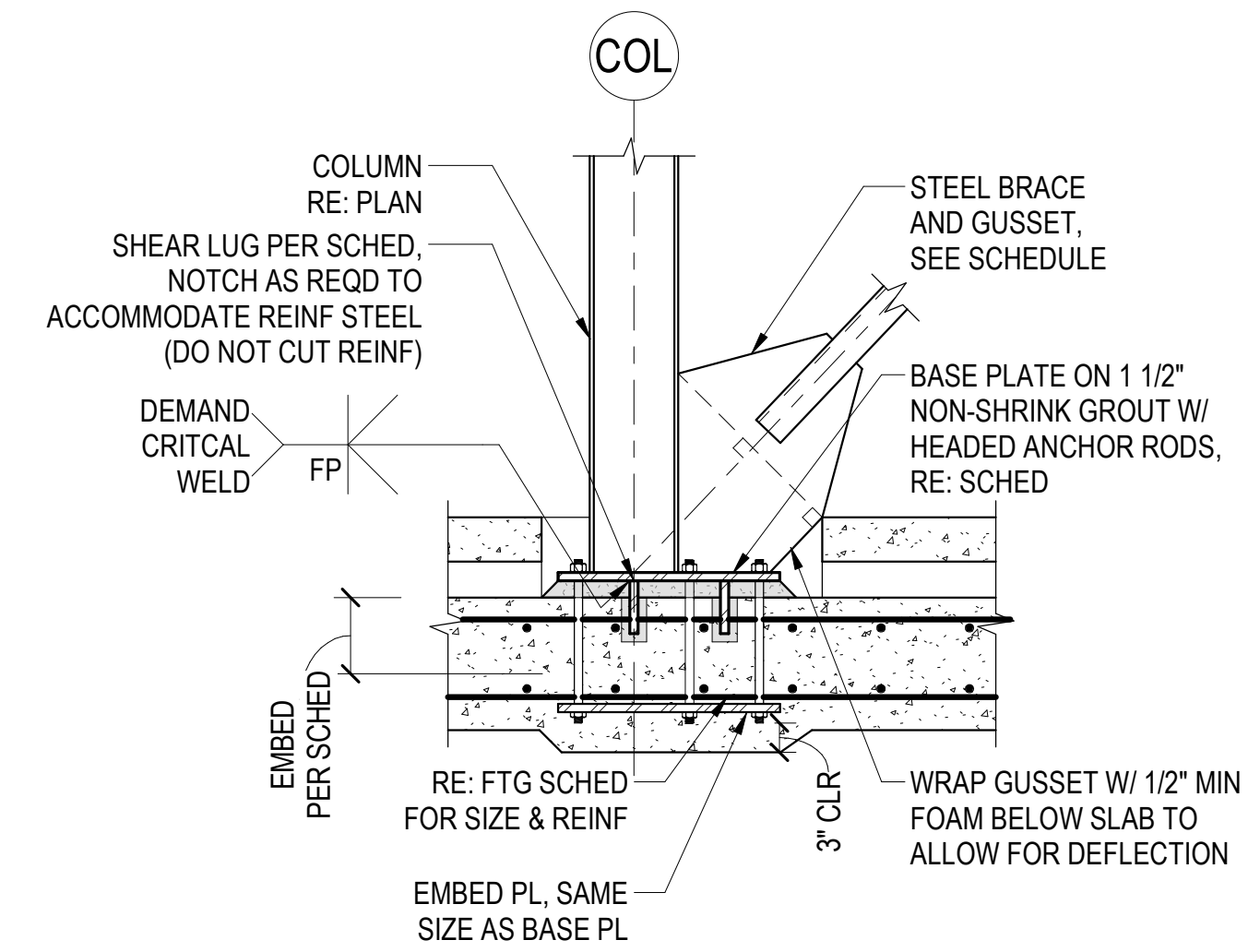

K15 BRACED FRAME @ FOOTING W/ EMBED PLATE
NTS

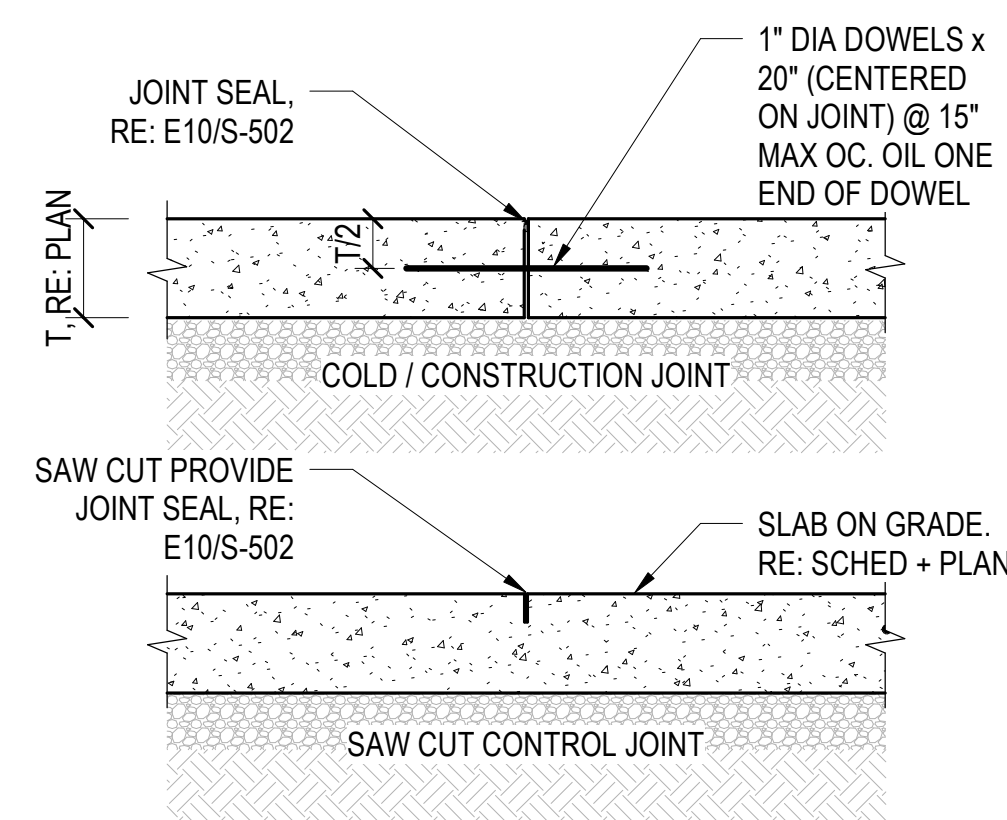

E6 TYP SOG JOINTS
NTS

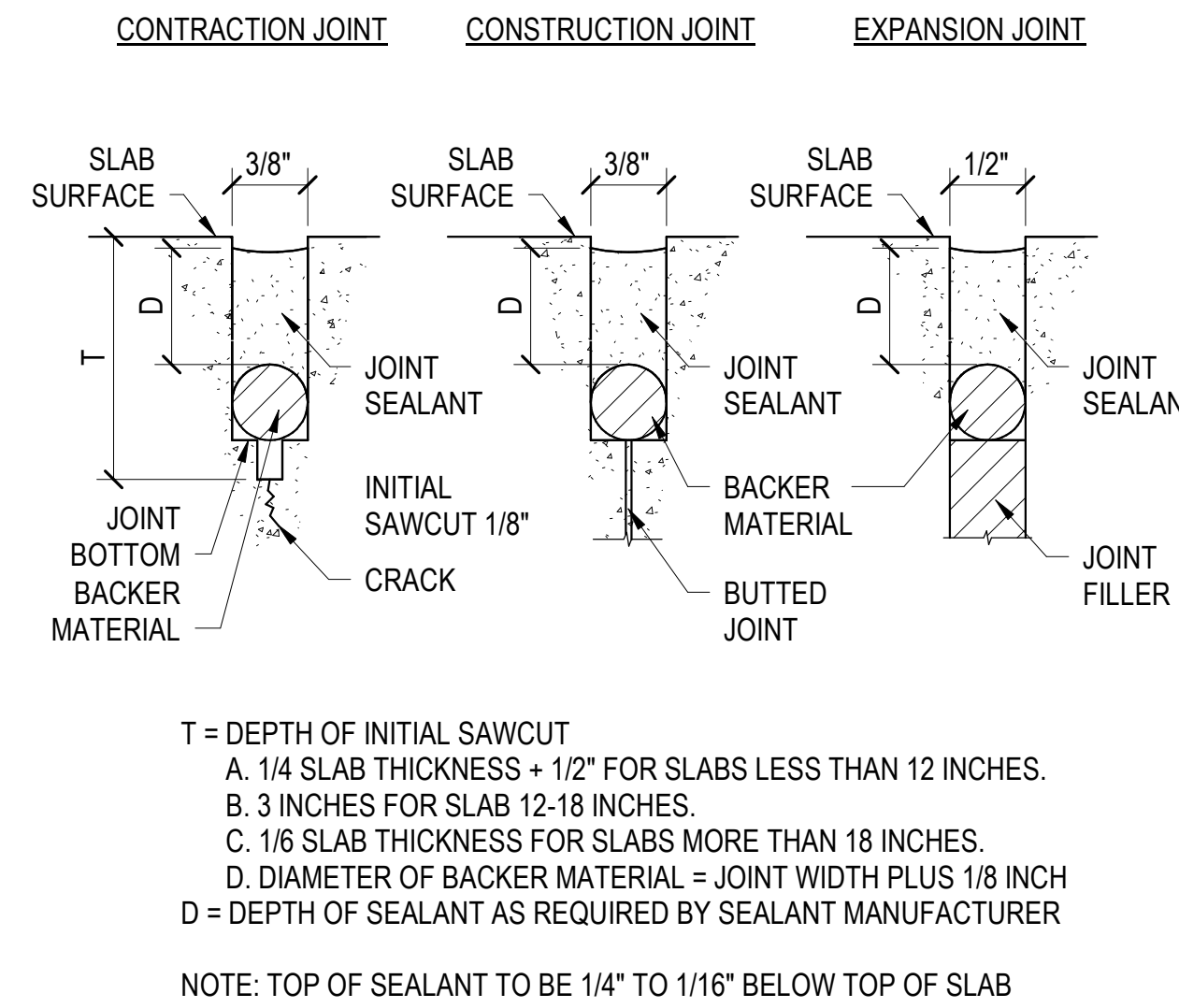

E10 TYP JOINT SEALANT @ CONC SOG
NTS

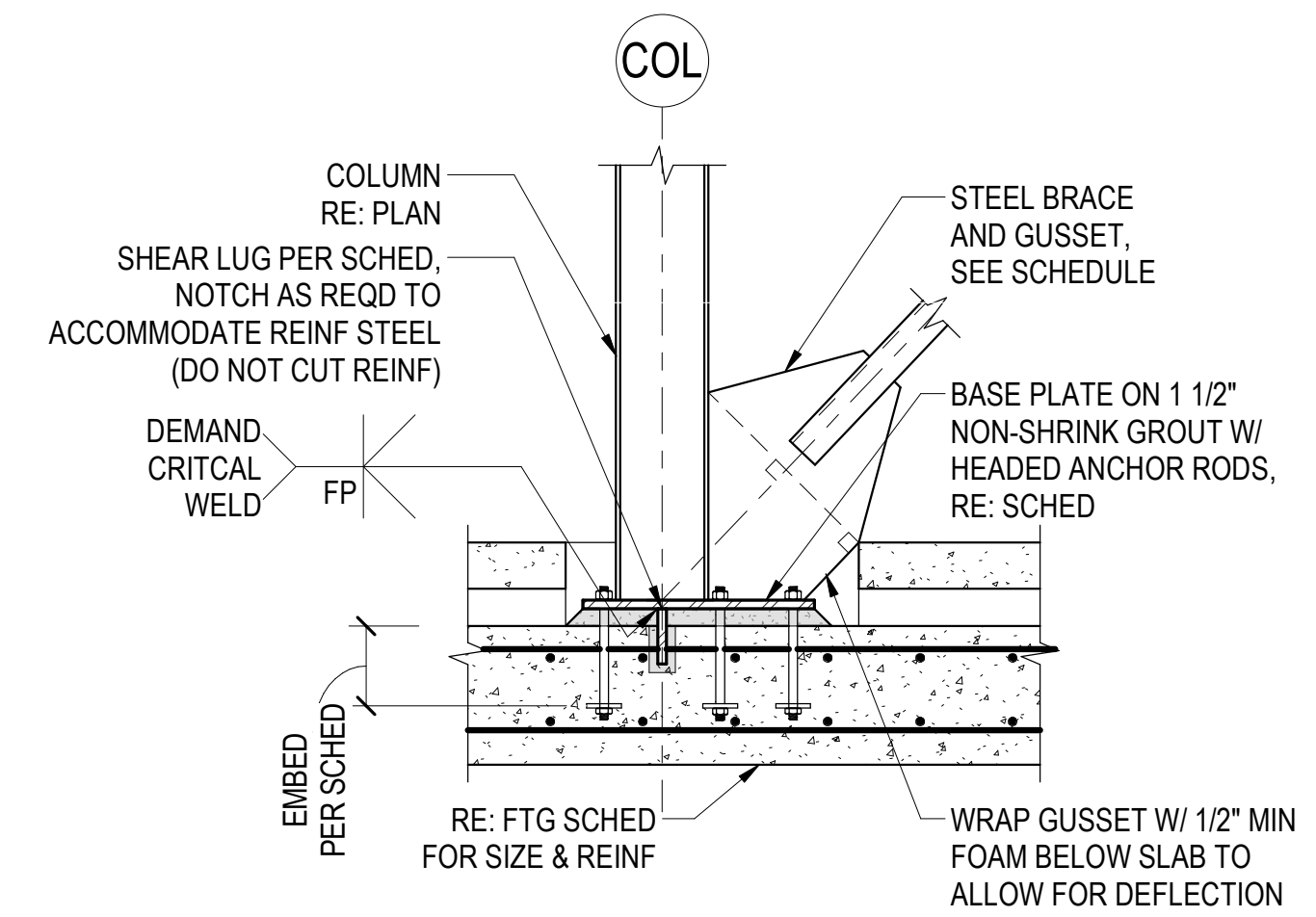

E15 TYP BRACED FRAME @ FOOTING DETAIL
NTS REF: S-201

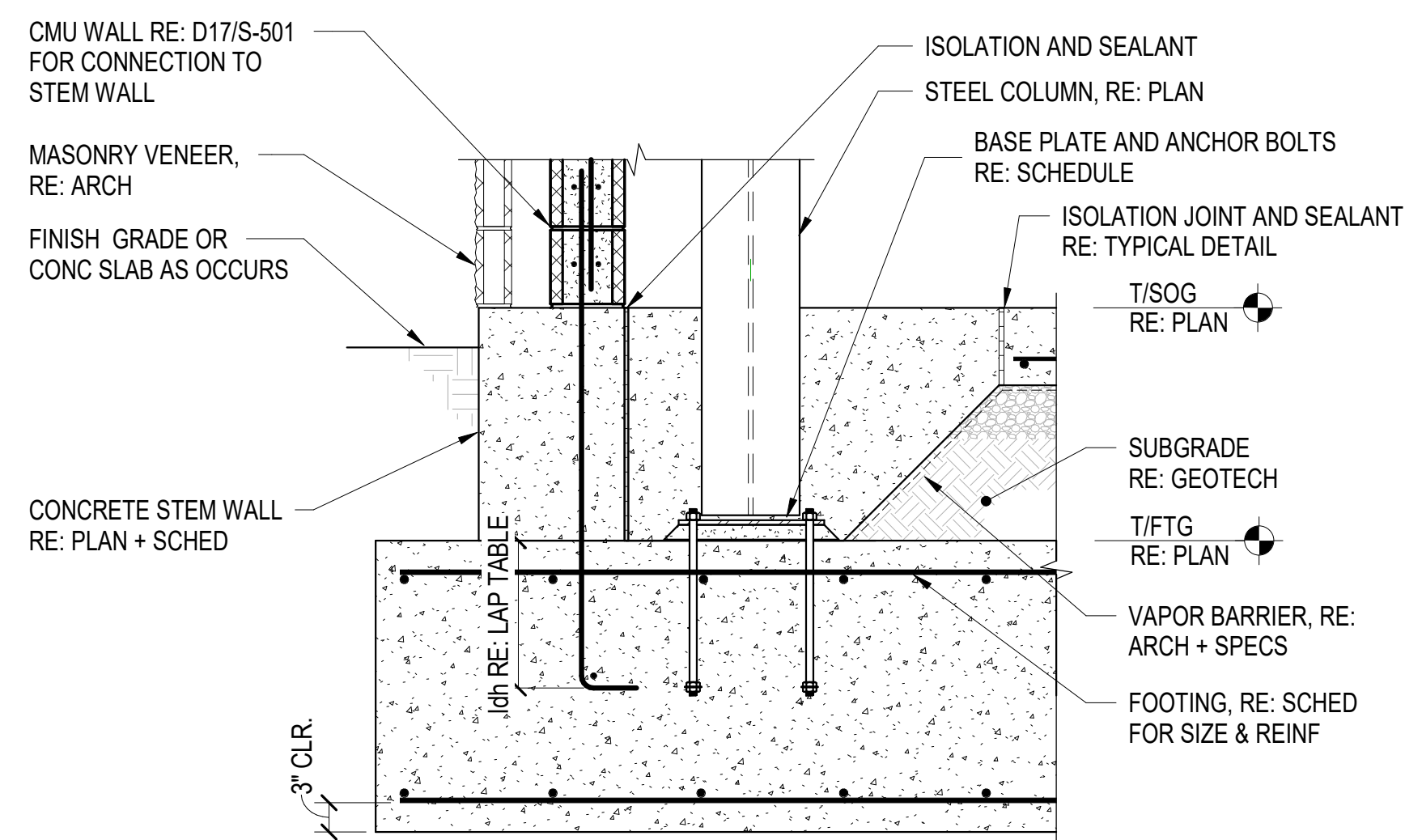

A5 TYP. EXTERIOR FOOTING DETAIL
NTS

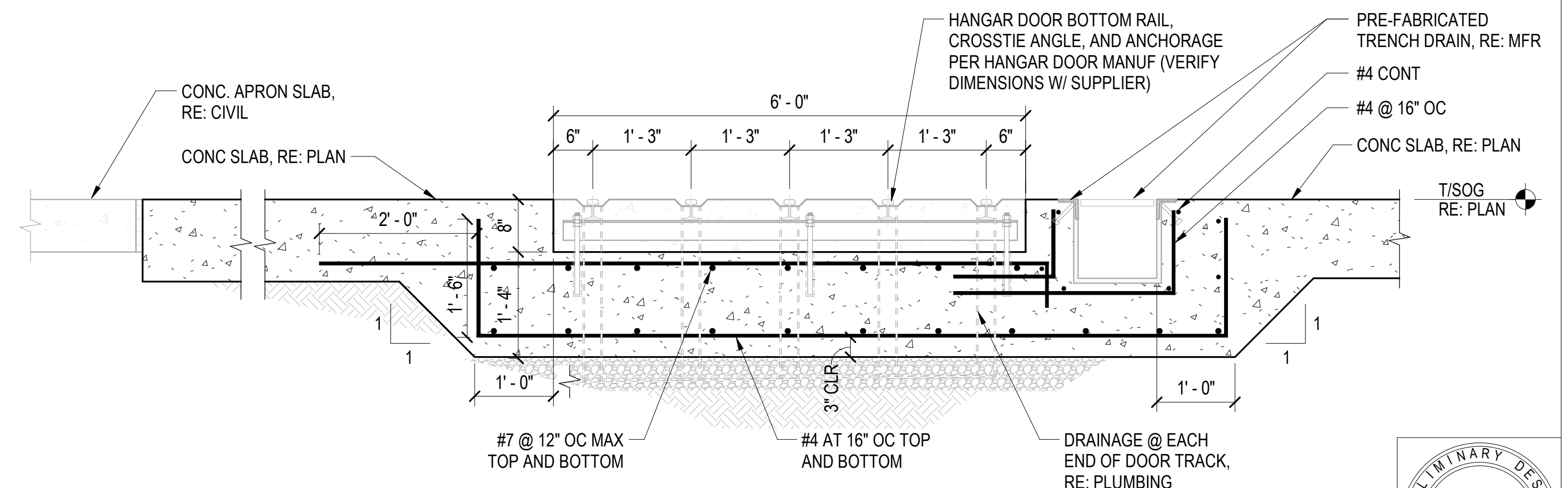

A12 HANGAR DOOR SUPPORT RAILS AND FOUNDATION
NTS REF: SB101



US Army Corps of Engineers

MARK	DESCRIPTION	DATE

DESIGNED BY: A. VALENCIA	ISSUE DATE: NOVEMBER 13, 2025
DRAWN BY: R. CARLSON	SOLICITATION NO. W812PL25RA0012
CHECKED BY: D. CLAYSON	CONTRACT NO. W812PL25C0037
SUBMITTED BY: P. PASZCZUK	ANSI D

US ARMY CORPS OF ENGINEERS
LOS ANGELES DISTRICT

KORTE CONSTRUCTION
5700 OAKLAND AVE. SUITE 275
ST. LOUIS, MO 63110

CREECH AIR FORCE BASE, CLARK COUNTY, NV
DISASTER RESILIENCY PROGRAM (DRP) - PHASE 2
494137

FOUNDATION DETAILS

SHEET ID
S-502

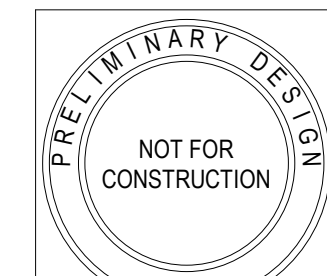

DP-1 95% SUBMISSION

P
N
M
L
K
J
H
G
F
E
D
C
B
A

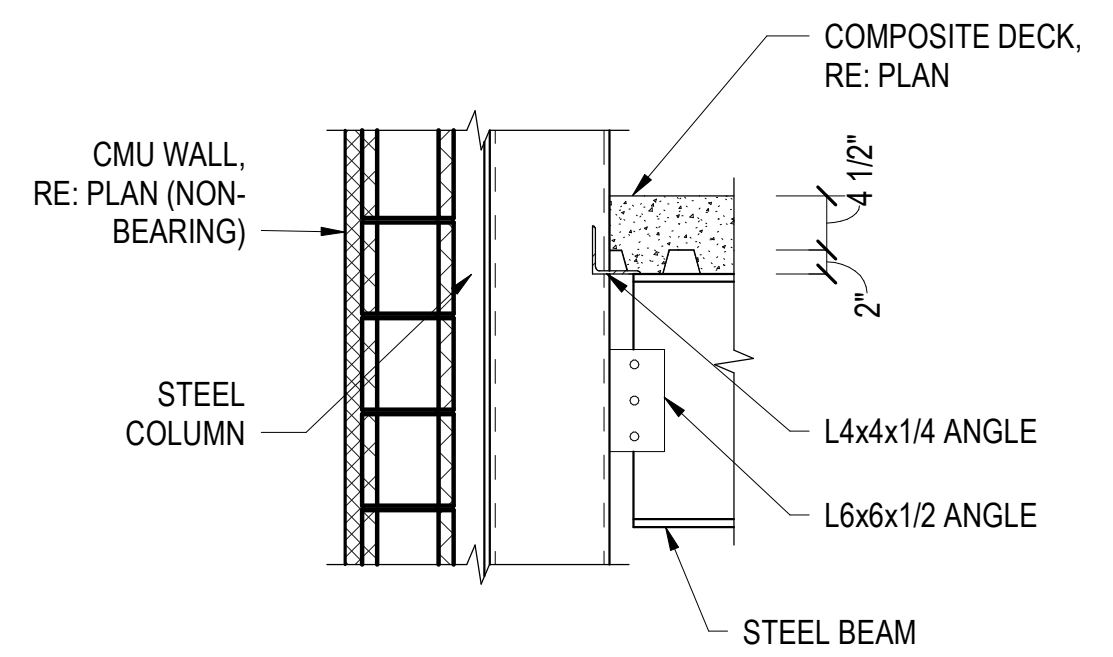

K1 TYP. COMPOSITE DESK EDGE AT CMU
NTS REF: SF121

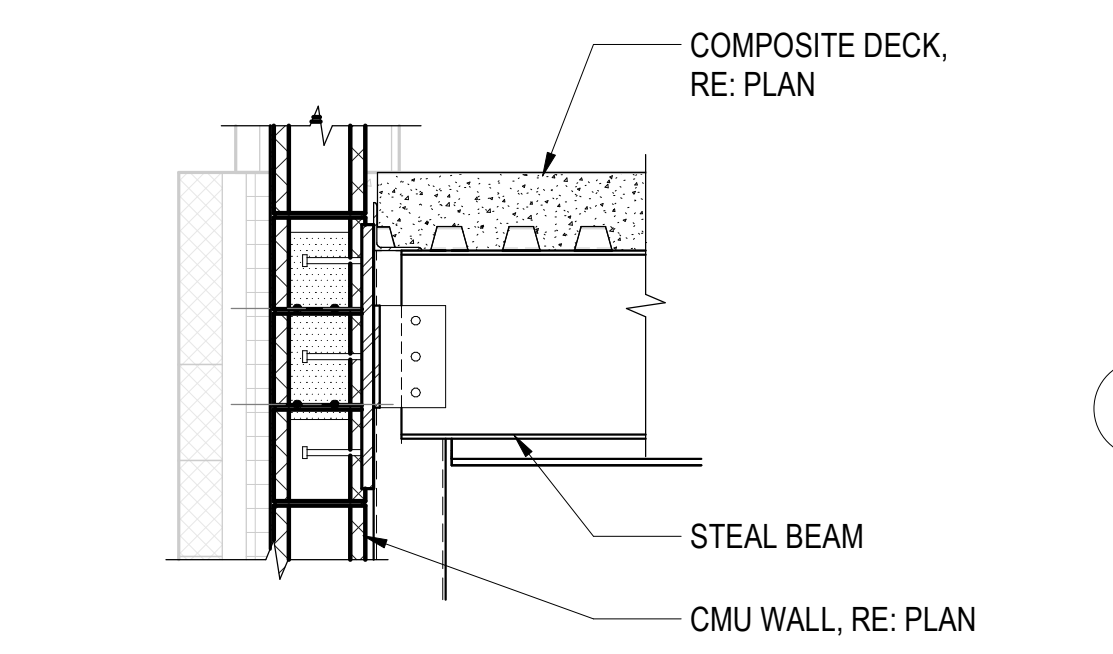

G1 TYP. COMPOSITE DESK EDGE AT CMU
NTS REF: SF121

**CONNECTION
DETAILS IN
PROGRESS**

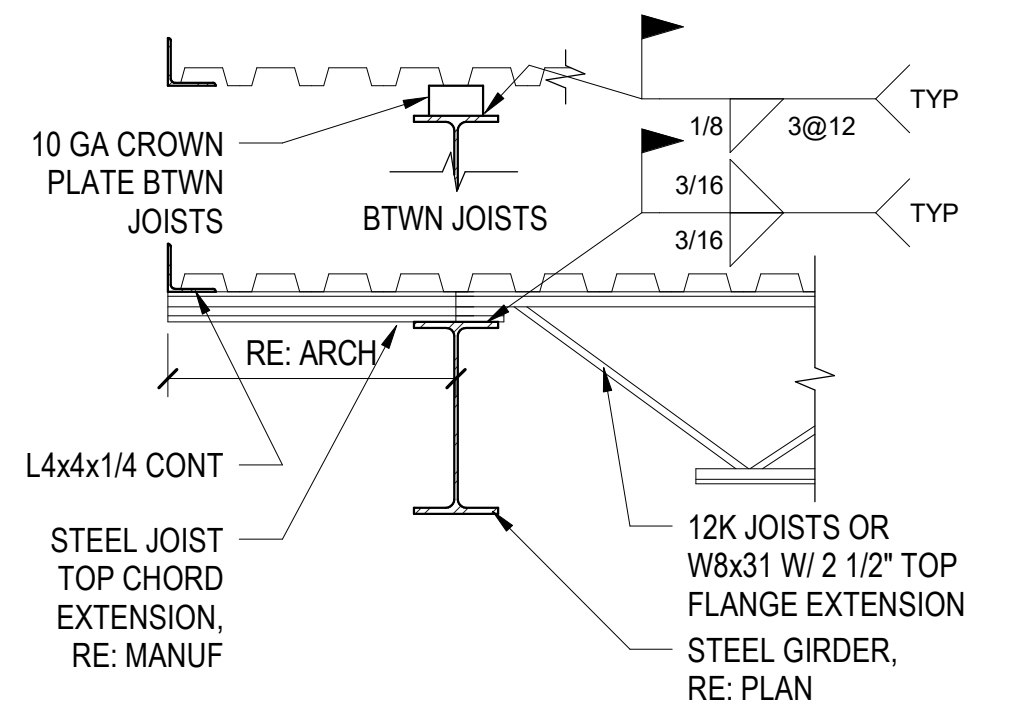

H5 TYP ROOF JOIST ON EDGE GIRDER
NTS

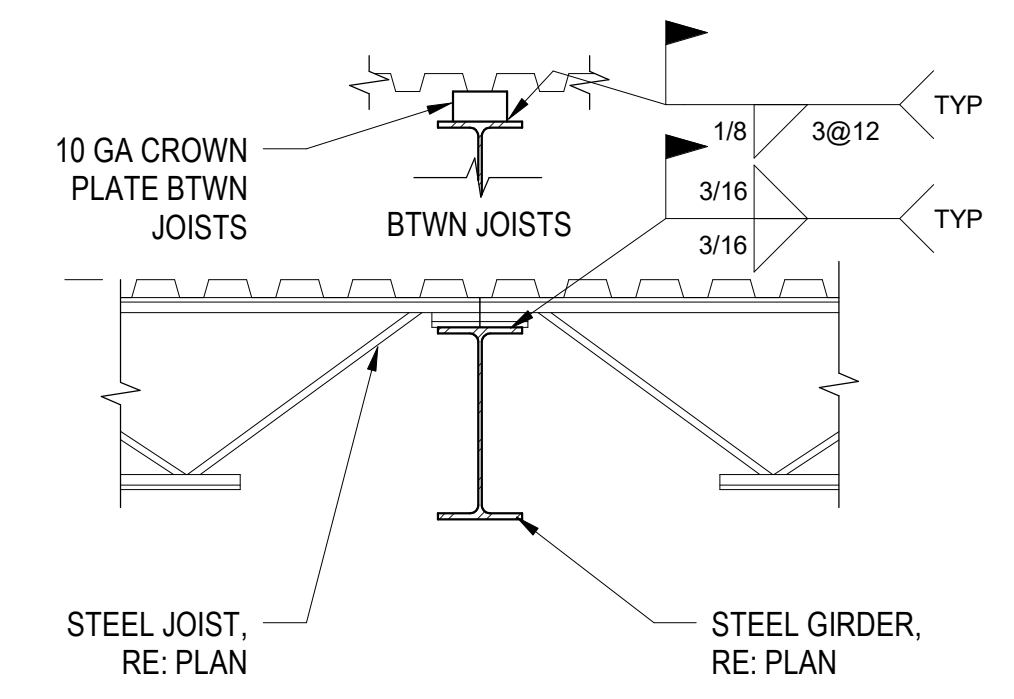

D5 TYP ROOF JOIST ON GIRDER
NTS

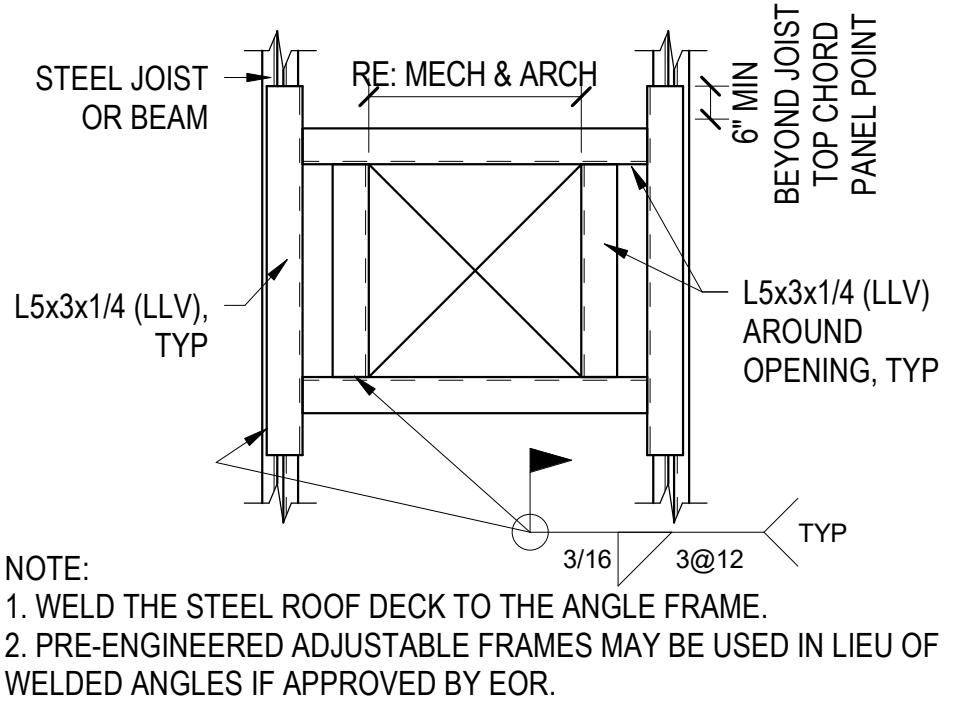

A5 TYP ROOF OPENING SUPPORT
NTS

USE THIS DETAIL FOR HOLES CUTTING INTO MORE THAN:
3 ADJACENT WEBS FOR 6" AND 8" MODULE DECK OR
2 ADJACENT WEBS FOR 12" MODULE DECK

PRIOR TO CONCRETE POUR, SMALL OPENINGS SHOULD BE BLOCKED OUT AND FLOOR DECK LEFT INTACT. HOLES LESS THAN 6" IN DIAMETER AND CUTTING NO MORE THAN 1 WEB NEED NO REINFORCING. AFTER THE CONCRETE HAS CURED, THE BLOCKOUT CAN BE REMOVED AND THE FLOOR DECK IN THE AREA OF THE HOLE REMOVED.

- NOTES:
1. ANGLES SHALL BE PLACED ON TOP OF THE DECK
 2. IF DIMENSION 'A' IS GREATER THAN 4XD1, 4XD2, OR 32" (WHICHEVER IS LARGER), THEN THERE IS NO RESTRICTION ON DIMENSION 'B'.
 3. IF DIMENSION 'B' IS GREATER THAN 4XD1, 4XD2, OR 32" (WHICHEVER IS LARGER), THEN THERE IS NO RESTRICTION ON DIMENSION 'A'.
 4. IF DIMENSIONS 'A' AND 'B' ARE LESS THAN 4XD1, 4XD2, OR 32" (WHICHEVER IS LARGER), THE OPENING GROUP WILL BE CONSIDERED AS A SINGLE HOLE, AND MUST BE REINFORCED AS REQUIRED FOR THE LARGER OPENING.

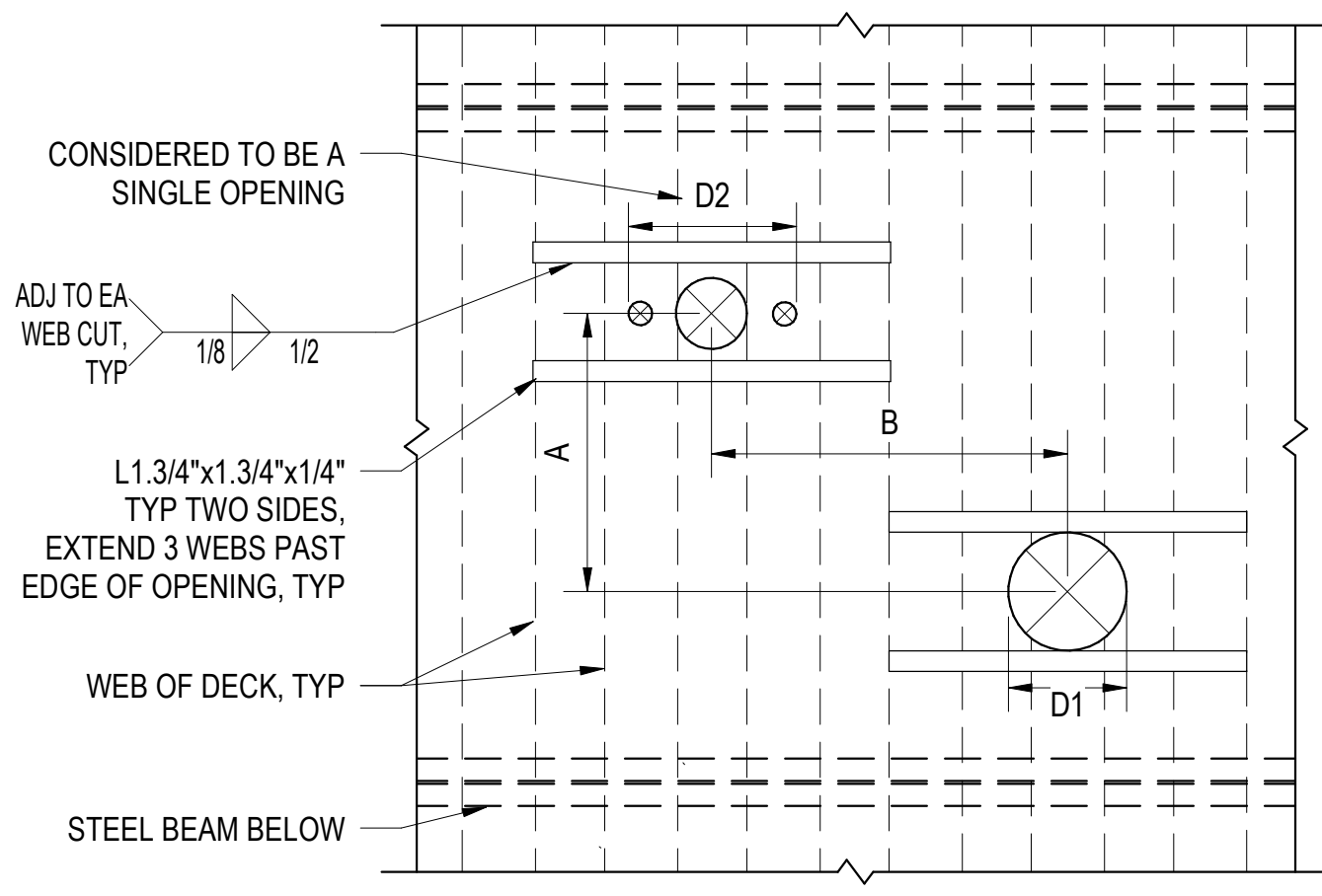

H9 TYPICAL OPENINGS IN COMPOSITE DECK
NTS

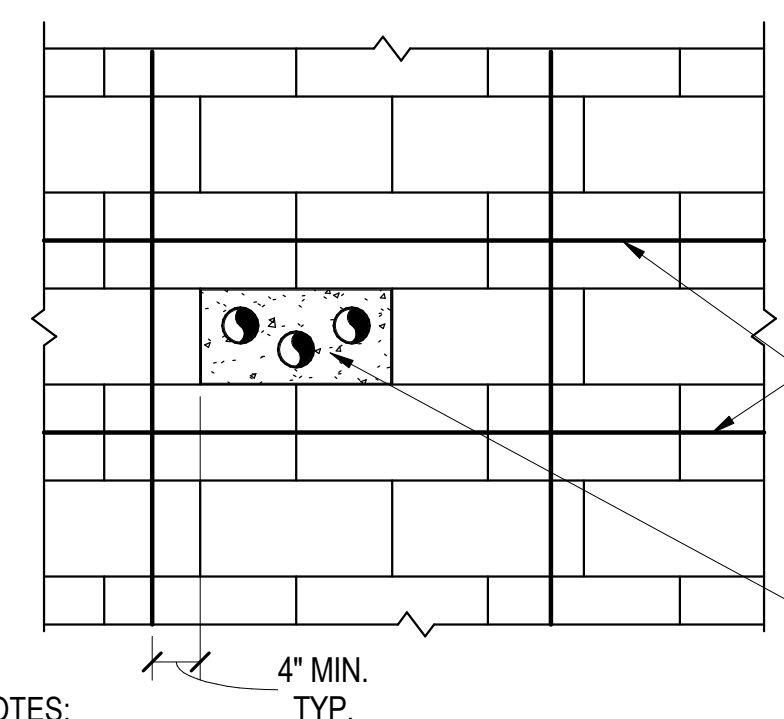

- NOTES:
1. A MAXIMUM OF ONE BLOCK (1'-4") BETWEEN VERTICAL WALL REINFORCING LOCATIONS MAY BE SLEEVED FOR UTILITY PENETRATIONS.
 2. DO NOT PLACE OF ENCROACH UPON CELLS CONTAINING VERTICAL WALL REINFORCING.

D9 PENETRATION THROUGH MASONRY WALL
NTS

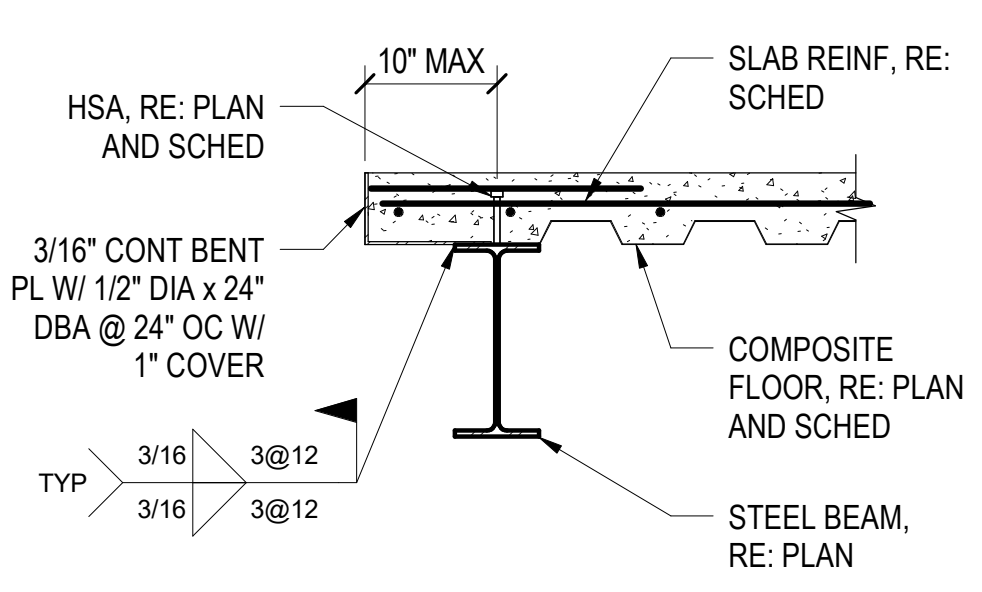

A9 TYP COMPOSITE FLOOR SLAB EDGE
NTS

USE THIS DETAIL FOR LARGER HOLES, RECTANGULAR OR SQUARE

PRIOR TO CONCRETE POUR, SMALL OPENINGS SHOULD BE BLOCKED OUT AND FLOOR DECK LEFT INTACT. HOLES LESS THAN 6" IN DIAMETER AND CUTTING NO MORE THAN 1 WEB NEED NO REINFORCING. AFTER THE CONCRETE HAS CURED, THE BLOCKOUT CAN BE REMOVED AND THE FLOOR DECK IN THE AREA OF THE HOLE REMOVED.

- NOTES:
1. IF THE OPENING OR GROUP OF OPENINGS OCCURS IN ONE DECKING UNIT, THE OPENING OR OPENING GROUP MAY BE CUT PRIOR TO POURING OF CONCRETE.
 2. IF THE OPENING OR GROUP OF OPENINGS CUTS THROUGH TWO DECKING UNITS, THE DECKING SHALL NOT BE CUT UNTIL CONCRETE HAS BEEN PLACED AND CURED. AT THE TIME OF POURING, SUITABLE SLEEVES OR BULKHEADS SHALL BE PLACED AROUND THE OPENING.
 3. WHEN THE MAX DIMENSION OF AN OPENING OR OPENING GROUP EXCEEDS 24", PROVIDE W8X10 HEADER BEAMS BELOW THE DECK AT ALL SIDES.

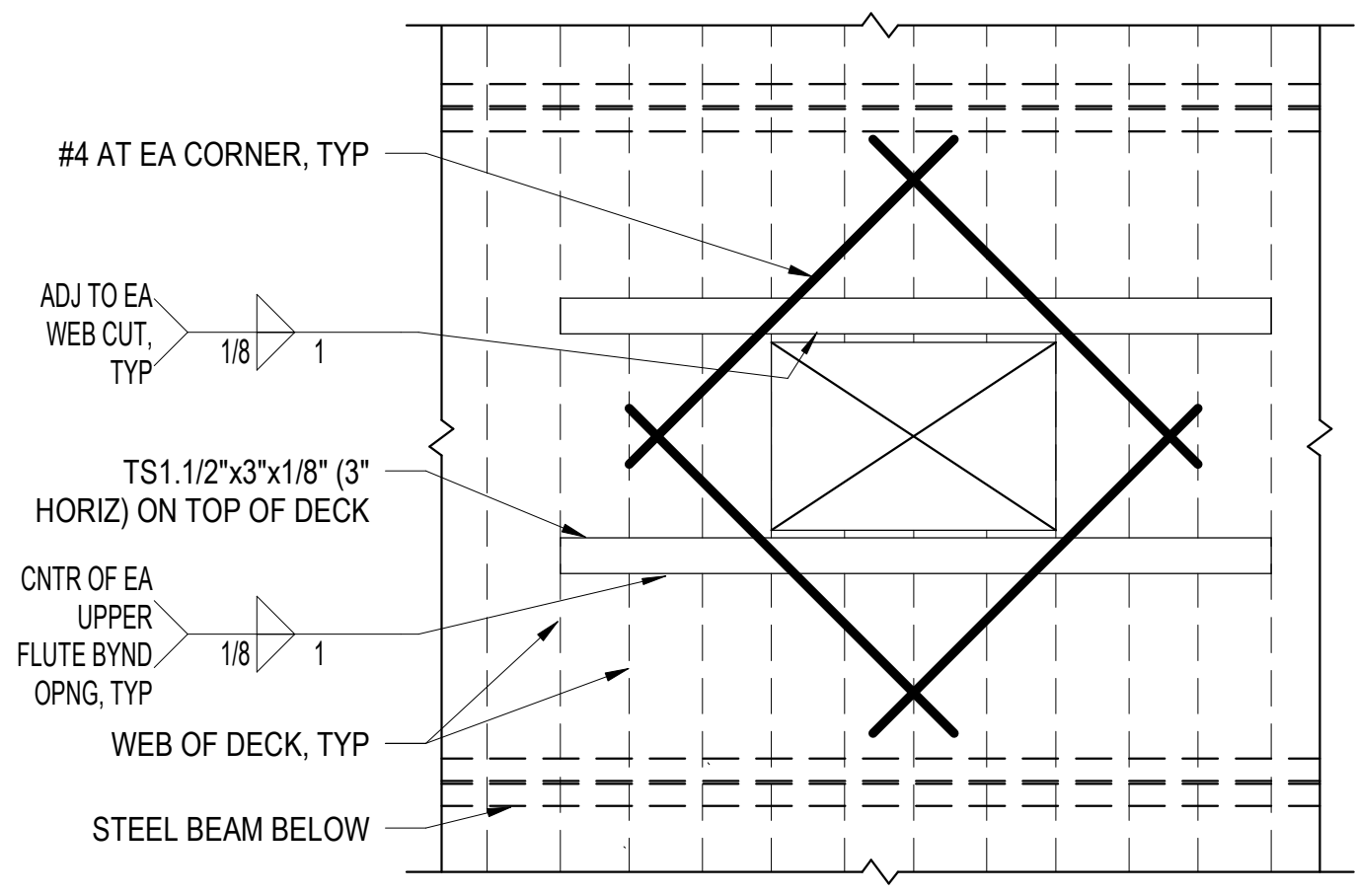

A17 TYP ROOF OPENING < 12" DIAMETER
NTS

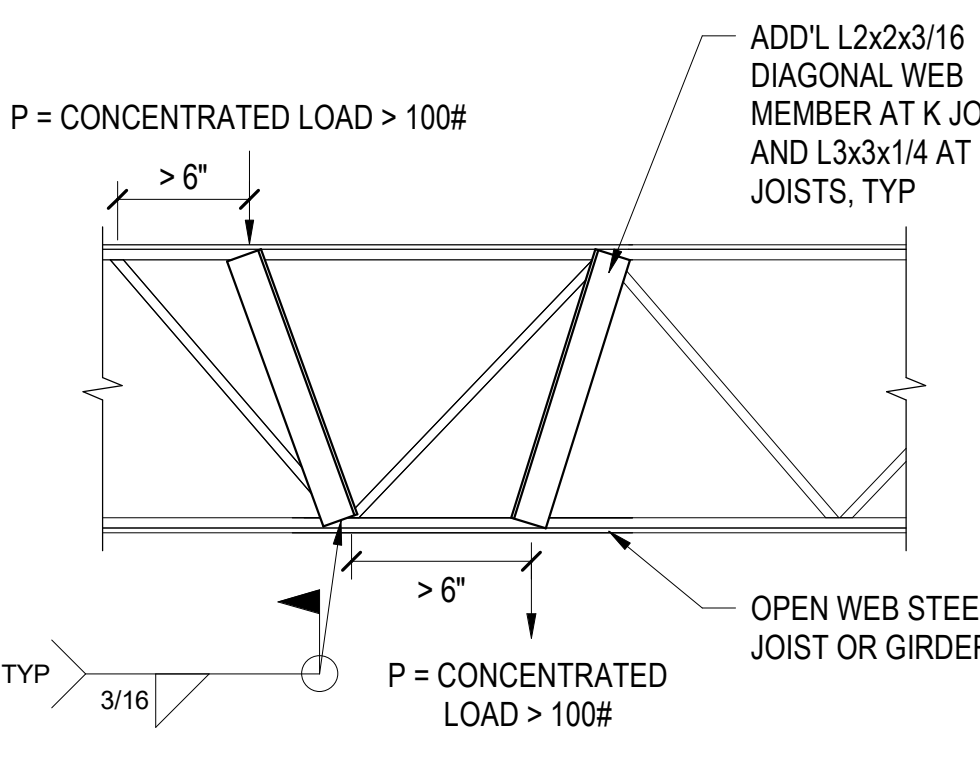

D13 TYP JOIST REINFORCING DETAIL
NTS

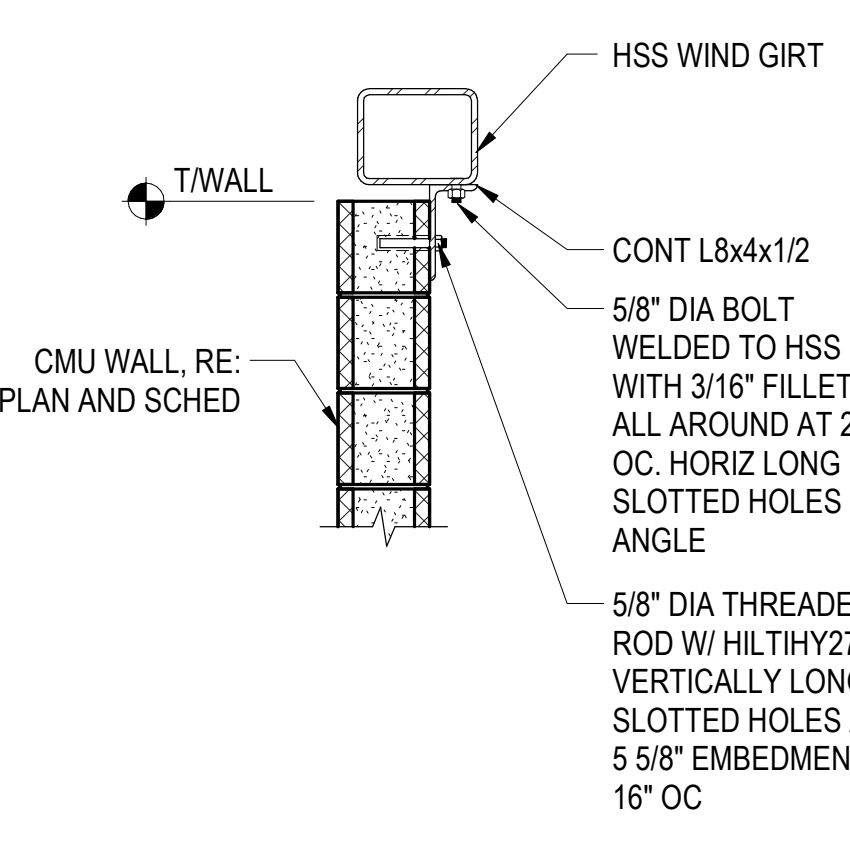

A13 CMU STEEL GIRT
NTS

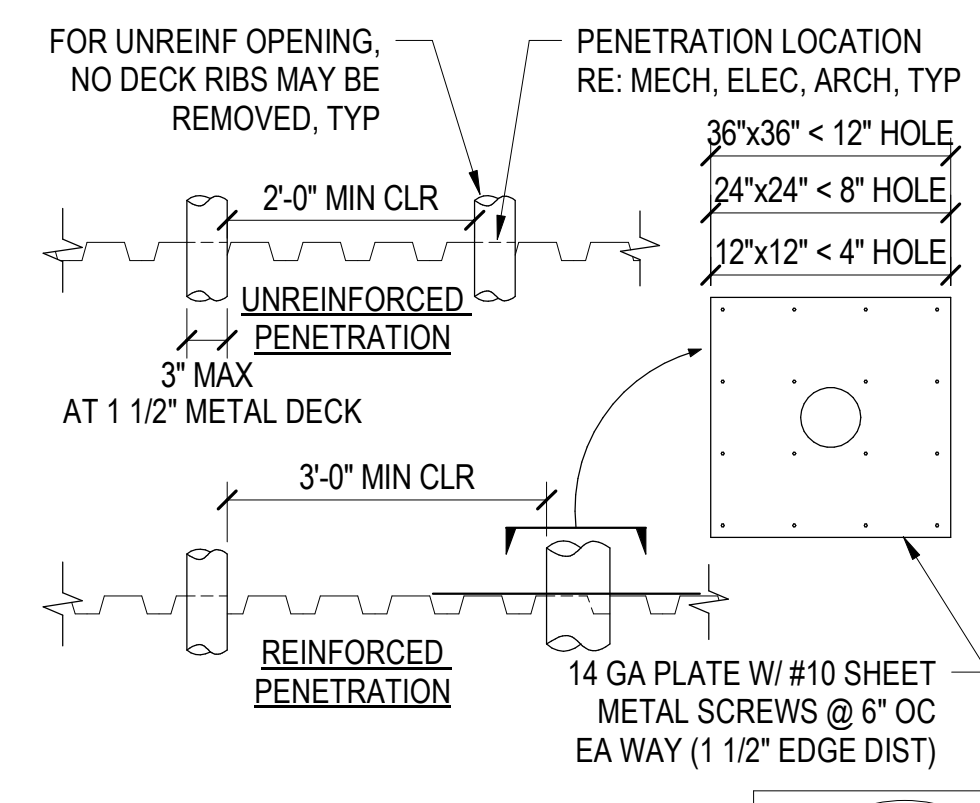

A17 TYP ROOF OPENING < 12" DIAMETER
NTS

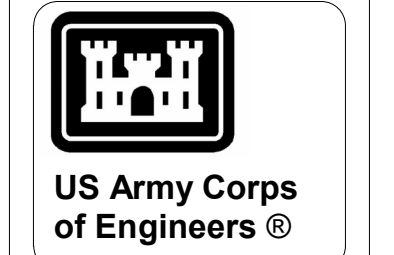

MARK	DESCRIPTION	DATE

ISSUE DATE: NOVEMBER 13, 2025	DESIGNED BY: A. VALENCIA
SOLICITATION NO.: WB12PL25RA0012	DRAWN BY: R. CARLSON
CONTRACT NO.: WB12PL25C0037	CHECKED BY: D. CLAYSON
	SUBMITTED BY: P. PASZCZUK
	SIZE: ANSI D

US ARMY CORPS OF ENGINEERS
LOS ANGELES DISTRICT

KORTE CONSTRUCTION
5700 OAKLAND AVE, SUITE 275
ST. LOUIS, MO 63110

CREECH AIR FORCE BASE, CLARK COUNTY, NV
DISASTER RESILIENCY PROGRAM (DRP) - PHASE 2
494137

FRAMING DETAILS

SHEET ID
S-511

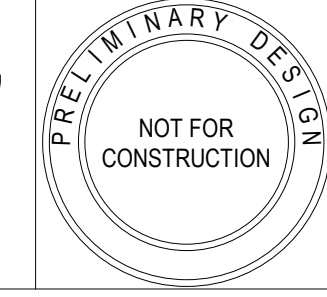

DP-1 95% SUBMISSION

P
N
M
L
K
J
H
G
F
E
D
C
B
A

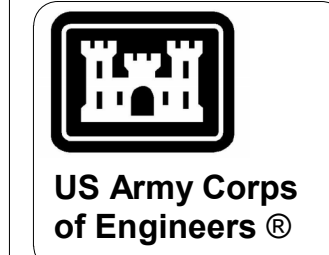

US Army Corps of Engineers®

MARK	DESCRIPTION	DATE

DESIGNED BY: A. VALENCIA	ISSUE DATE: NOVEMBER 13, 2025
DRAWN BY: R. CARLSON	SOLICITATION NO.: W812PL25RA0012
CHECKED BY: D. CLAYSON	CONTRACT NO.: W812PL25C0037
SUBMITTED BY: P. PASZCZYK	SIZE: ANSI D

US ARMY CORPS OF ENGINEERS LOS ANGELES DISTRICT	KORTE CONSTRUCTION 5700 OAKLAND AVE. SUITE 275 ST. LOUIS, MO 63110
--	--

CREECH AIR FORCE BASE, CLARK COUNTY, NV DISASTER RESILIENCY PROGRAM (DRP) - PHASE 2 494137	FRAMING DETAILS
--	-----------------

SHEET ID S-512

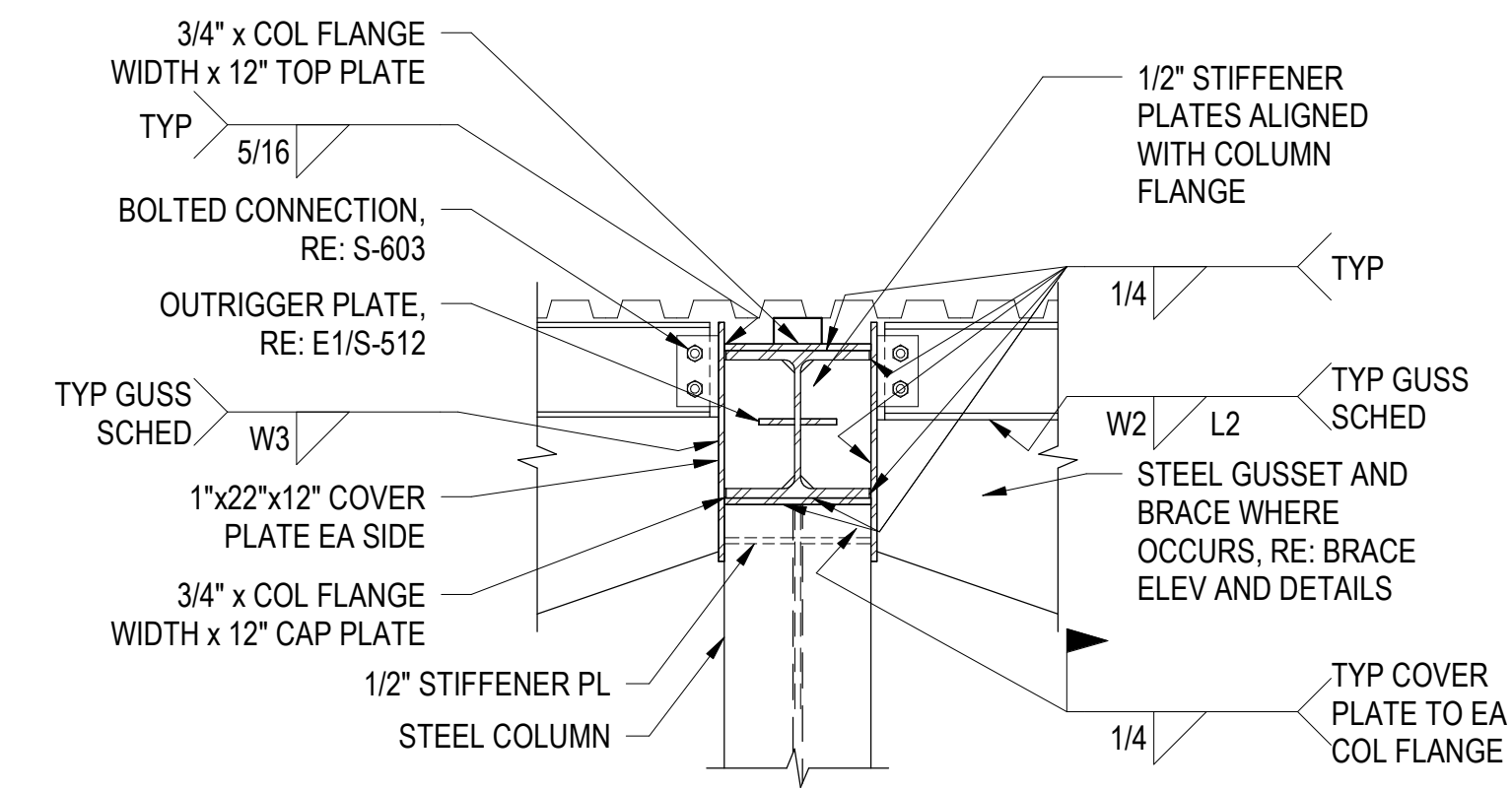

L16 TRUSS TOP CHORD CONNECTION AT COLUMN
NTS REF: S-202

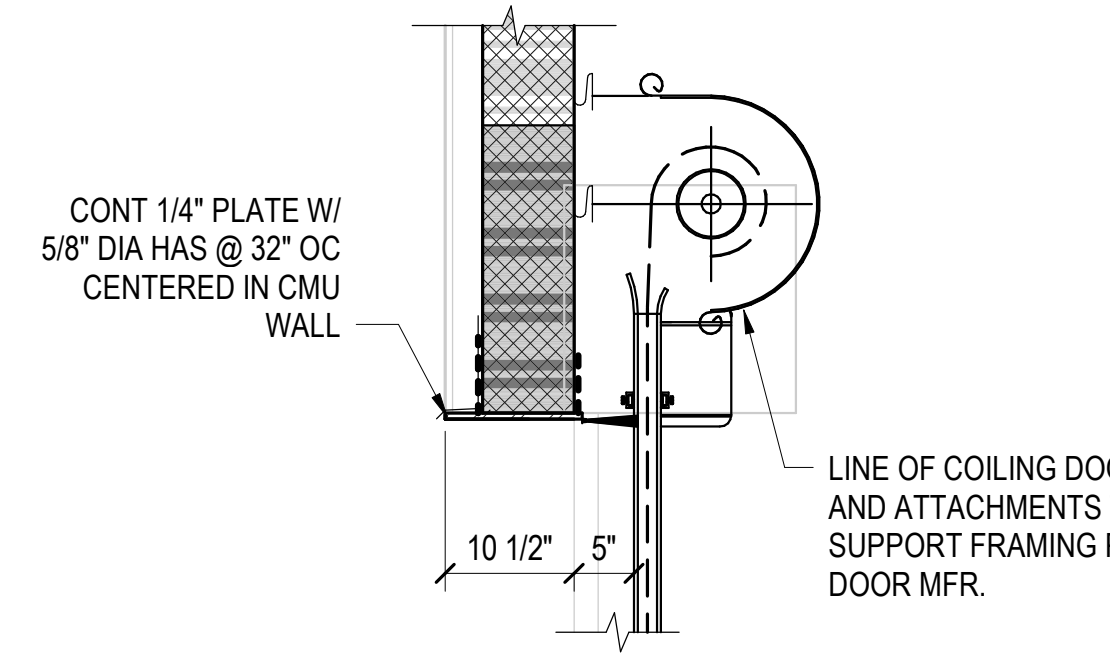

H17 STEEL PANEL HEADER
NTS REF: SF121

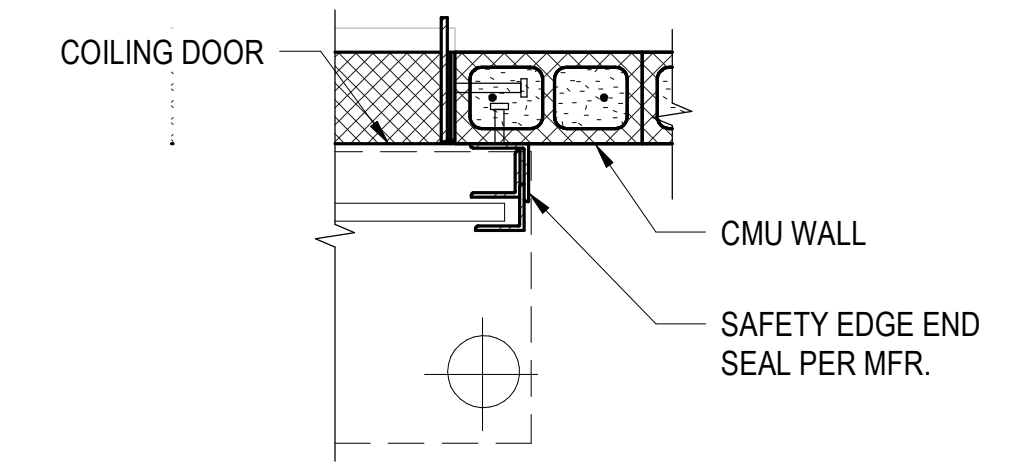

E17 STEEL COILING DOOR JAMB
NTS REF: SF121

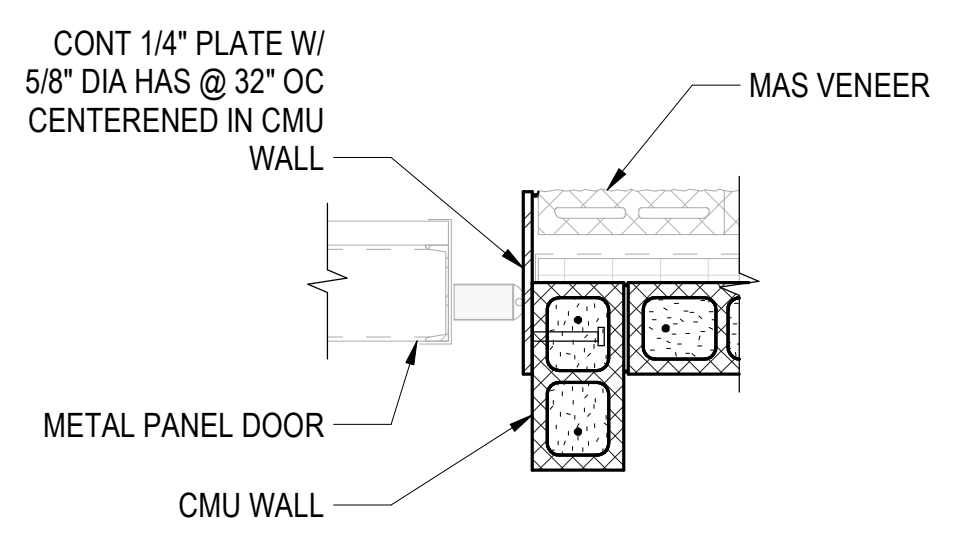

H1 HANGAR DOOR JAMB
NTS

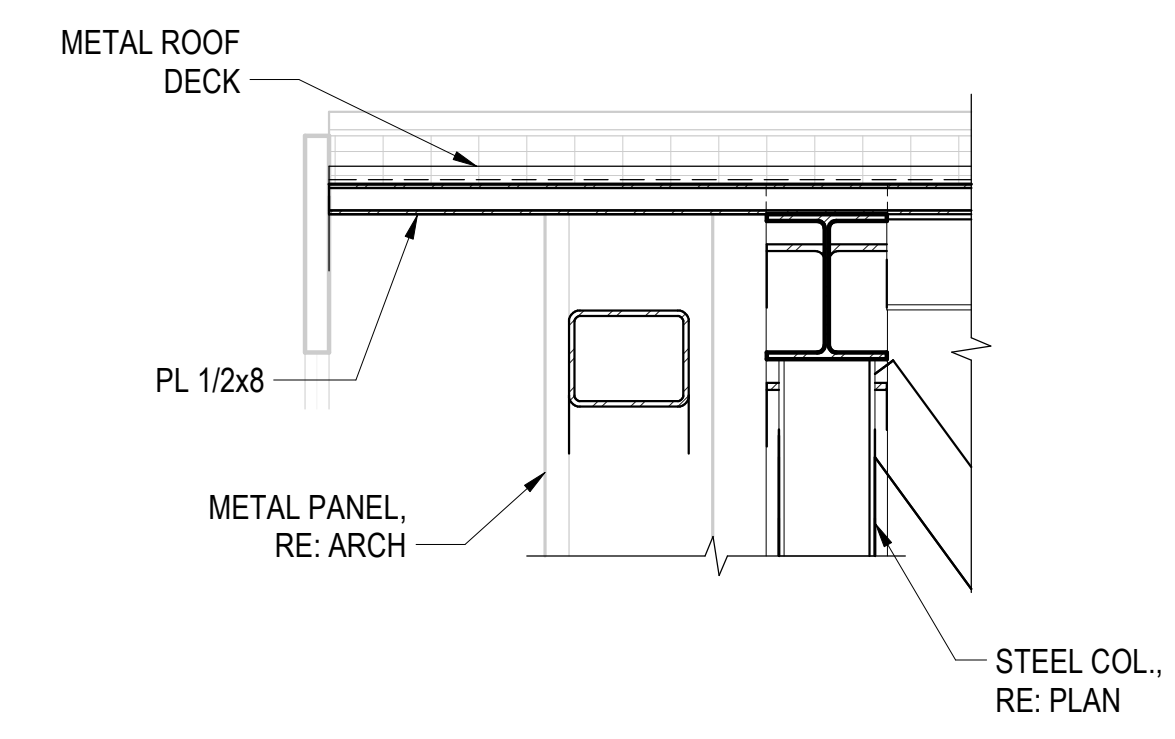

E1 STRUCTURAL CONNECTION
NTS REF: S-211

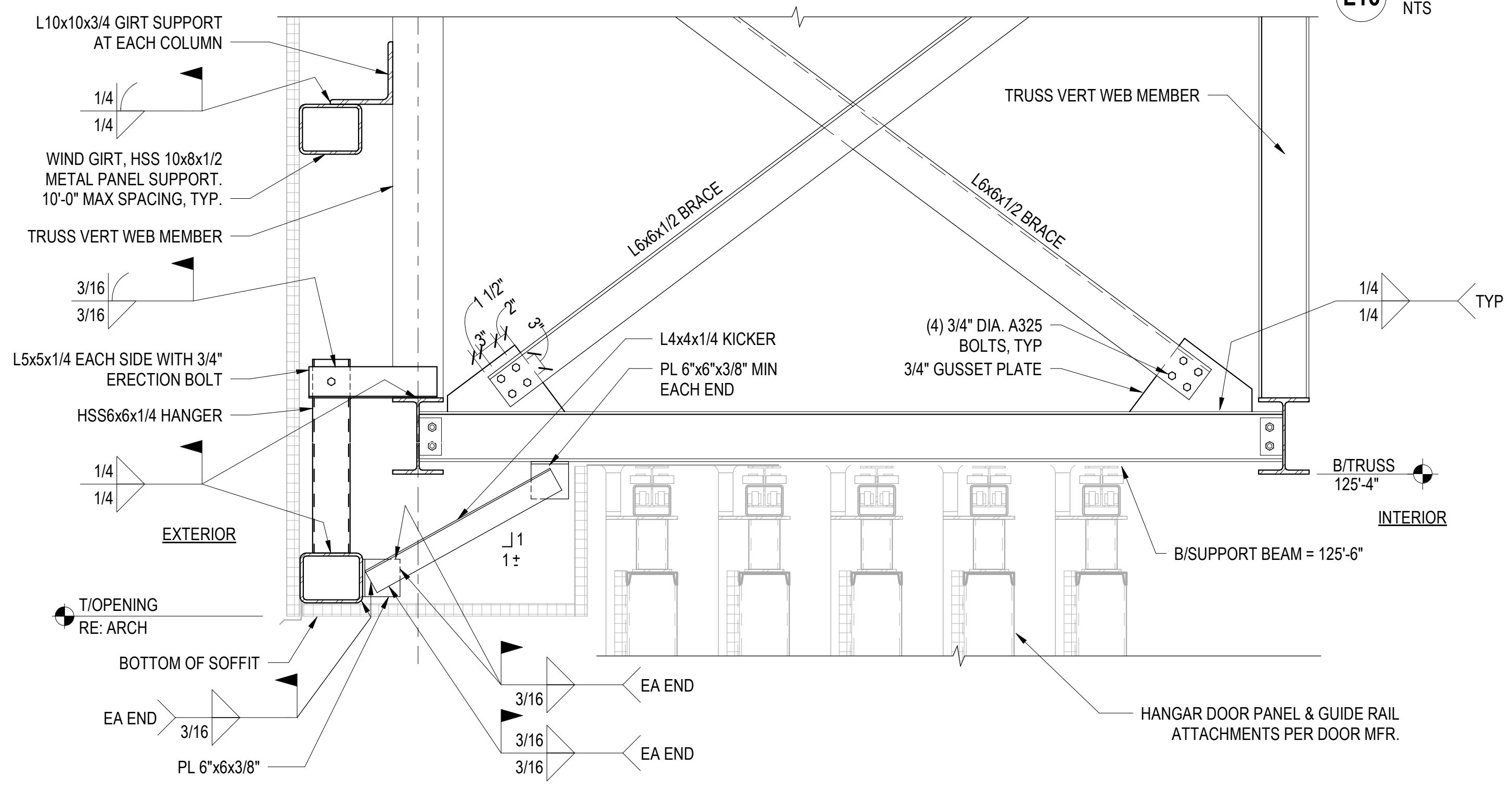

E6 STEEL SLIDING HANGAR DOOR HEADER
NTS

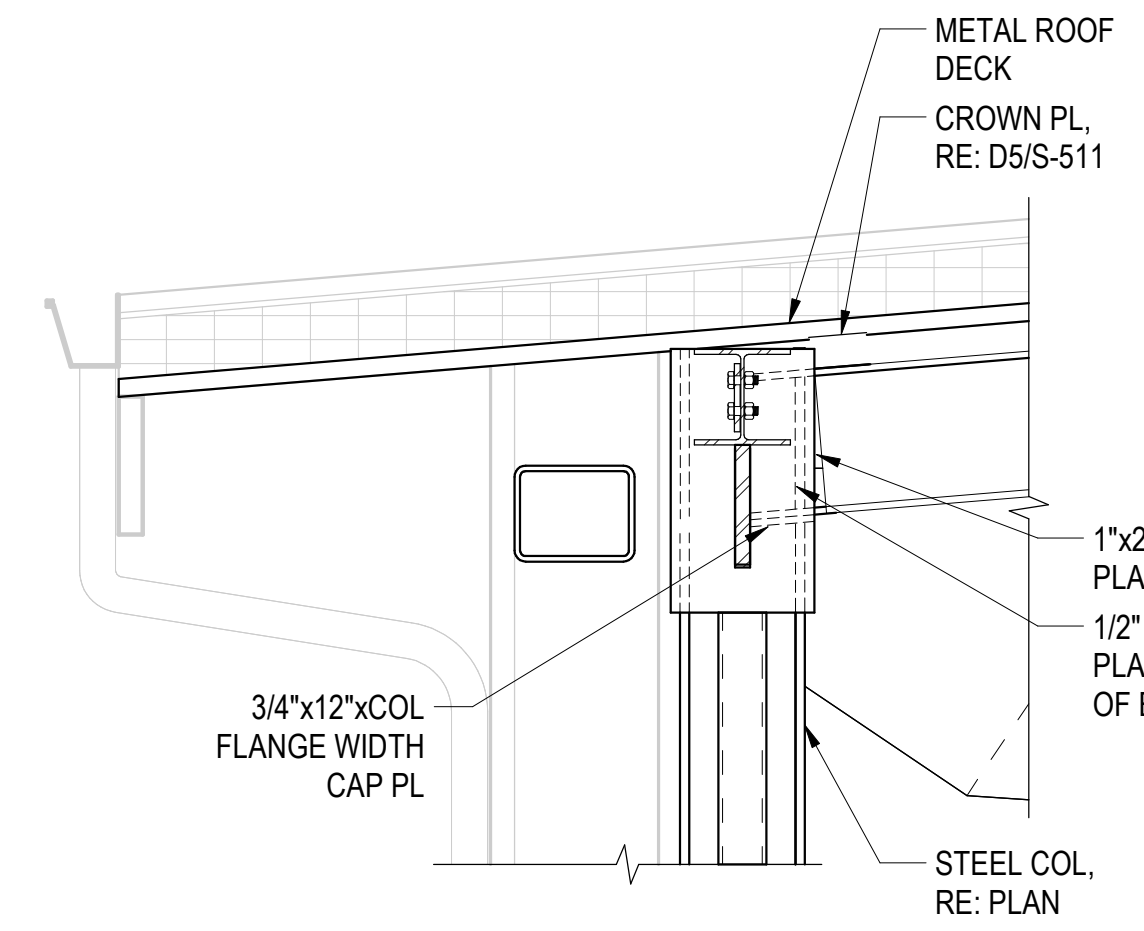

A5 TRUSS TOP CHORD CONN @ METAL WALL
3/4" = 1'-0" REF: S-201

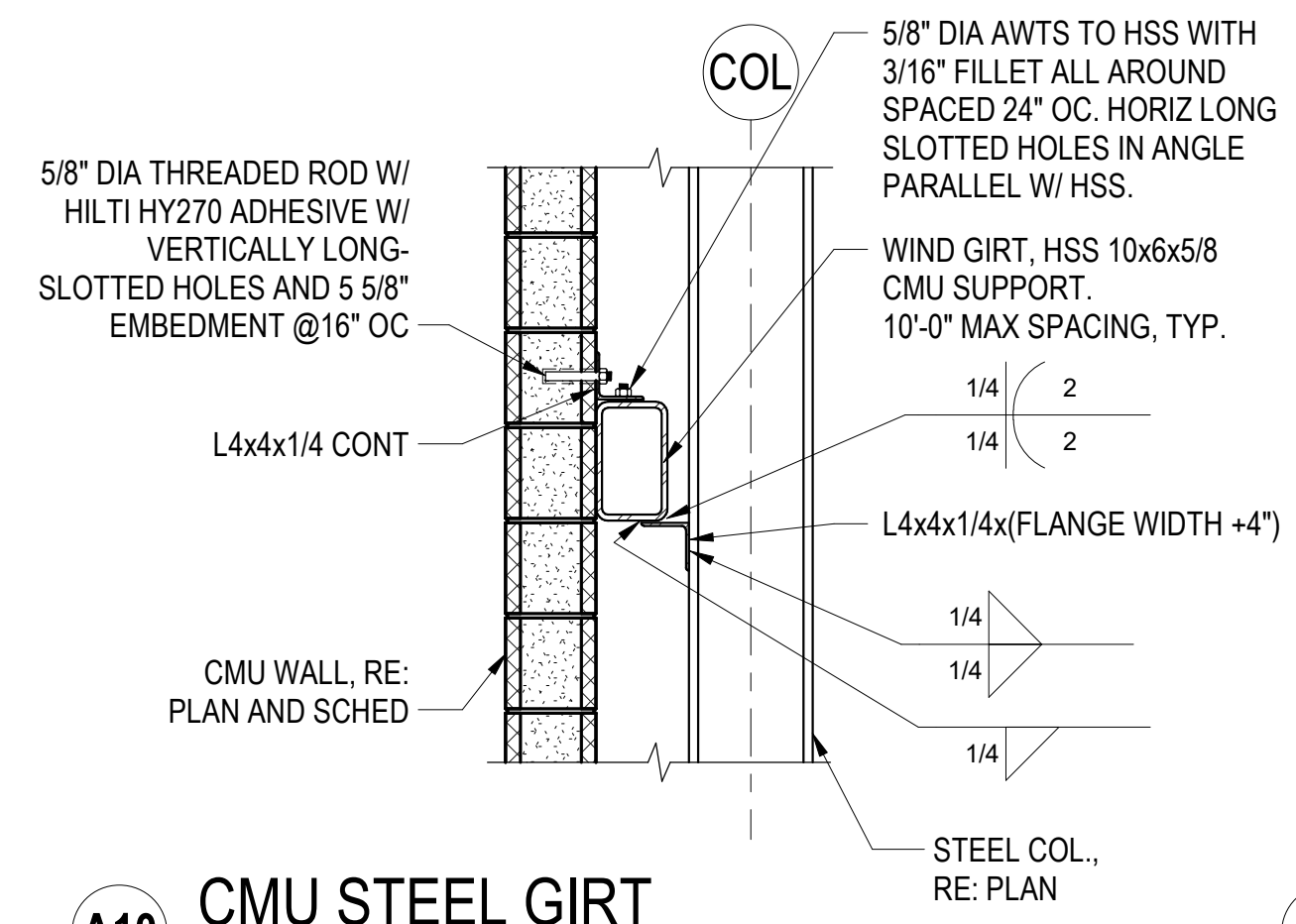

A10 CMU STEEL GIRT
NTS REF: S-301

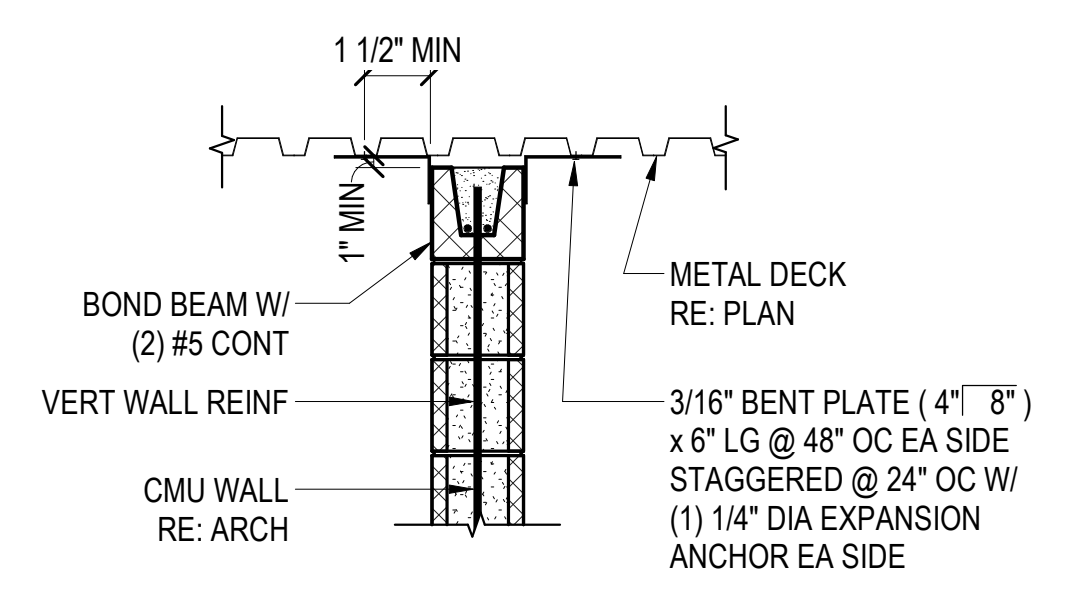

A13 TOP OF CMU WALL TO METAL DECK
NTS

**CONNECTION
DETAILS IN
PROGRESS**

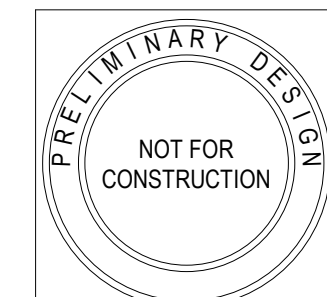

DP-1 95% SUBMISSION

**CONNECTION
DETAILS AND
LATERAL BRACING
DETAILS IN
PROGRESS**

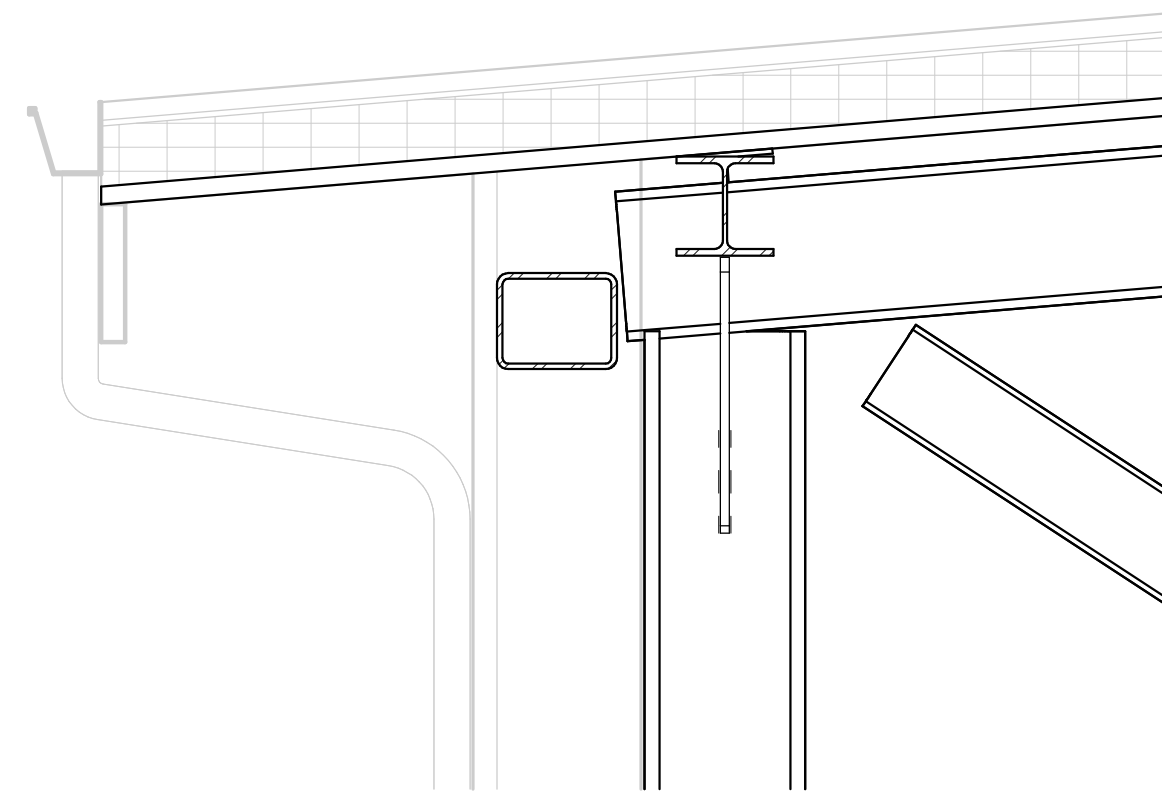

K10 Section 36
3/4" = 1'-0" REF: SF141

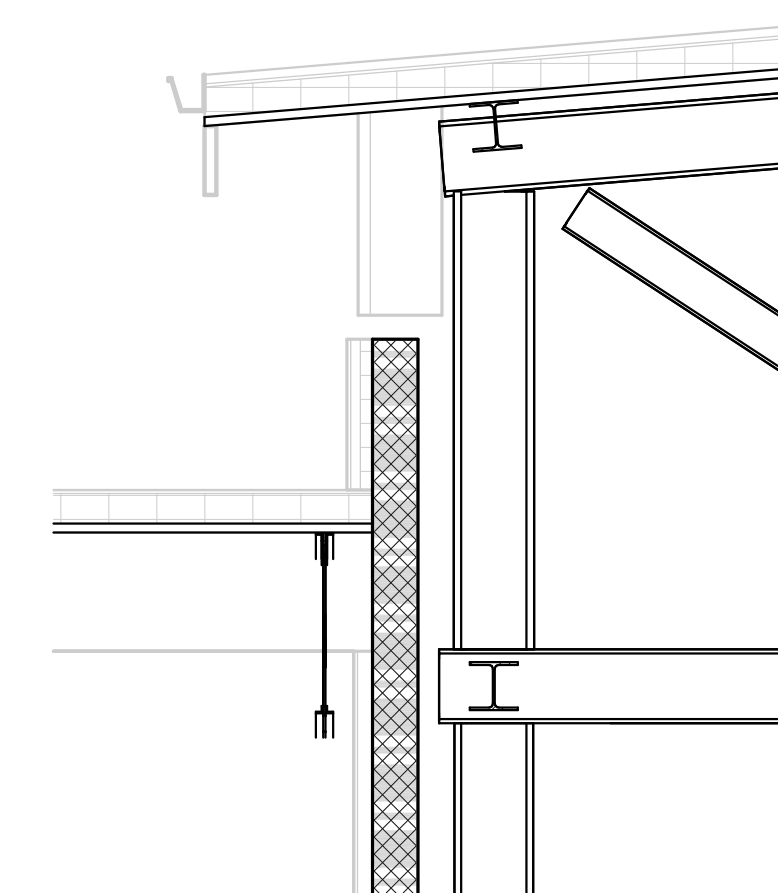

K15 Section 34
3/8" = 1'-0" REF: SF131

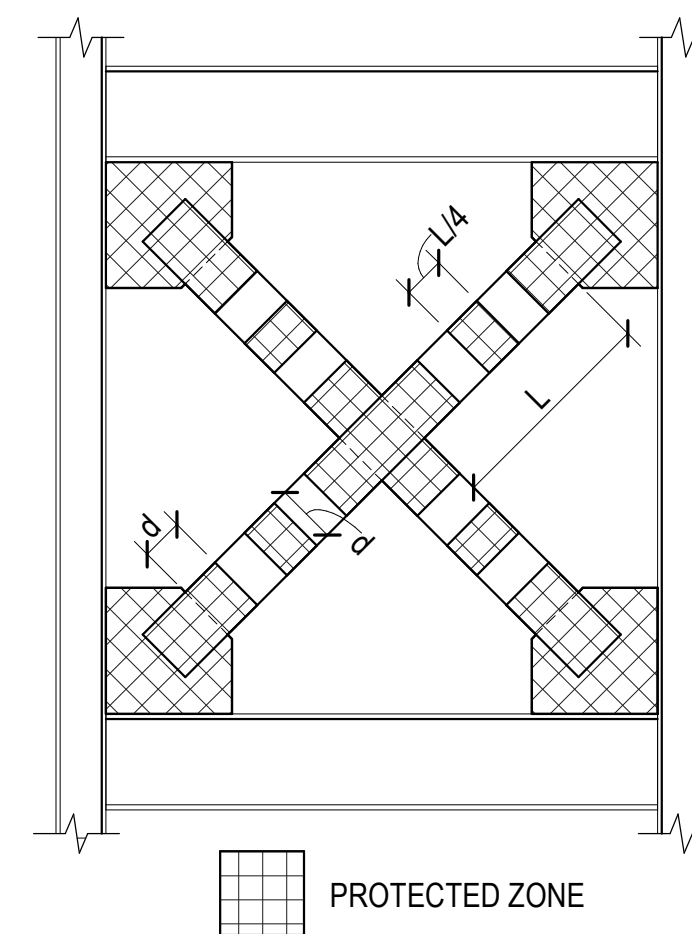

E10 PROTECTED ZONE OF X-BRACED FRAME
NTS

- NOTES:**
- DISCONTINUITIES RESULTING FROM FABRICATION AND ERECTION PROCEDURES AND FROM OTHER ATTACHMENTS ARE PROHIBITED IN THE REGION OF A MEMBER OR A CONNECTION ELEMENT DESIGNATED AS A PROTECTED ZONE.
 - WELDED STEEL HEADED STUD ANCHORS AND OTHER CONNECTIONS ARE PERMITTED IN PROTECTED ZONES.
 - WITHIN THE PROTECTED ZONE, HOLES, TACK WELDS, ERECTION AIDS, AIR-ARC GOUGING, AND UNSPECIFIED THERMAL CUTTING FROM FABRICATION OR ERECTION OPERATIONS SHALL BE REPAIRED AS REQUIRED BY THE ENGINEER OF RECORD (EOR).
 - STEEL HEADED STUD ANCHORS SHALL NOT BE PLACED ON BEAM FLANGE WITHIN THE PROTECTED ZONE.
 - ARC SPOT WELDS AS REQUIRED TO ATTACH DECKING ARE PERMITTED.
 - DECKING ATTACHMENTS THAT PENETRATE THE BEAM FLANGE SHALL NOT BE PLACED ON BEAM FLANGES WITHIN THE PROTECTED ZONE, EXCEPT POWER-ACTUATED FASTENERS UP TO 0.18 IN (4.6 MM) DIAMETER ARE PERMITTED.
 - WELDED, BOLTED, OR SCREWED ATTACHMENTS OR POWER-ACTUATED FASTENERS FOR PERIMETER EDGE ANGLES, EXTERIOR FACADES, PARTITIONS, DUCT WORK, PIPING, OR OTHER CONSTRUCTION SHALL NOT BE PLACED WITHIN THE PROTECTED ZONE. EXCEPTION: OTHER ATTACHMENTS ARE PERMITTED WHERE DESIGNATED OR APPROVED BY THE EOR.
 - PROTECTED ZONES BE PERMANENTLY MARKED BY THE FABRICATOR AND RE-MARKED BY THE OWNER'S DESIGNATED REPRESENTATIVE IF THOSE MARKINGS ARE OBTUSCURED IN THE FIELD, SUCH AS BY APPLICATION OF FIREPROOFING.

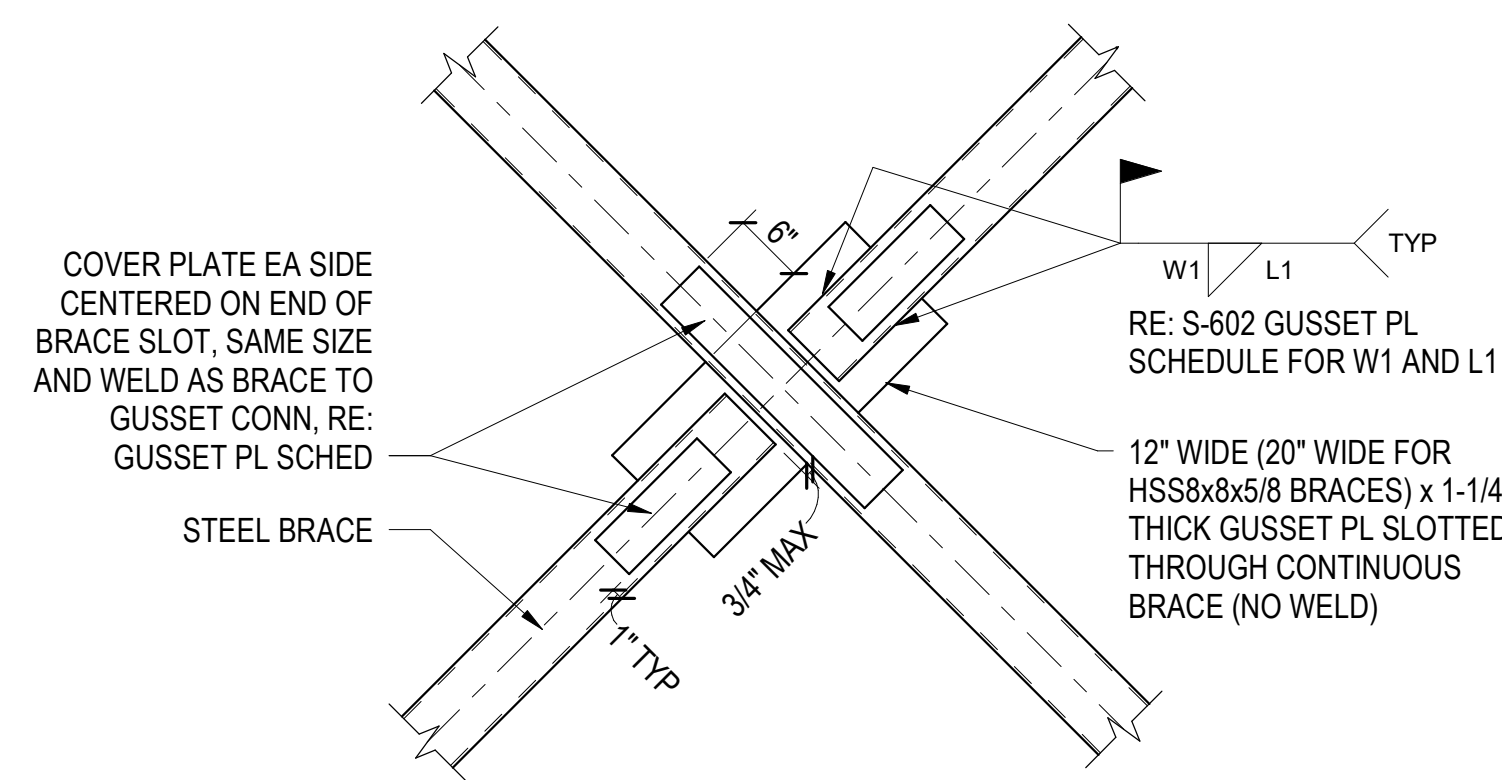

A5 TYP X-BRACE INTERSECTION DETAIL
NTS REF: S-201

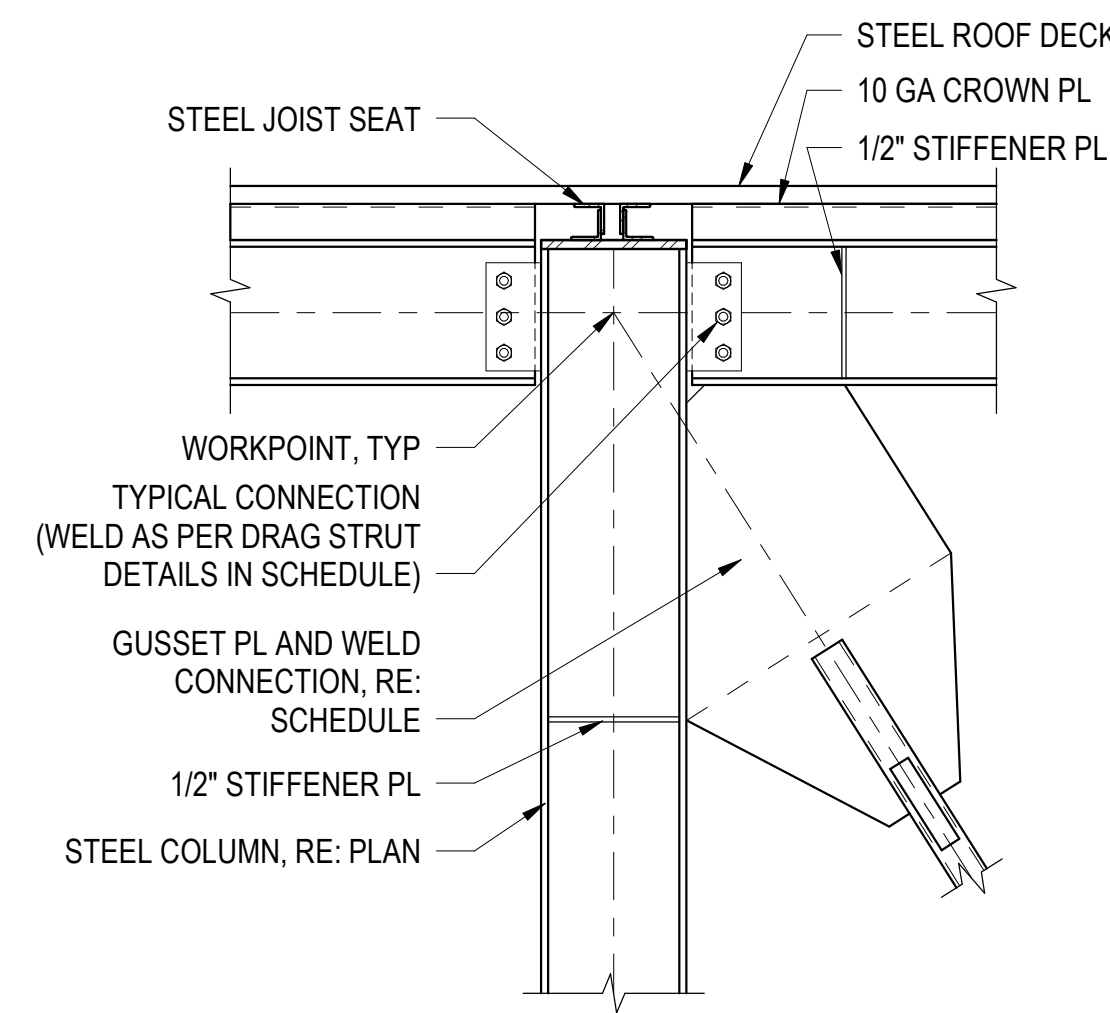

A10 TYP BRACED FRAME ROOF CONNECTION
NTS REF: S-202

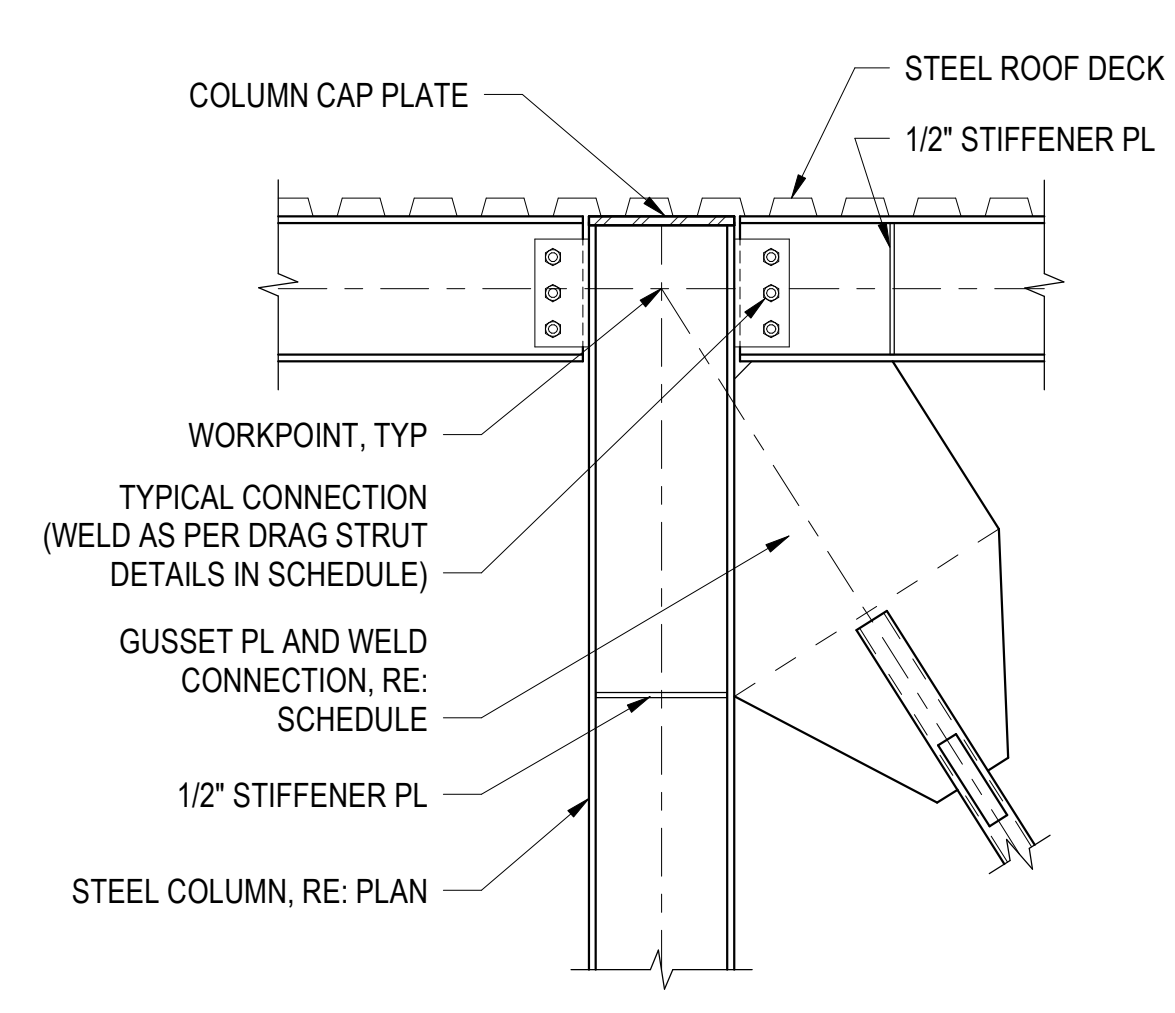

A15 TYP BRACED FRAME ROOF CONNECTION
NTS REF: S-203

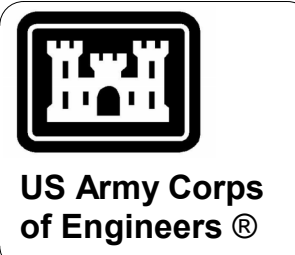

US Army Corps of Engineers®

MARK	DESCRIPTION	DATE

DESIGNED BY: A. VALENCIA	ISSUE DATE: NOVEMBER 13, 2025
DRAWN BY: R. CARLSON	SOLICITATION NO.: W812PL25RA0012
CHECKED BY: D. CLAYSON	CONTRACT NO.: W812PL25C0037
SUBMITTED BY: P. PASZCZUK	SIZE: ANSI D
US ARMY CORPS OF ENGINEERS LOS ANGELES DISTRICT	
KORTE CONSTRUCTION 5700 OAKLAND AVE. SUITE 275 ST. LOUIS, MO 63110	

CREECH AIR FORCE BASE, CLARK COUNTY, NV
DISASTER RESILIENCY PROGRAM (DRP) - PHASE 2
494137
BRACED FRAME DETAILS

SHEET ID
S-521

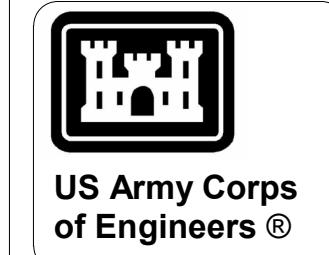

US Army Corps of Engineers®

MARK	DESCRIPTION	DATE

DESIGNED BY: A. VALENCIA	ISSUE DATE: NOVEMBER 13, 2025
DRAWN BY: R. CARLSON	SOLICITATION NO.: W812PL25RA0012
CHECKED BY: D. CLAYSON	CONTRACT NO.:
SUBMITTED BY: P. PASZCZUK	W812PL25C0037
SIZE: ANSI D	

US ARMY CORPS OF ENGINEERS
LOS ANGELES DISTRICT

KORTE CONSTRUCTION
5700 OAKLAND AVE. SUITE 275
ST. LOUIS, MO 63110

CREECH AIR FORCE BASE, CLARK COUNTY, NV
DISASTER RESILIENCY PROGRAM (DRP) - PHASE 2
494137

TRUSS CONNECTION DETAILS

SHEET ID
S-531

DP-1 95% SUBMISSION

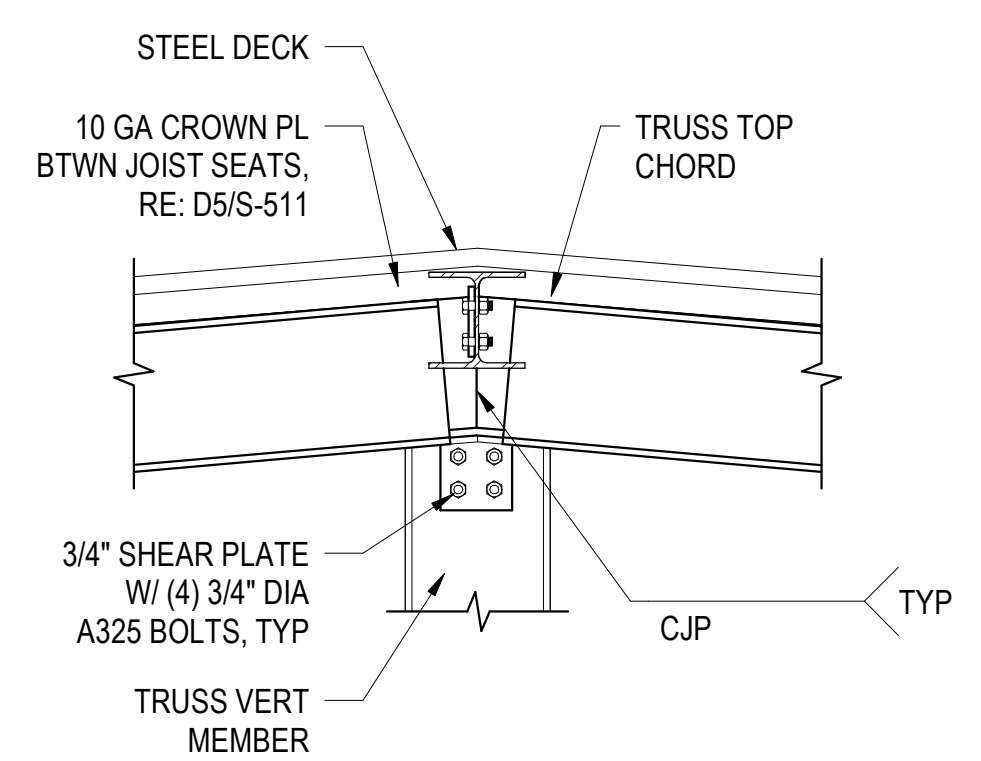

L6 TRUSS RIDGE
3/4" = 1'-0" REF: S-211

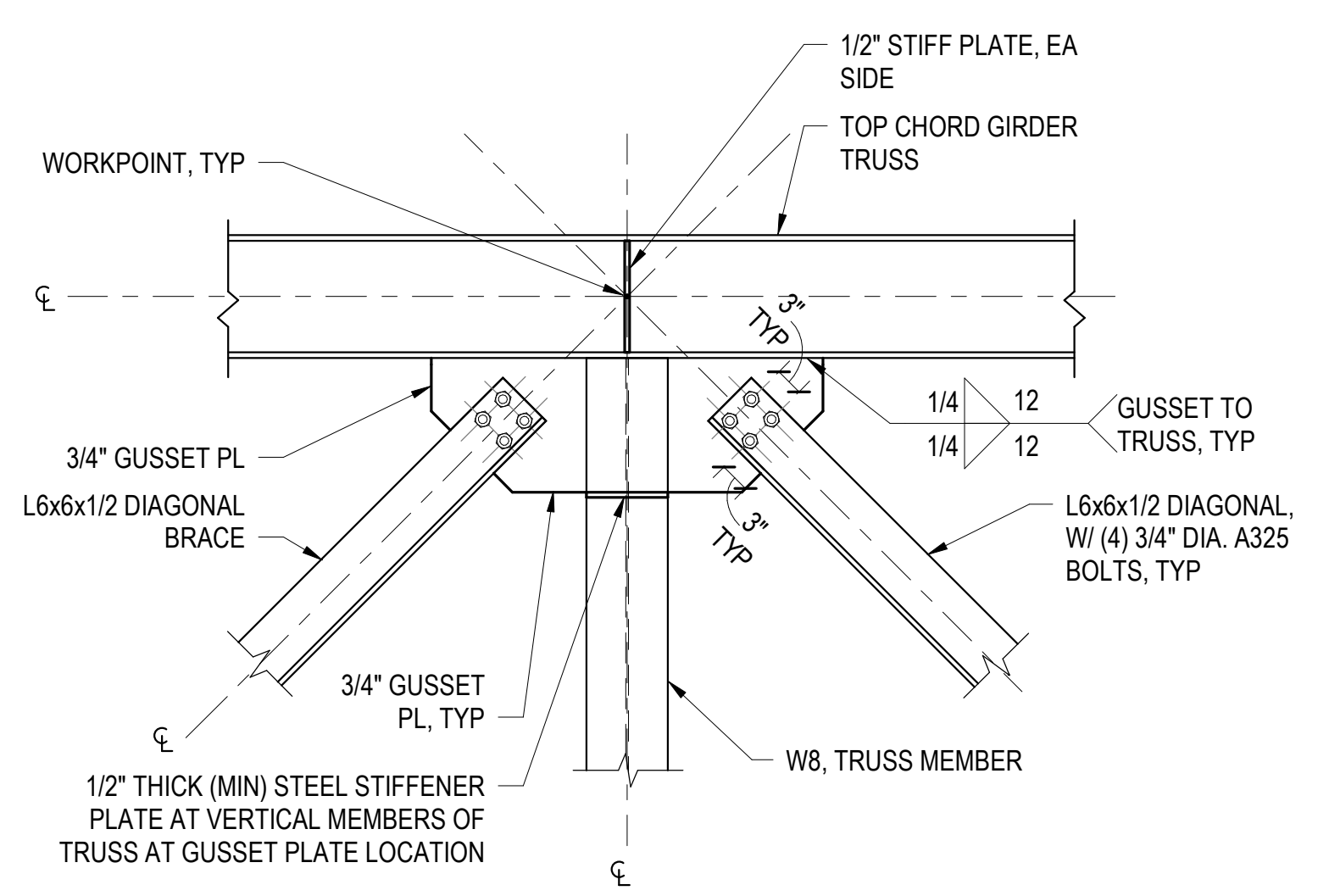

L10 TOP CHORD TRUSS GIRDER TO BRACE CONNECTION
NTS REF: S-213

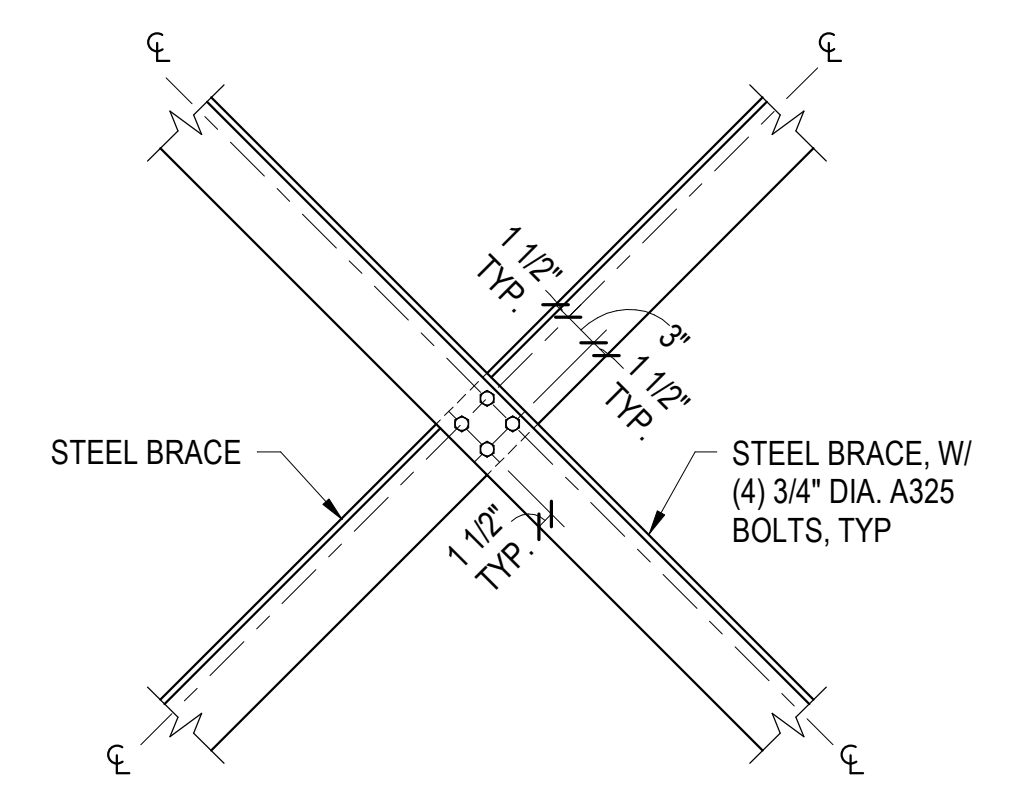

L16 CROSS BRACING AT GIRDER TRUSS
NTS REF: S-213

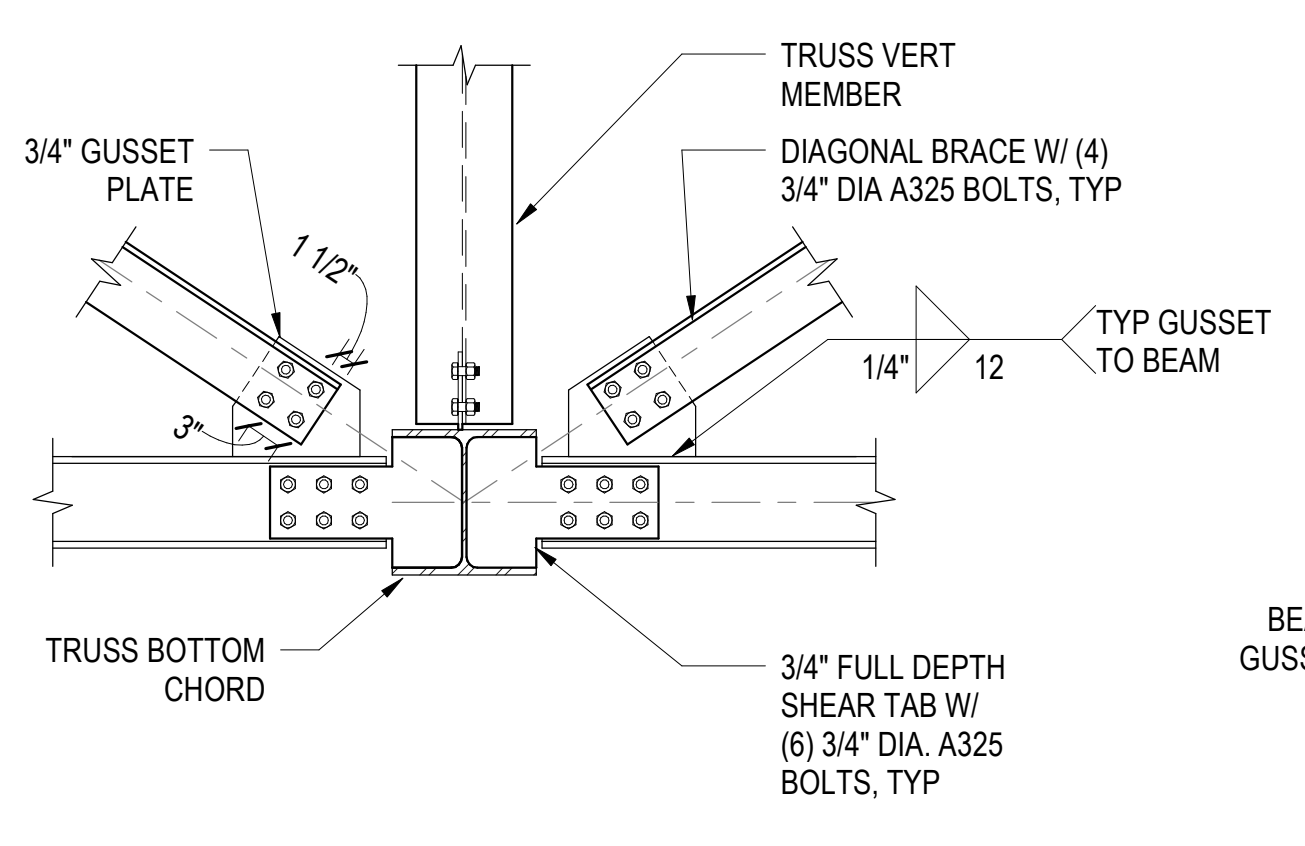

F1 DIAGONAL BRACE ATTACHED TO TRUSS BOT CHORD
NTS REF: S-213

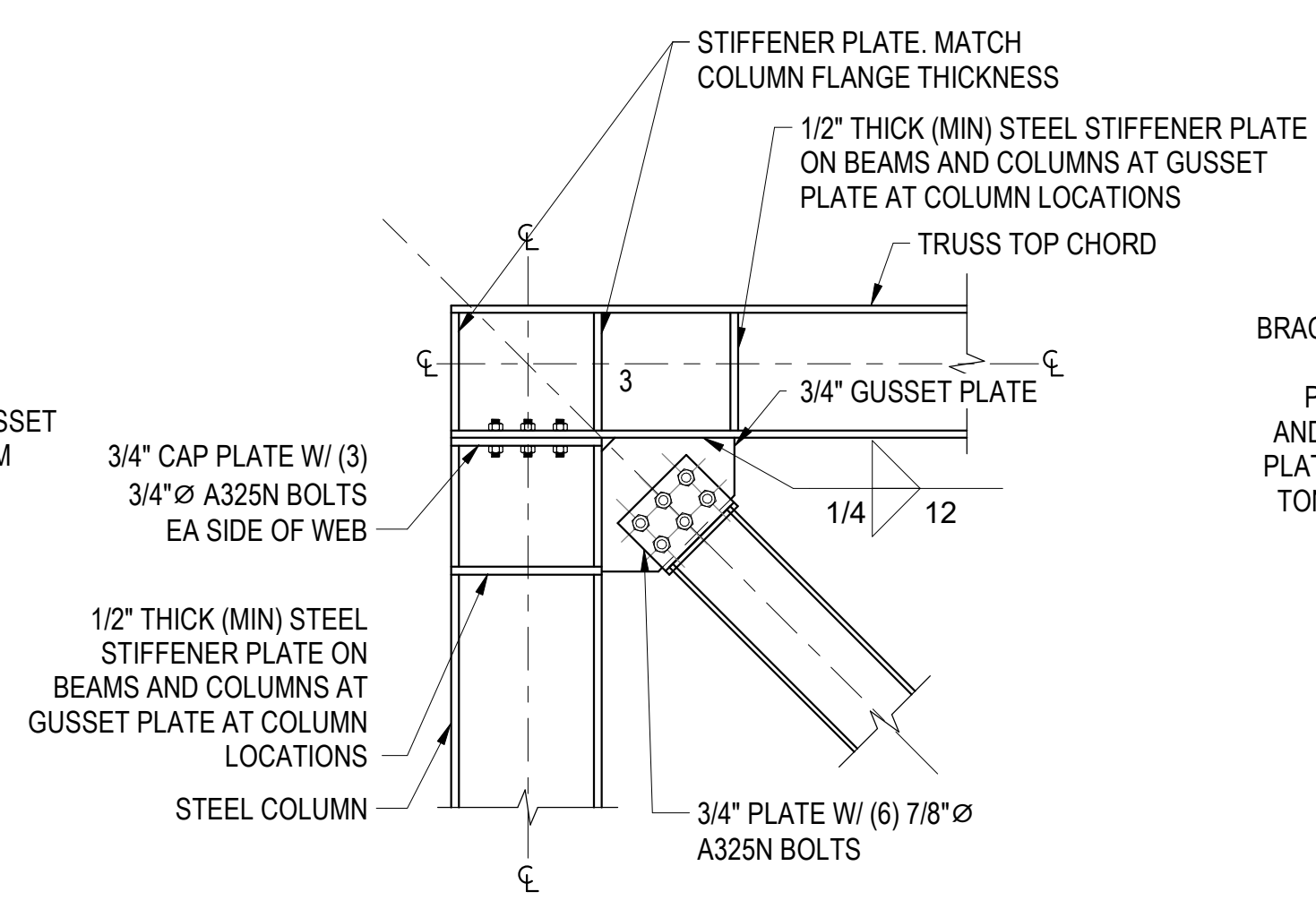

F6 TRUSS TOP CHORD AT STEEL COLUMN
NTS REF: S-211

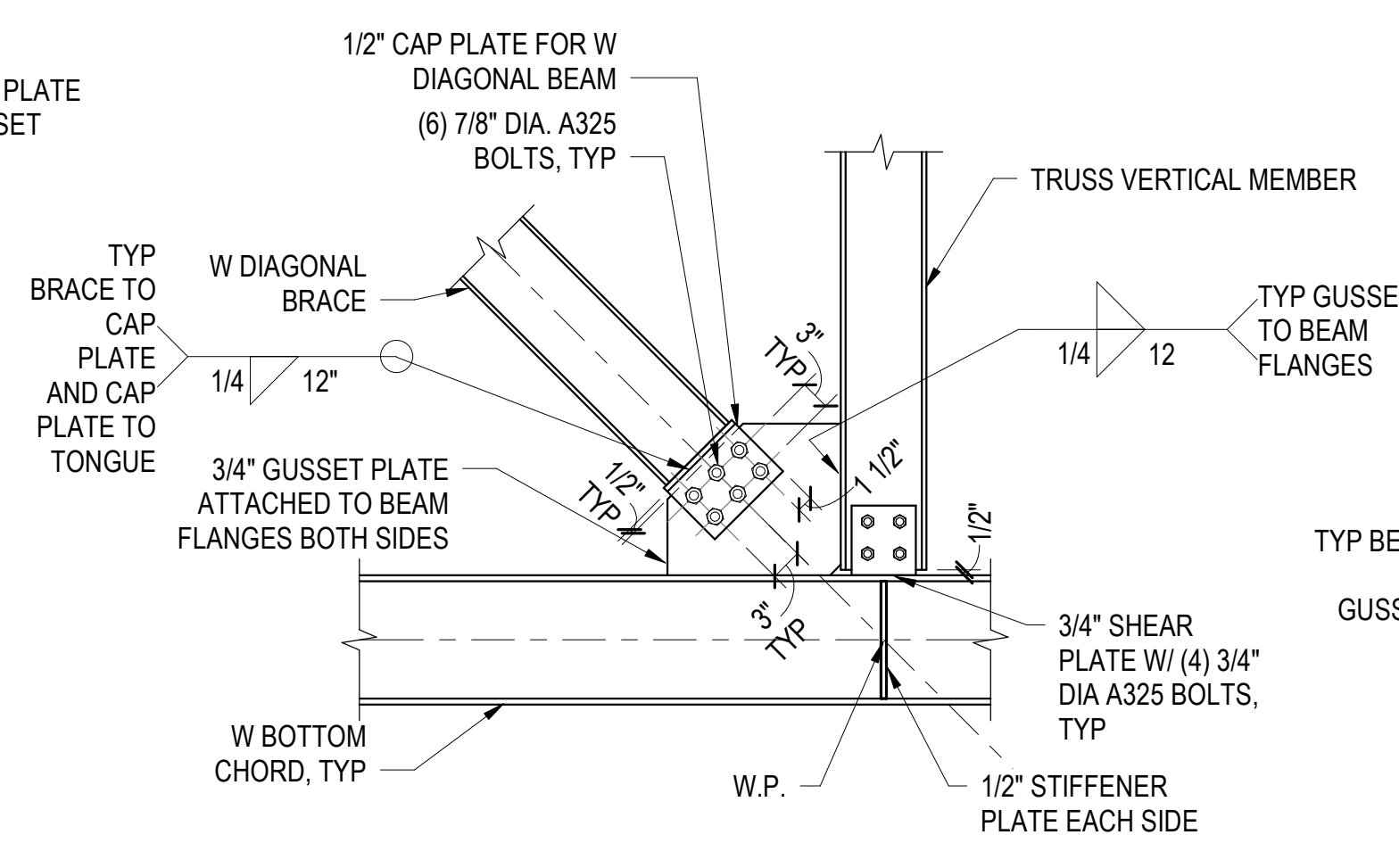

F10 TRUSS BOTTOM CHORD PANEL POINT
NTS REF: S-211

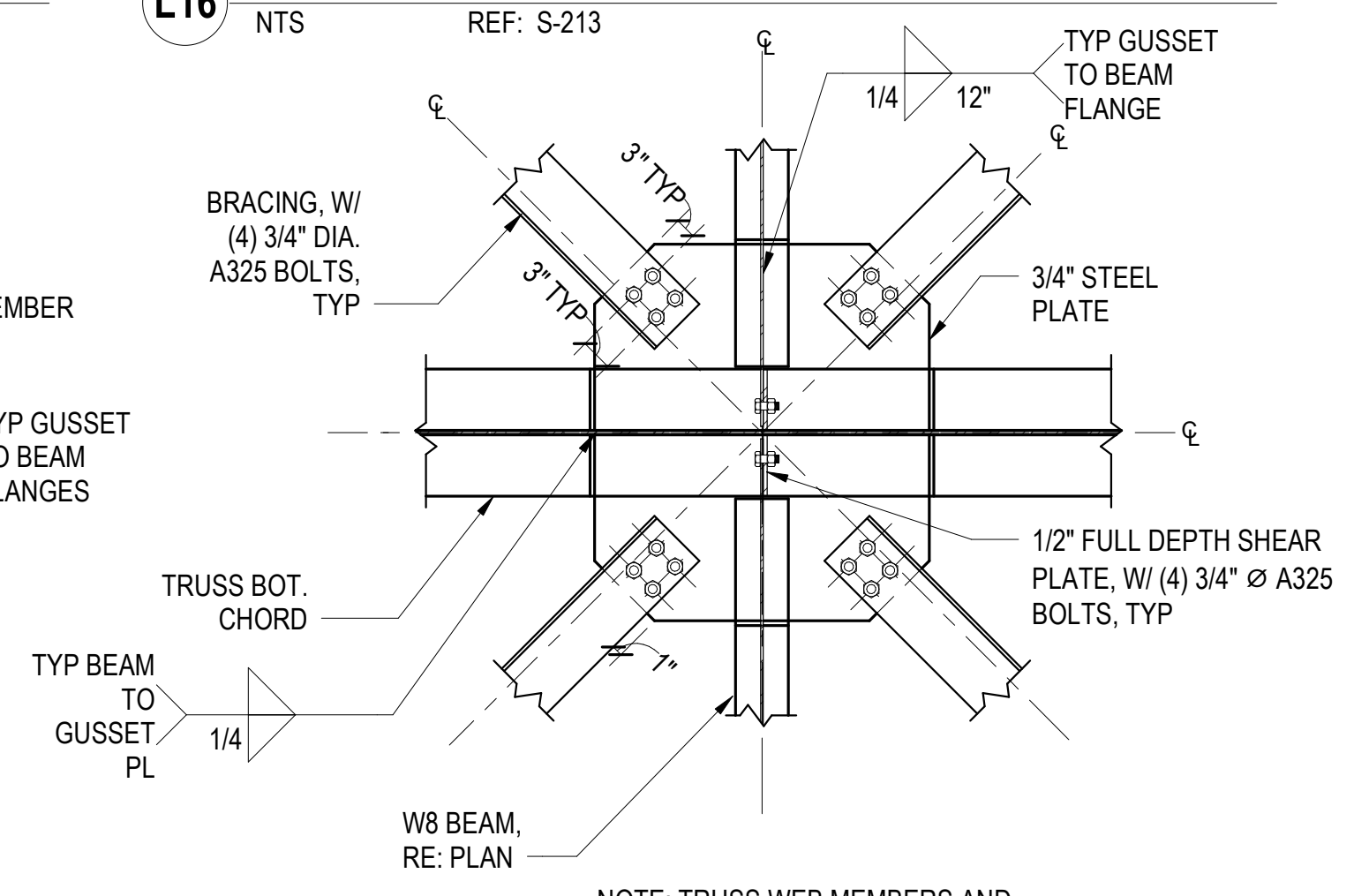

F15 PLAN - TYPICAL HORIZONTAL BOTTOM CHORD BRACING
NTS

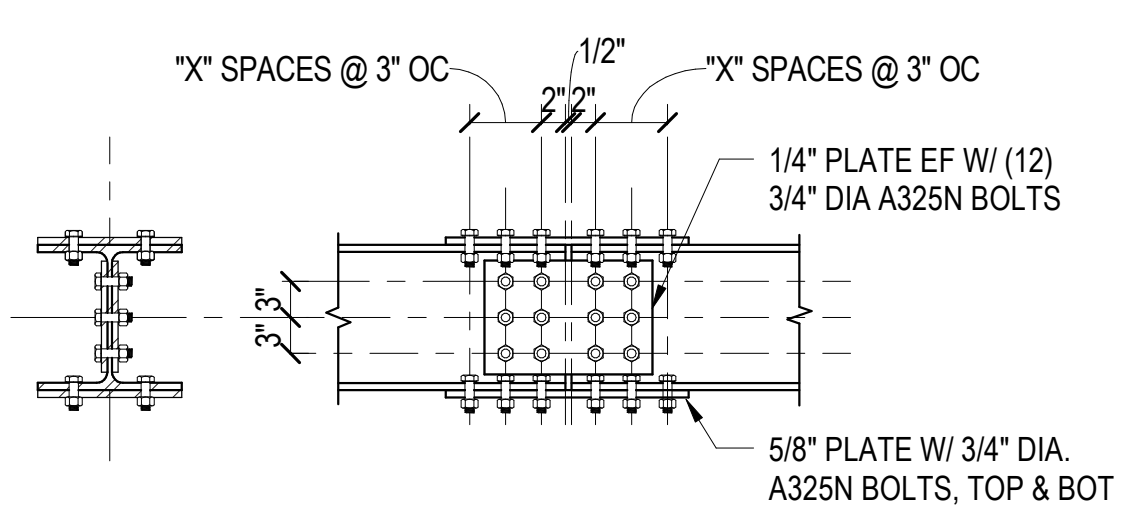

A1 TRUSS CHORD SPLICE DETAIL
NTS

W12x72 TO W12x65: X = 4
W12x65 TO W12x58: X = 3
W12x50 TO W12x45: X = 4
W12x45 TO W12x40: X = 3

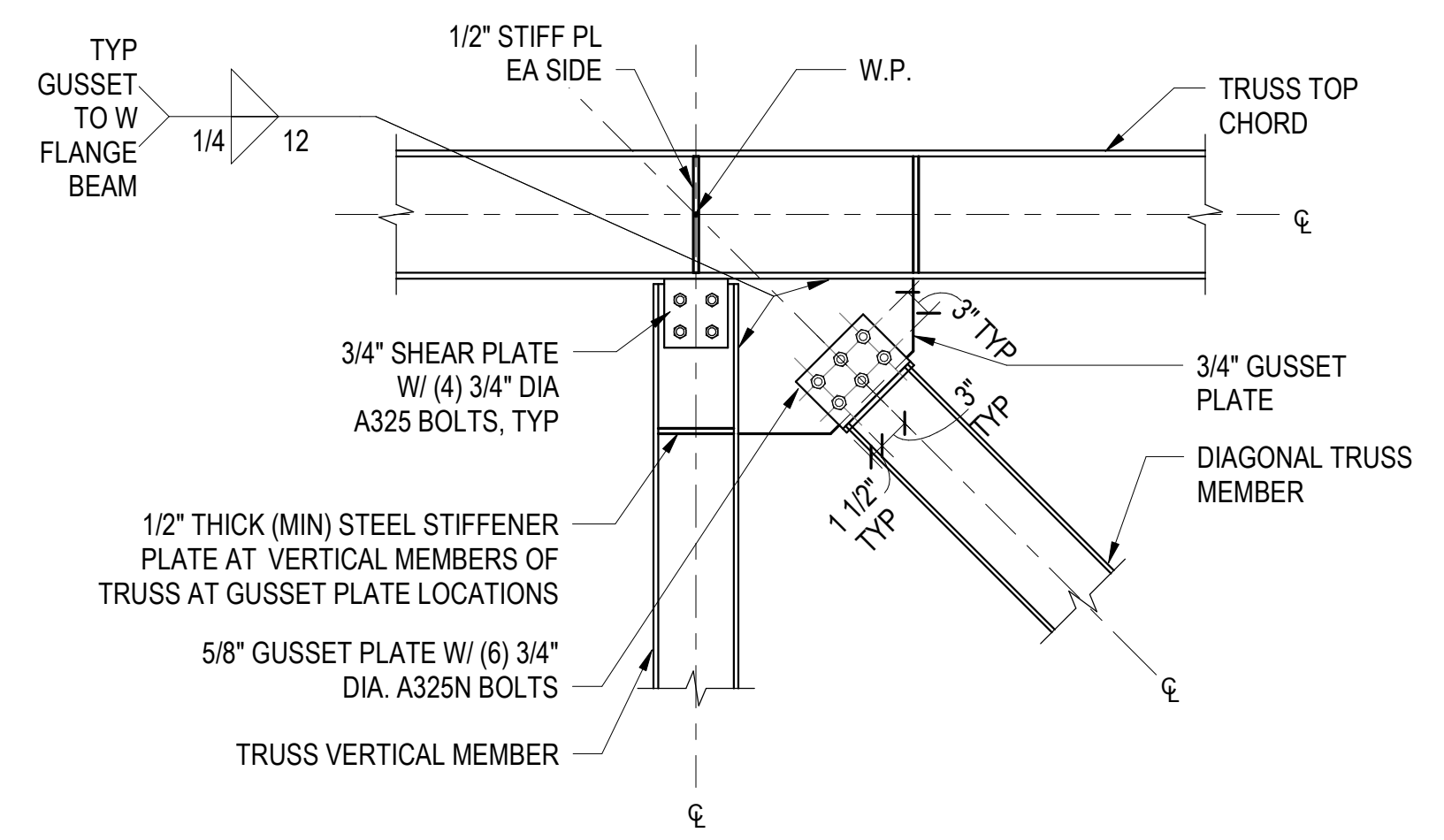

A9 TRUSS TOP CHORD PANEL POINT DETAIL
NTS

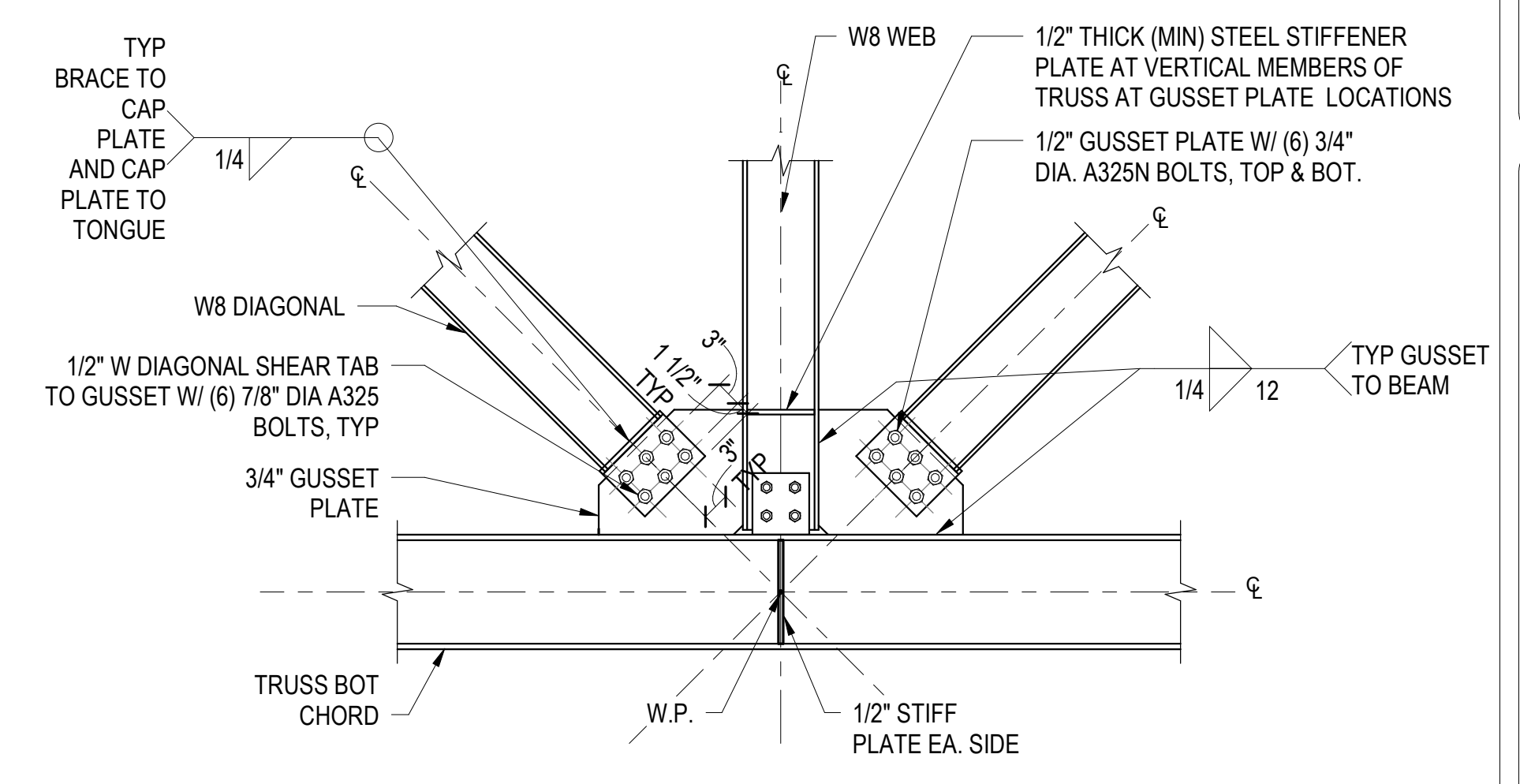

A15 TRUSS BOTTOM CHORD PANEL POINT DETAIL
NTS REF: S-211

STEEL BRACED FRAME COLUMN & BASE PLATE SCHEDULE

COLUMN MARK	Structural Shape	BASE PLATE						ANCHOR ROD		SHEAR LUG		NOTES
		TYPE	THICKNESS	"M" DIM	"N" DIM	"A" DIM	"P" DIM	DIA.	EMBED	THICKNESS	DEPTH	
SC1	W10x68	LWC	1 7/8"	48"	20"	2 1/2"	30"	1 1/2"	28"	2 3/4"	8 1/2"	GR. 105 ANCHORS
SC2	W10x68	LWB	1 3/4"	48"	20"	2 1/2"	N/A	1 1/2"	28"	2 3/4"	8 1/2"	GR. 105 ANCHORS
SC3	W12x120	WA	3/4"	14"	14"	2"	N/A	3/4"	12"	N/A	N/A	
SC4	W12x136	LWA	1 7/8"	45"	20"	2 1/2"	N/A	1 1/2"	28"	2 3/4"	8 1/2"	GR. 105 ANCHORS
SC5	HSS6x6x1/4	HB	3/4"	12"	8"	1 1/2"	N/A	3/4"	9"	N/A	N/A	
SC6	HSS8x8x1/2	HA	3/4"	14"	14"	1 1/2"	N/A	3/4"	9"	N/A	N/A	
SC7	HSS10x10x1/2	HA	3/4"	16"	16"	1 1/2"	N/A	3/4"	9"	N/A	N/A	
SC8	HSS12x12x5/8	HA	3/4"	18"	18"	1 1/2"	N/A	1"	12"	N/A	N/A	

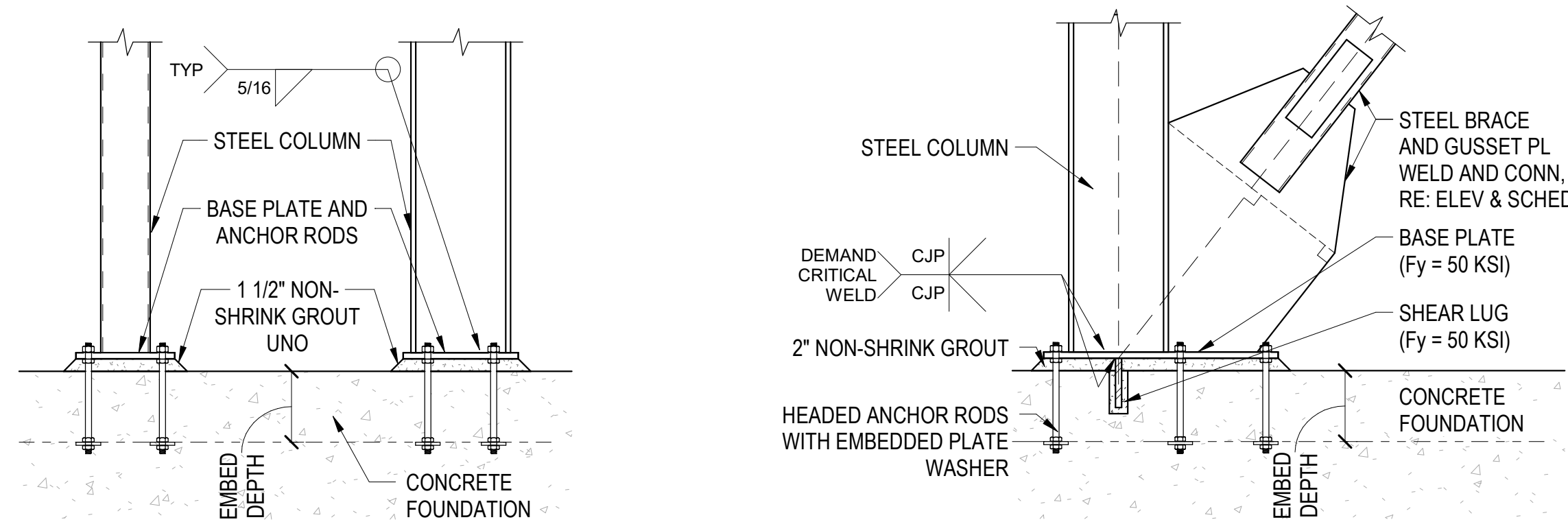

TYPICAL COLUMN BASE CONDITION

TYPICAL BRACED FRAME COLUMN BASE CONDITION

NOTES:

- ALL BASE PLATES AND SHEAR LUGS MUST BE ASTM A572 GR50 STEEL, TYP UNO
- ALL ANCHOR RODS MUST BE ASTM F-1554 GR55 MIN UNO. THEY MUST BE HEADED ANCHOR RODS W/ 3"x3"x3/8" PLATE WASHERS WITH DOUBLE NUTS OR EMBED PLATE EMBEDDED IN CONCRETE AT THE EMBEDMENT DEPTH SPECIFIED, TYP UNO.
 - ALL ANCHOR RODS MUST HAVE HARDENED WASHERS AND NUTS, WITH FULL HEIGHT OF EXTENSIONS THREADED
 - WASHERS MUST CONFORM TO AISC STEEL CONSTRUCTION MANUAL TABLE 14-2
 - BASE PLATE HOLES MAY INCREASE PER AISC STEEL CONSTRUCTION MANUAL TABLE 14-2
- ALL BASE PLATES MUST BEAR ON MIN 1 1/2" THICK (2" THICK AT BRACED FRAMES) 5000 PSI NON-SHRINK GROUT AND MUST HAVE LEVELING NUTS, TYP UNO
- ALL BASE PLATES MUST BE WELDED TO THE COLUMN WITH A 1/4" FILLET WELD ALL AROUND, TYP UNO
- ALL ANCHOR RODS MUST BE SET IN PLACE WITH A TEMPLATE. THEY MUST BE PLACED PLUMB AND AT THE CORRECT DEPTH AND EXTENSION
- THE WIDTH OF ALL SHEAR LUGS IS THE SAME AS THE "N" DIMENSION SHOWN IN BASE PLATE TYPES
- NOTCH SHEAR LUGS AS REQ'D TO ACCOMMODATE REINF STEEL
- SEE THE STRUCTURAL GENERAL NOTES FOR ADDITIONAL INFORMATION

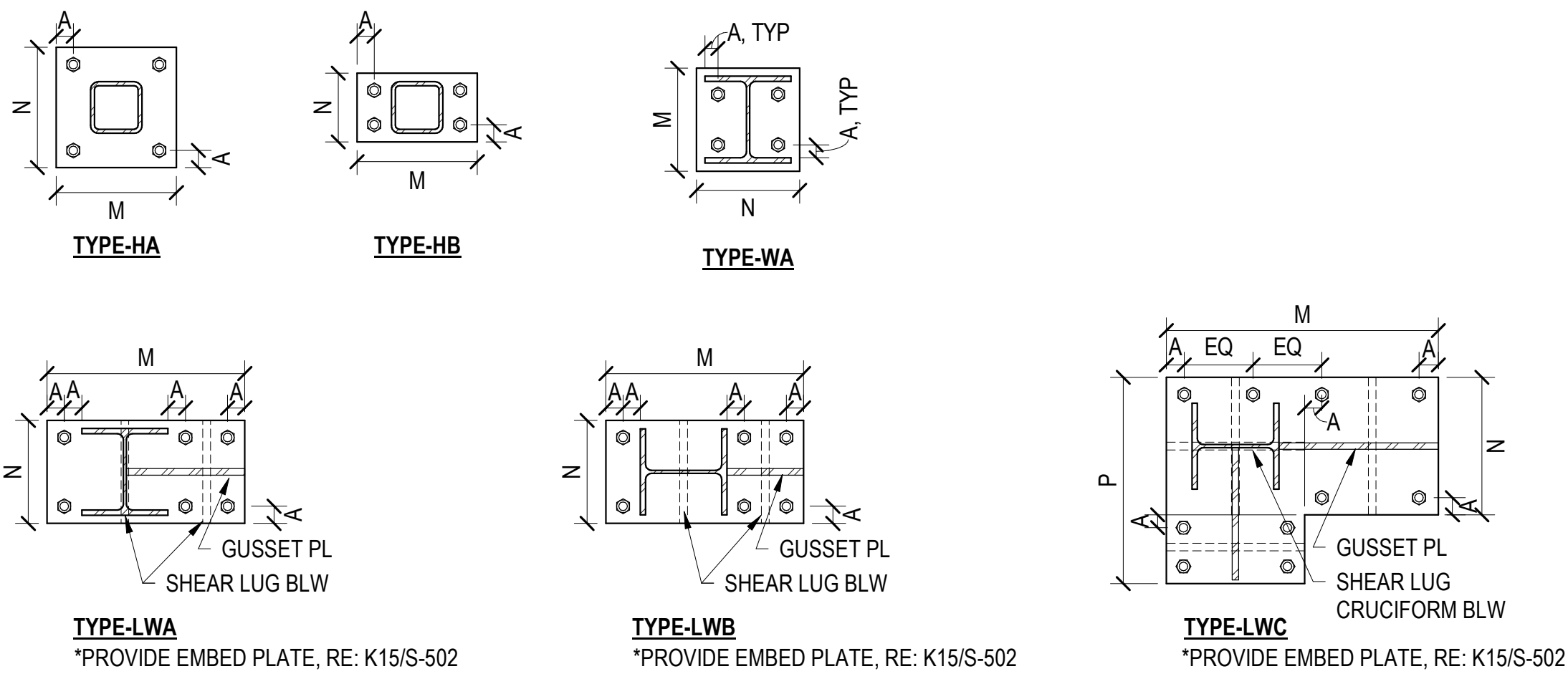

CONCRETE WALL SCHEDULE

MARK	WIDTH	TYPE	WALL REINFORCING		NOTES
			HORIZONTAL	VERTICAL	
CW8	8"	TYPE A	#5 @ 12" OC	#5 @ 12" OC	
CW15	1' - 3"	TYPE B	#5 @ 12" OC EF	#5 @ 12" OC EF	

NOTES:

- SEE TYPICAL DETAILS FOR REINFORCING AT CORNERS, INTERSECTIONS, AND OPENINGS.
- PROVIDE DOWELS WITH STANDARD HOOKS AND/OR PROPER LAP LENGTH TO THE STRUCTURE ABOVE AND BELOW WITH SIZE AND SPACING TO MATCH THE VERT REINF IN THE WALL, TYP UNO.
- THE LAP SPlice LENGTH OF VERT REINF MUST BE AS SHOWN IN THE CONCRETE REINF DEVELOPMENT AND LAP SPlice TABLE IN THE GENERAL NOTES. ADJUST HEIGHT OF EACH LIFT AS REQUIRED.
- WHEN A SINGLE CURTAIN OF REINF IS SPECIFIED, PLACE THE VERT REINF IN THE CENTER OF THE WALL, TYP UNO.
- AT TOP AND BTM OF WALL, INCLUDING ALL DECK BEARING ELEVATIONS, PROVIDE (2) #5 CONT IN ADDITION TO SCHEDULED REINFORCING.
- ALL HORIZONTAL REINF MUST TERMINATE AT ENDS OF WALLS AND ALL JAMBS WITH A STANDARD 180 DEGREE HOOK. END OF WALL IS DEFINED AS ANY WALL SEGMENT THAT EITHER CHANGES DIRECTION AND/OR CHANGES TO A DIFFERENT WALL TYPE.
- SEE GENERAL STRUCTURAL NOTES FOR ALL OTHER REQUIREMENTS.

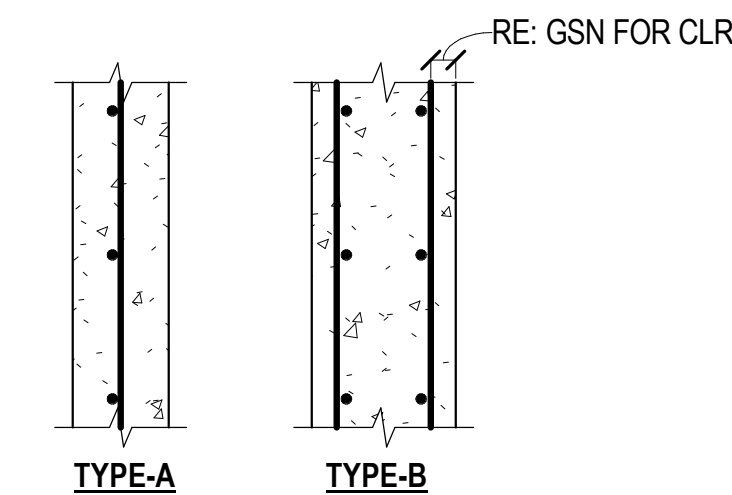

REINFORCED CONCRETE WALL TYPES

FOOTING SCHEDULE

MARK	WIDTH	LENGTH	THICK	TRANSVERSE REINFORCING		LONGITUDINAL REINFORCING		NOTES
				NO.	SIZE	NO.	SIZE	
FS3.0	3' - 0"	3' - 0"	1' - 0"	(4)	#5	(4)	#5	
FS4.0	4' - 0"	4' - 0"	1' - 0"	(5)	#5	(5)	#5	
FS6.0	6' - 0"	6' - 0"	1' - 4"	(7)	#6	(7)	#6	
FS7.0	7' - 0"	7' - 0"	1' - 6"	(8)	#6	(8)	#6	TOP & BOTTOM
FS8x12	8' - 0"	12' - 0"	2' - 0"	(13)	#7	(9)	#7	TOP & BOTTOM
FS10.0	10' - 0"	10' - 0"	2' - 0"	(11)	#7	(11)	#7	TOP & BOTTOM
FS10x35	10' - 0"	35' - 0"	2' - 6"	(36)	#8	(11)	#8	TOP & BOTTOM
FS10x37	10' - 0"	37' - 0"	2' - 6"	(38)	#8	(11)	#8	TOP & BOTTOM
FS11.0	11' - 0"	11' - 0"	2' - 0"	(12)	#7	(12)	#7	TOP & BOTTOM
FS18x30	18' - 0"	30' - 0"	2' - 6"	(31)	#8	(19)	#8	TOP & BOTTOM
FC3.0	3' - 0"	CONT	1' - 0"	(4)	#5	-	#5 @ 12" OC	
FC4.0	4' - 0"	CONT	1' - 0"	(5)	#6	-	#5 @ 12" OC	

NOTES:

- ALL FOOTINGS MUST BEAR ON PROPERLY PREPARED MATERIAL. SEE FOUNDATION SECTION OF THE STRUCTURAL GENERAL NOTES.
- ALL FOOTINGS MUST BE CENTERED BELOW THE WALL AND/OR COLUMN ABOVE, TYP UNO.
- ALL EARTH FORMED FOOTINGS MUST HAVE REQUIRED CONCRETE COVER FOR REINFORCEMENT PER THE CONCRETE COVER TABLE.
- ALL EXTERIOR FOOTINGS MUST BEAR BELOW THE EFFECTS OF FROST. SEE THE DESIGN CRITERIA SECTION OF THE STRUCTURAL GENERAL NOTES FOR MINIMUM BEARING DEPTH.
- PROVIDE MINIMUM COVER FOR ALL REINFORCING PER THE STRUCTURAL GENERAL NOTES AND/OR THE CONCRETE COVER SCHEDULE.
- PLACE ALL FOOTING REINFORCING IN BOTTOM OF FOOTING WITH 3" CLEAR CONCRETE COVER, TYP UNO.
- PLACE TRANSVERSE REINFORCING NEAREST EARTH AND LONGITUDINAL REINFORCING ON TOP OF TRANSVERSE REINFORCING.
- PLACE TOP REINFORCING IF NOTED ON SCHEDULE. AS A MINIMUM, ALL FOOTINGS GREATER THAN OR EQUAL TO 18" IN THICKNESS REQUIRE #6 @ 12" OC EA WAY IN THE TOP OF FOOTING UNLESS THE SCHEDULE PROVIDES MORE STRINGENT REQUIREMENTS.
- EXTEND CONTINUOUS FOOTINGS 12" MINIMUM PAST EDGE OF WALL, UNLESS OTHERWISE NOTED ON PLANS.
- REINFORCING IN CONTINUOUS FOOTINGS MUST PASS THROUGH INTERSECTING SPOT FOOTINGS.
- ALL REINFORCING FOR SPOT FOOTINGS AND MAT FOOTINGS AT BRACED FRAMES AND MOMENT FRAMES MUST HAVE A 90 DEGREE HOOK AT EA END.
- PROVIDE DOWELS WITH STANDARD HOOKS FROM FOOTINGS TO ANY REINFORCED ELEMENT ABOVE WITH SIZE AND SPACING TO MATCH VERTICAL REINFORCING IN THE ELEMENT ABOVE.
- ANY INCREASE IN THE SIZE OF FOOTINGS SHOWN MAY REQUIRE ADDITIONAL REINFORCING. COORDINATE WITH THE ENGINEER OF RECORD.
- PENETRATIONS THROUGH FOOTINGS ARE NOT ALLOWED WITHOUT PRIOR WRITTEN APPROVAL FROM THE ENGINEER OF RECORD.
- ALL CONTINUOUS FOOTINGS MUST BE FC2.0 MINIMUM, AND ALL SPOT FOOTINGS MUST BE FS3.0 MINIMUM UNO ON PLANS.
- SEE THE STRUCTURAL GENERAL NOTES FOR ADDITIONAL INFORMATION.

MASONRY WALL SCHEDULE

MARK	WIDTH	TYPE	WALL REINFORCING		NOTES
			HORIZONTAL	VERTICAL	
MW8	8"	A	#5 @ 48" OC	#5 @ 32" OC	

NOTES:

- SEE TYPICAL DETAILS FOR REINFORCING AT CORNERS, INTERSECTIONS, AND OPENINGS.
- GROUT ALL CELLS SOLID THAT CONTAIN REINFORCING, EMBEDS, AND/OR BOLTS, TYP.
- DO NOT SOLID GROUT WALLS UNO.
- ALL MASONRY BELOW GRADE MUST BE GROUTED SOLID.
- LAY ALL BLOCK IN RUNNING BOND, TYP UNO.
- HORIZONTAL WALL REINF MUST CONTINUE THROUGH LINTELS. WHERE BOTH HORIZ WALL AND LINTEL REINF OCCUR IN THE SAME COURSE, USE THE LARGER REINFORCEMENT ONLY.
- ALL HORIZ REINF MUST TERMINATE AT ENDS OF WALL AND JAMBS WITH STANDARD 180 DEG HOOKS. PLACE ADDITIONAL VERT BAR IN CENTER OF WALL IF NECESSARY.
- PROVIDE SCHEDULED BOUNDARY COLUMNS AT END OF WALLS. SEE TYP MASONRY ELEVATION.
- AT TOP AND BOTTOM OF WALL PROVIDE (2) #5 CONT IN ADDITION TO SCHEDULED REINFORCING.
- AT ALL DECK AND JOIST EMBED LOCATIONS, PROVIDE (2) #5 CONT IN ADDITION TO SCHEDULED REINFORCING.
- PROVIDE DOWELS WITH STANDARD HOOKS AND/OR PROPER LAP LENGTH TO THE STRUCTURE ABOVE AND BELOW WITH SIZE AND SPACING TO MATCH THE VERT REINF IN THE WALL, TYP UNO.
- THE LAP SPlice LENGTH OF VERT REINF MUST BE AS SHOWN IN THE MASONRY REINF LAP SPlice TABLE IN THE GENERAL NOTES. ADJUST HEIGHT OF EACH LIFT AS REQUIRED.
- WHEN A SINGLE CURTAIN OF REINF IS SPECIFIED, PLACE THE VERT REINF IN THE CENTER OF THE WALL, TYP UNO.
- WHEN A DOUBLE CURTAIN OF REINF IS SPECIFIED, PLACE EACH CURTAIN AT THE FACE OF THE WALL WITH THE VERT REINF CLOSEST TO THE SHELL WITH A CLEAR DISTANCE BETWEEN 1/2" AND 1" TO THE INSIDE FACE OF THE SHELL.
- ALL WALLS MUST INCLUDE LADDER TYPE JOINT REINF SPACED AT 16" OC VERTICALLY WITH AT LEAST TWO WIRES OF W1.7 (GALVANIZED).
- SEE GENERAL STRUCTURAL NOTES FOR ALL OTHER REQUIREMENTS.

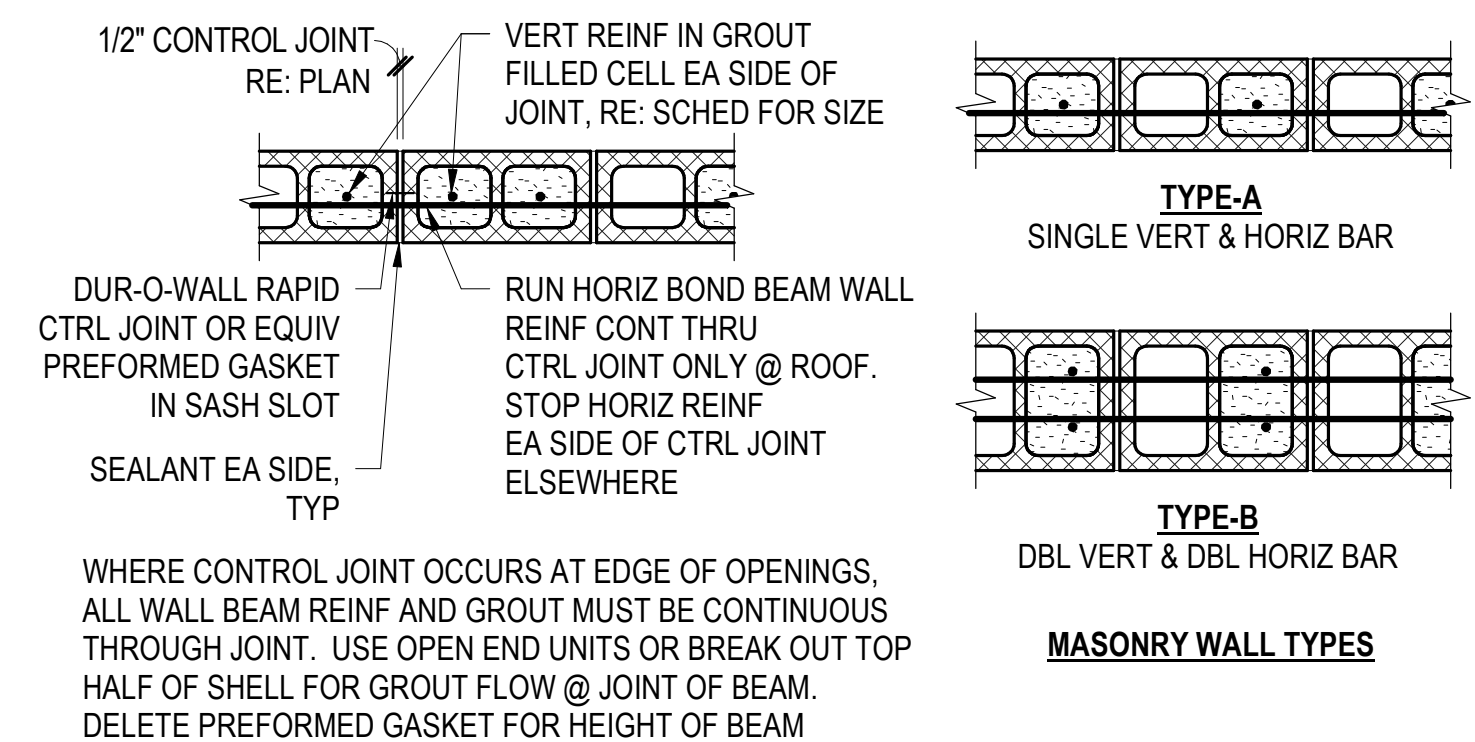

MASONRY WALL CONTROL JOINT

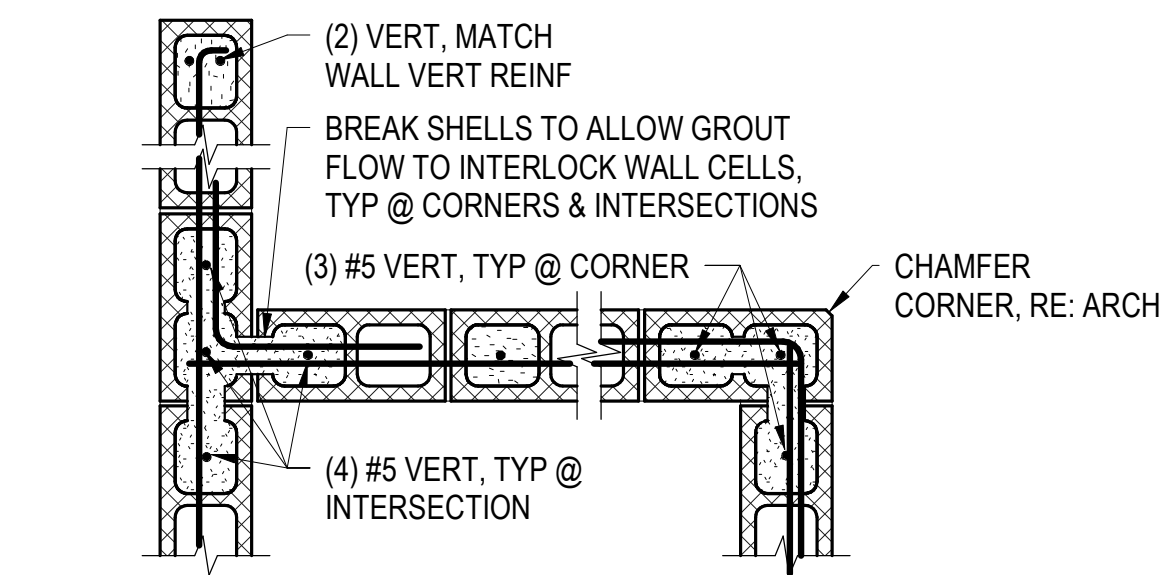

MASONRY WALL REINF LAYOUT



US Army Corps of Engineers

DATE	DESCRIPTION	MARK

ISSUE DATE: NOVEMBER 13, 2025	SOLICITATION NO.:	CONTRACT NO.:
A. VALENCIA	WB12PL25RA0012	WB12PL25C0037
DRAWN BY: R. CARLSON	CHECKED BY: D. CLAYSON	SUBMITTED BY: P. PASZCZUK
DESIGNED BY: A. VALENCIA	US ARMY CORPS OF ENGINEERS LOS ANGELES DISTRICT	KORTE CONSTRUCTION 5700 OAKLAND AVE, SUITE 275 ST. LOUIS, MO 63110

US ARMY CORPS OF ENGINEERS
LOS ANGELES DISTRICT

CREECH AIR FORCE BASE, CLARK COUNTY, NV
DISASTER RESILIENCY PROGRAM (DRP) - PHASE 2
494137
STRUCTURAL SCHEDULES

SHEET ID

S-601

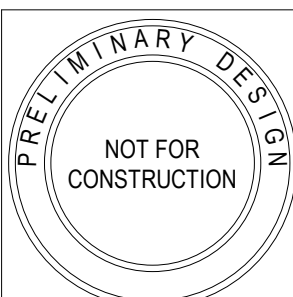

#	STEEL GUSSET PLATE CONNECTION SCHEDULE								NOTES
	MARK	GUSSET PLATE THICKNESS	GEOMETRY AND WELDING INFORMATION				COVER PLATE INFO		
		W1 SIZE	L1 LENGTH	W2 SIZE	L2 LENGTH	W3 SIZE	PLATE SIZE	WELD	
1	1"	5/16	3' - 3"	7/16	3' - 1"	7/16	1/2"x4"x1'-0"	1/4	
2	1"	5/16	3' - 3"	7/16	2' - 8"	7/16	1/2"x4"x1'-0"	1/4	
3	7/8"	5/16	1' - 7"	5/16	2' - 10"	3/8	1/2"x4"x1'-0"	1/4	
4	7/8"	5/16	1' - 7"	5/16	2' - 5"	3/8	1/2"x4"x1'-0"	1/4	
5	7/8"	5/16	1' - 7"	5/16	2' - 5"	3/8	1/2"x4"x1'-0"	1/4	
6	7/8"	5/16	1' - 7"	5/16	3' - 1"	3/8	1/2"x4"x1'-0"	1/4	
7	7/8"	5/16	1' - 7"	5/16	2' - 3"	3/8	1/2"x4"x1'-0"	1/4	
8	7/8"	5/16	1' - 7"	5/16	2' - 8"	3/8	1/2"x4"x1'-0"	1/4	
9	7/8"	5/16	3' - 3"	7/16	3' - 1"	3/8	1/2"x5"x1'-0"	1/4	
10	7/8"	5/16	3' - 3"	7/16	2' - 10"	7/16	1/2"x5"x1'-0"	1/4	
11	3/4"	5/16	1' - 0"	1/4	3' - 2"	1/4	1/2"x5"x1'-0"	1/4	
12	3/4"	5/16	1' - 0"	1/4	4' - 3"	1/4	1/2"x5"x1'-0"	1/4	
13	3/4"	5/16	1' - 0"	3/8	1' - 5"	3/8	1/2"x5"x1'-0"	1/4	
14	3/4"	5/16	1' - 0"	5/16	1' - 1"	3/8	1/2"x5"x1'-0"	1/4	
15	3/4"	5/16	1' - 0"	5/16	1' - 8"	5/16	1/2"x5"x1'-0"	1/4	
16	3/4"	5/16	1' - 0"	5/16	1' - 10"	5/16	1/2"x5"x1'-0"	1/4	

VENEER LINTEL SCHEDULE	
LOOSE LINTEL SCHEDULE FOR NON-LOAD BEARING MASONRY WALLS	
OPENING WIDTH	WALL THICKNESS
UP TO 4'-0"	4" WALL L4x3 1/2x5/16 LLV
4'-0" TO 6'-0"	L5x3 1/2x5/16 LLV
6'-0" TO 8'-0"	L6x3 1/2x5/16 LLV
8'-0" TO 12'-0"	L6x6x1/2
12'-0" TO 16'-0"	L8x6x5/8 LLV

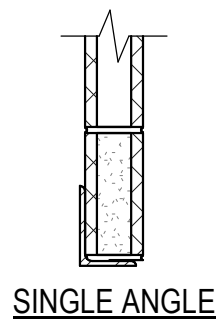

- NOTES:**
- RE: STRUCTURAL, ARCHITECTURAL, MECHANICAL, AND ELECTRICAL DRAWINGS FOR OPENING SIZE AND LOCATION.
 - CONNECT ALL DOUBLE ANGLES BACK TO BACK AT 2'-0" OC MAXIMUM SPACING.
 - PROVIDE 6" MINIMUM BEARING AT FIRST FULL MASONRY CELL AT EACH END OF LOOSE LINTEL.
 - FOR OPENINGS 6'-0" AND WIDER, FULLY GROUT FIRST FULL CELL EACH SIDE OF OPENING FOR FULL HEIGHT OF WALL.
 - FOR OPENINGS LESS THAN 6'-0" WIDE, FULLY GROUT FIRST FULL CELL EACH SIDE OF OPENING FOR MINIMUM HEIGHT OF 8", BUT NOT LESS THAN THE FULL CELL HEIGHT, BELOW LINTEL BEARING ELEVATION.
 - FULLY GROUT ALL CELLS WHERE LOOSE LINTELS ARE LOCATED.
 - ANGLES IN EXTERIOR WALLS ARE TO BE GALVANIZED.

MASONRY LINTEL SCHEDULE						
MARK	WIDTH	DEPTH	TYPE	LINTEL REINFORCING		NOTES
				HORIZONTAL	STIRRUPS	
MB16	7 5/8"	1' - 4"	A	(2) #5	N/A	
MB24	7 5/8"	2' - 0"	A	(2) #6 T+B	N/A	
MB32	7 5/8"	2' - 8"	A	(2) #5	N/A	

- NOTES:**
- LINTELS MUST BE OF THE SAME MATERIAL AND WIDTH AS THE WALL IN WHICH THEY ARE CONSTRUCTED.
 - LINTELS MUST BE GROUTED MONOLITHICALLY WITH THE SUPPORTING WALL AND COLUMNS.
 - GROUT LINTELS SOLID FOR DEPTH SHOWN IN THE SCHEDULE, PLUS AS PER DETAILS, STRUCTURAL NOTES, AND/OR WALL SCHEDULE.
 - EXTEND HORIZONTAL REINFORCING 48 BAR DIAMETERS MIN BEYOND THE EDGE OF ALL OPENINGS. PROVIDE A 90° STANDARD HOOK WHERE THIS CANNOT BE ACCOMPLISHED.
 - NO DUCTS, OPENINGS, OR PENETRATIONS WILL OCCUR THROUGH BEAMS UNO.
 - REINFORCING INDICATED IN LINTEL SCHEDULE IS IN ADDITION TO WALL HORIZ AND VERT REINFORCING.
 - SEE GENERAL STRUCTURAL NOTES FOR ALL OTHER REQUIREMENTS.

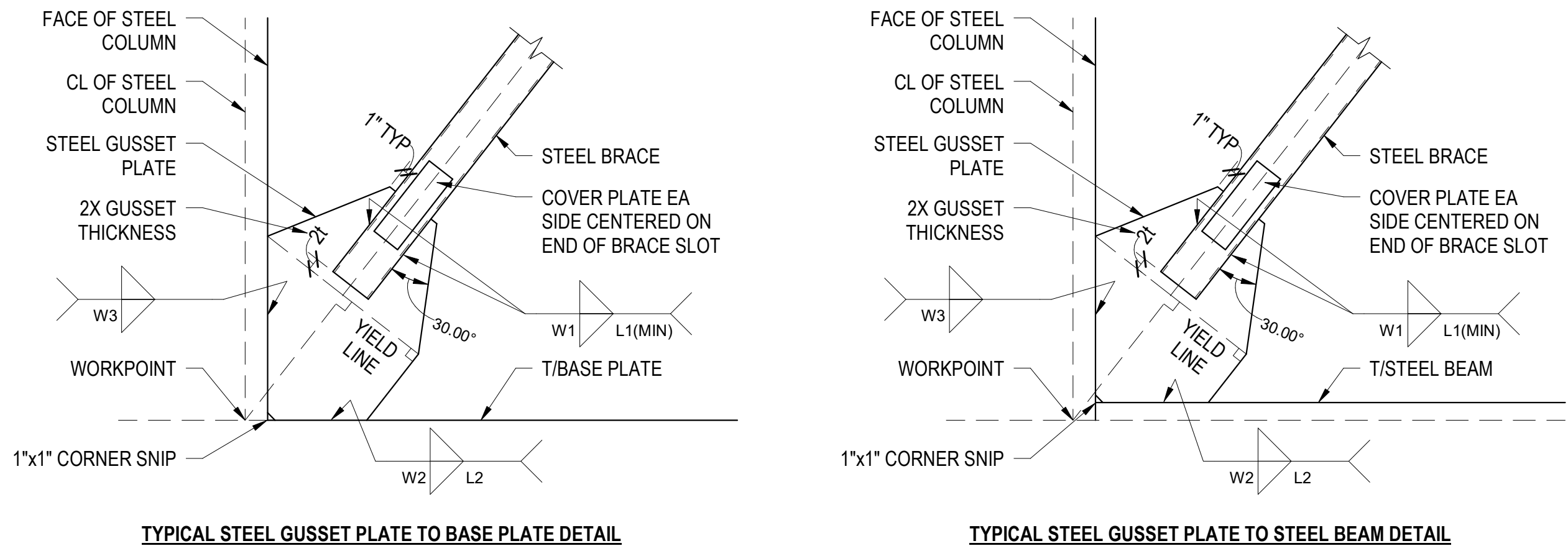
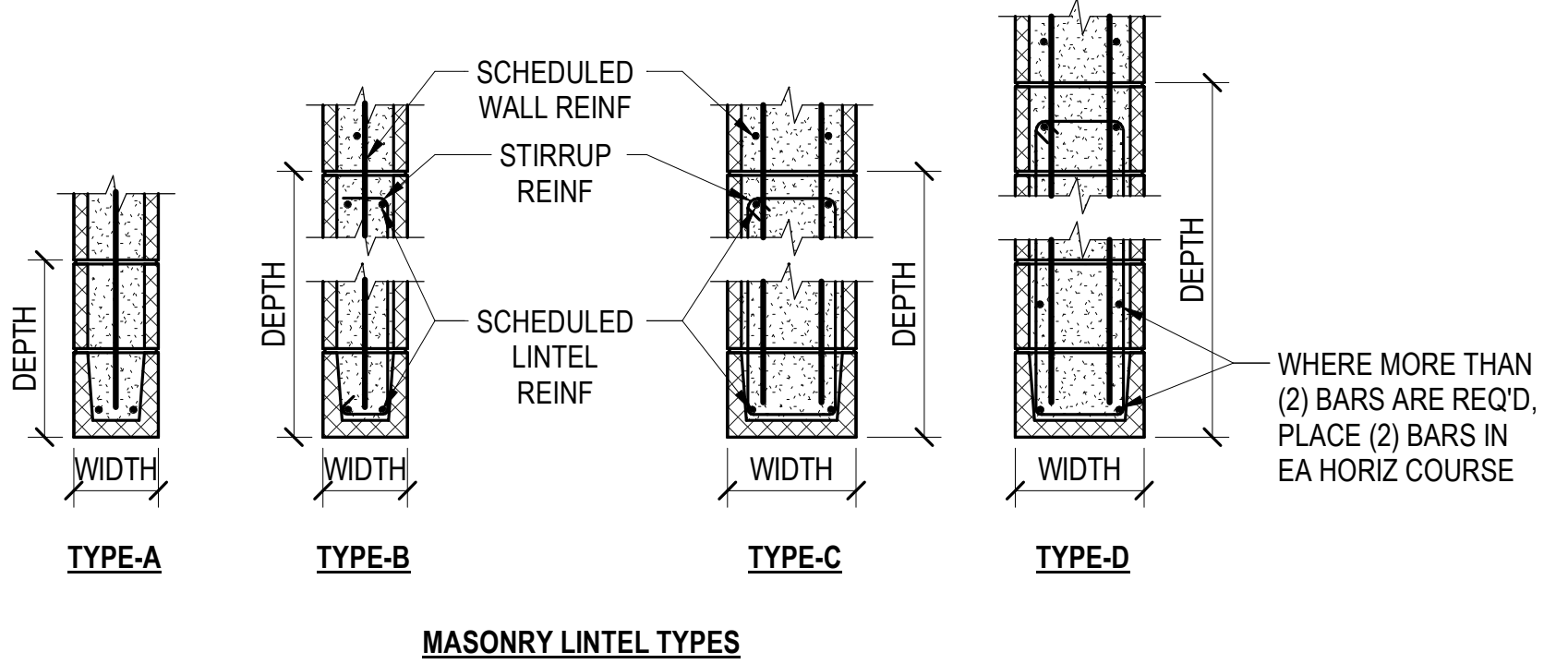

- NOTES:**
- RE: BRACED FRAME ELEVATIONS FOR MARKED LOCATIONS OF EACH GUSSET ASSEMBLY.
 - ALL GUSSET PLATES MUST BE A572 GRADE 50 STEEL.
 - ALL COVER PLATES MUST BE A572 GRADE 50 STEEL.
 - AT CONTRACTOR'S OPTION, FILLET WELDS MAY BE REPLACED WITH CJP WELDS SO LONG AS REQUIRED TESTING IS PERFORMED PER GOVERNING BUILDING CODE.
 - YIELD LINE SHOULD EXACTLY INTERSECT WITH COLUMN FACE OR BASE PLATE/BEAM FACE DEPENDING ON THE GEOMETRY.
 - LENGTH L1 IS A MINIMUM WELD LENGTH. USE LENGTH L2 AS A BASELINE TO ESTABLISH THE YIELD LINE.
 - PLACE 1/2" THICK FOAM EACH SIDE OF GUSSET PLATE WHEN CONCRETE POURS AROUND GUSSET PLATE.

MASONRY JAMB AND COLUMN SCHEDULE					
MARK	SIZE	TYPE	COLUMN REINFORCING		NOTES
			VERTICAL	TIES	
MP16	8x16	A2	#5 EA CELL	N/A	
MP32	8x32	A4	#6 EA CELL	N/A	

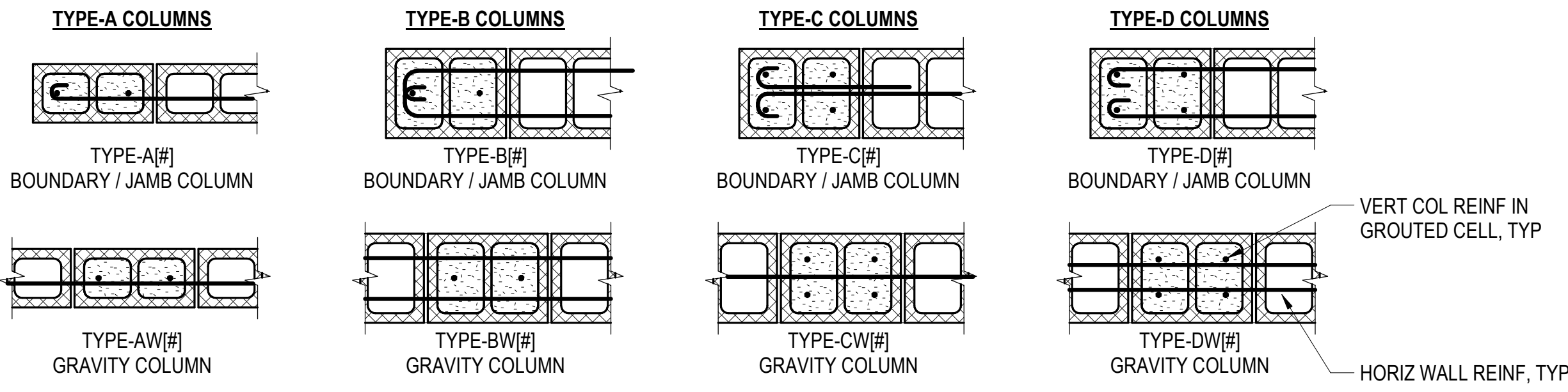

- NOTES:**
- DESIGNATION "TYPE A[#]" WHERE "A" EQUALS THE WALL TYPE IN WHICH THE COLUMN/JAMB OCCURS AND WHERE [#] EQUALS THE NUMBER OF VERTICALLY GROUTED CELLS CONTAINING REINFORCING.
 - HORIZONTAL WALL REINF MUST RUN CONTINUOUS THROUGH MASONRY COLUMNS.
 - GROUT ALL REINFORCED CELLS AND VOIDS SOLID.
 - MASONRY COLUMN REINF MUST EXTEND FULL HEIGHT FROM MARK ON PLAN DOWN TO FOUNDATION AND TERMINATE WITH A STANDARD 90° HOOK. FOR CONC FOUNDATION WALL HEIGHTS OVER 5'0", VERT MASONRY REINF MUST DOWEL 4'0" MIN INTO FOUNDATION WALL.
 - NUMBER OF VERT BARS IS TOTAL NUMBER OF BARS.
 - SEE ARCHITECTURAL DRAWINGS FOR SPECIAL COURSING ARRANGEMENTS.
 - ALL TIES MUST TERMINATE WITH A STANDARD MASONRY HOOK.
 - SEE MASONRY REINFORCING SPLICE LENGTH TABLES FOR REINF LAP LENGTHS.
 - SEE GENERAL STRUCTURAL NOTES FOR ALL OTHER REQUIREMENTS.



DATE	DESCRIPTION	MARK

ISSUE DATE: NOVEMBER 13, 2025	SOLICITATION NO.: W812P1253RA0012	CONTRACT NO.: W812P125C0037
DESIGNED BY: A. VALENCIA	DRAWN BY: R. CARLSON	CHECKED BY: D. CLAYSON

US ARMY CORPS OF ENGINEERS
LOS ANGELES DISTRICT

KORTE CONSTRUCTION
5700 OAKLAND AVE. SUITE 275
ST. LOUIS, MO 63110

CREECH AIR FORCE BASE, CLARK COUNTY, NV
DISASTER RESILIENCY PROGRAM (DRP) - PHASE 2
494137

STRUCTURAL SCHEDULES

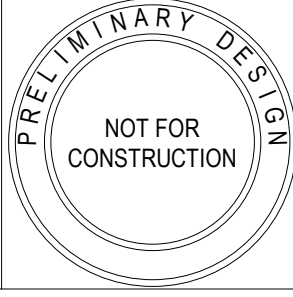

SHEET ID
S-602

STEEL COMPOSITE DECK SCHEDULE

MARK	STEEL DECK			CONCRETE FILL		TOTAL DECK THICKNESS	COMMENTS
	PROFILE	GAUGE	FINISH	WEIGHT	REINF		
SOD1	W2 W/ 4 1/2" NW CONC	20 GA	G60	145 PSF NW	#4 @ 18" OC EA WAY	6 1/2"	

NOTES:

1. STEEL FLOOR DECK MUST COMPLY WITH THE LATEST REQUIREMENTS OF THE STEEL DECK INSTITUTE (SDI).
2. WHEN FIRE PROOFING IS TO BE USED, DECK MUST BE COATED WITH SPECIAL PAINT IN ORDER TO PROPERLY RECEIVE FIRE PROOFING.
3. ALL DECK MUST BE INSTALLED WITH INTERLOCKING SIDE SEAMS, AND MUST BE CRIMPED PRIOR TO CONNECTING.
4. ALL DECK MUST BE 3-SPAN CONTINUOUS MINIMUM. CONTRACTOR MUST CONTACT ENGINEER AND PROVIDE OPTIONS WHEN 3-SPAN IS NOT POSSIBLE.
5. FLOOR DECK MUST BE WELDED TO SUPPORTING FRAME MEMBERS WITH 3/4" DIAMETER PUDDLE WELDS IN A (36/4) TYPE WELD PATTERN AND AT 12" OC AT ALL PERIMETERS AND 12" OC AT OTHER SUPPORTS PARALLEL TO CORRUGATIONS.
6. WHEN STUDS WELD THROUGH THE FLOOR DECK TO THE BEAMS BELOW, THEY MAY TAKE THE PLACE OF DESIGNATED PUDDLE WELDS.
7. ATTACH INTERLOCKING SEAMS WITH BUTTON PUNCH AT 18" OC OR 1 1/2" LONG TOP SEAM WELDS AT 24" OC. SIDE SEAMS MUST BE CRIMPED BEFORE WELDING.
8. MINIMUM DECK BEARING MUST BE 2".
9. ICC REPORT MUST BE SUBMITTED TO SHOW A MINIMUM ALLOWABLE DIAPHRAGM SHEAR VALUE OF XXXX LBS/FT FOR A 8'-0" DECK SPAN.
10. ALL DECK DESIGNATED AS G60 OR G90 IS GALVANIZED DECK.
11. CONCRETE SLAB ON STEEL FLOOR DECK MUST BE REINFORCED AS INDICATED IN THE SCHEDULE. REINFORCING IS TO BE PLACED 1 1/2" BELOW THE TOP OF THE SLAB.
12. GENERAL CONTRACTOR TO FOLLOW MANUFACTURER GUIDELINES FOR ALL DECK, CONNECTION, ATTACHMENTS, ETC.
13. FOR FINAL FINISH SEE ARCHITECT DRAWINGS AND SPECIFICATIONS.
14. RE: PLAN FOR NUMBER AND SIZE OF STUDS REQUIRED AT EACH BEAM. MAXIMUM STUD SPACING AT 12" OC.

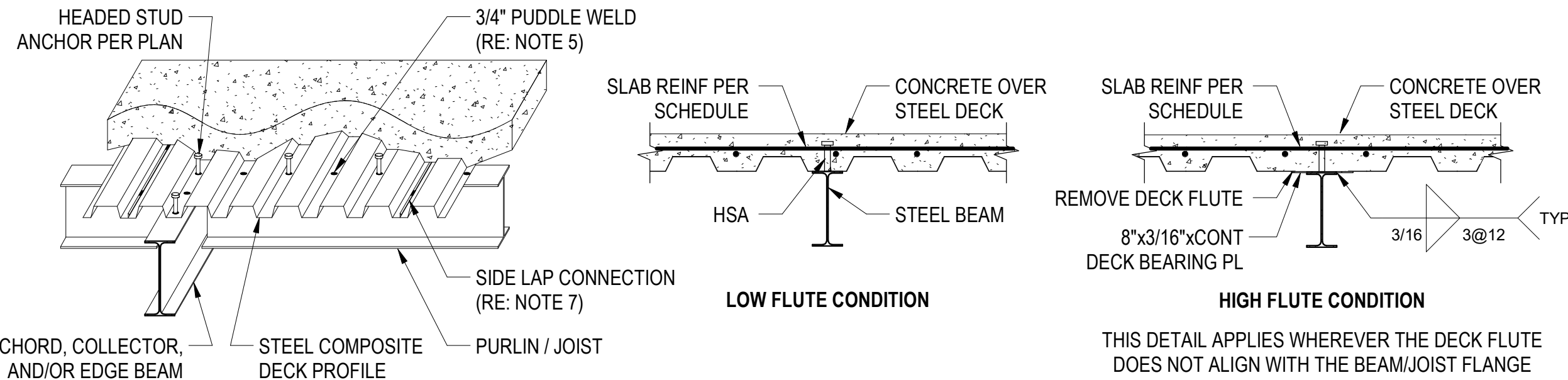

STEEL COMPOSITE DECK FASTENING PATTERN TO SUPPORT

TYPICAL COMPOSITE STEEL DECK CONNECTION

TYPICAL STEEL-TO-STEEL CONNECTION SCHEDULE

BEAM SIZE	NUMBER OF BOLTS
W8	(2) 3/4" DIA
W10	(2) 3/4" DIA
W12	(3) 3/4" DIA
W14	(3) 3/4" DIA
W16	(4) 3/4" DIA
W18	(5) 3/4" DIA
W21	(5) 3/4" DIA
W24	(6) 7/8" DIA
W27	(7) 7/8" DIA
W30	(8) 7/8" DIA
W33	(9) 7/8" DIA
W36	(10) 7/8" DIA
W40	(11) 7/8" DIA
W44	(12) 7/8" DIA

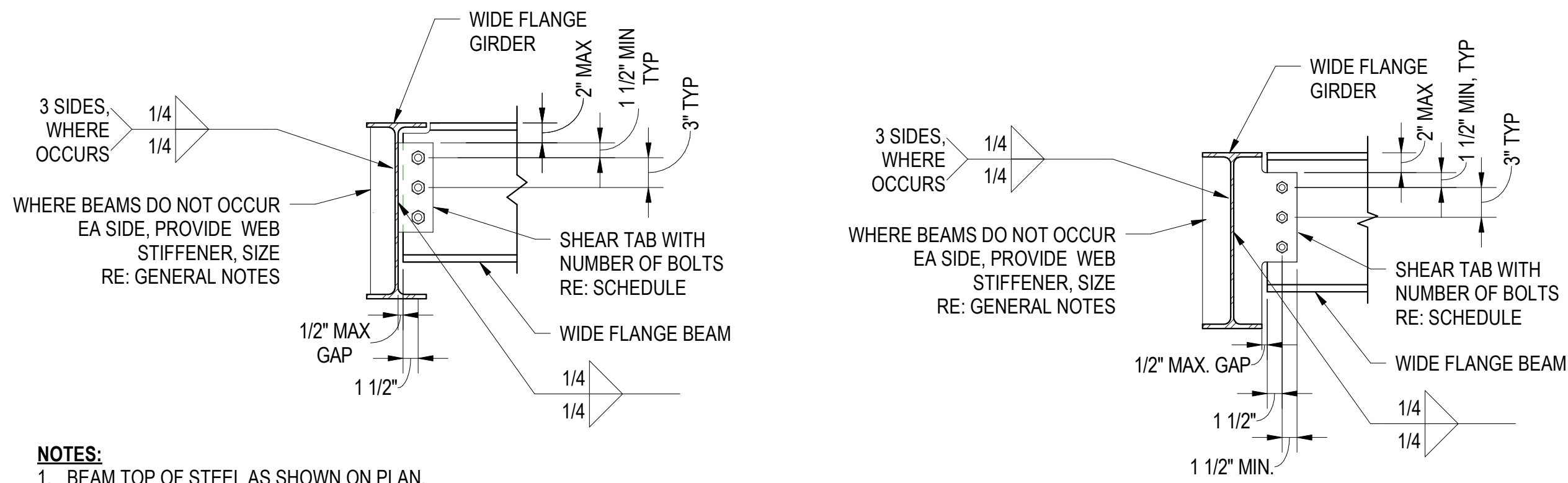

NOTES:

1. BEAM TOP OF STEEL AS SHOWN ON PLAN.
2. SEE PLANS FOR BEAM AND/OR COLUMN SIZES.
3. AT BRACED FRAMES, SEE BRACED FRAME ELEVATIONS/DETAILS FOR ALL STEEL SIZES AND CONNECTIONS.
4. ALL BOLTS SHALL BE A325-N UNLESS NOTED OTHERWISE.
5. ALL SHEAR TABS SHALL BE 3/8" UNLESS NOTED OTHERWISE.
6. DECK NOT SHOWN, SEE PLANS FOR FLOOR AND/OR ROOF STRUCTURE.
7. PROVIDE STANDARD OR HORIZONTAL SHORT SLOTTED HOLES IN SHEAR TAB.
8. FOR SHEAR TABS WELDED TO WIDE FLANGE OR HSS COLUMNS WITH 3/16" WALLS, USE 5/16" SHEAR PLATES.
9. FOR CONNECTIONS DESIGNATED AS DOUBLE-ANGLE CONNECTIONS, USE L5x3 ANGLES ON EACH SIDE OF THE BEAM INSTEAD OF A SHEAR PLATE. FOLLOW THE ANGLE SIZE AND SUPPORTING CONNECTION DETAILS SHOWN ON THE STEEL EMBED SCHEDULE. AT CONTRACTOR'S OPTION, DOUBLE-ANGLE CONNECTIONS CAN BE ALL BOLTED IN LIEU OF WELDING ANGLES TO SUPPORTING MEMBERS AS SHOWN ON THE EMBED SCHEDULE. IF ALL BOLTED, USE THE SAME NUMBER OF 3/4" BOLTS AND SPACING AS SHOWN ON THE SHEAR TABS OF THE STEEL CONNECTION SCHEDULE.

● BEAMS MARKED WITH SEISMIC DRAG STRUT CONNECTION ARE CONNECTED SIMILAR TO THOSE SHOWN ABOVE BUT THE SHEAR TAB OR ANGLE SHALL BE WELDED TO THE BEAM WEB WITH A 3-SIDED 1/4 FILLET WELD.

STEEL DECK SCHEDULE

MARK	STEEL DECK			DECK CONNECTION			SIDE LAP CONNECTION		DECK PERFORMANCE	
	PROFILE	GAUGE	FINISH	TYPE	PATTERN	EDGE SPACING	TYPE	SPACING	MIN SHEAR	MIN FLEXIBILITY
SD1	1 1/2" PLB-36	20	G60	HILTI X-HSN24 PAF	36/7	6" OC	VSC2	8" OC	--	--

NOTES:

1. STEEL ROOF DECK MUST COMPLY WITH THE LATEST REQUIREMENTS OF THE STEEL DECK INSTITUTE (SDI).
2. WHEN FIRE PROOFING IS TO BE USED, DECK MUST BE COATED WITH SPECIAL PAINT IN ORDER TO PROPERLY RECEIVE FIRE PROOFING.
3. ALL DECK MUST BE INSTALLED WITH INTERLOCKING SIDE SEAMS, AND MUST BE CRIMPED PRIOR TO CONNECTING.
4. MINIMUM SHEAR DENOTED IN SCHEDULE REPRESENTS THE MINIMUM ALLOWABLE DECK SHEAR FOR A 6'-0" SPAN REQUIRED FOR APPLICATION IN THIS PROJECT.
5. ALL DECK MUST BE 3-SPAN CONTINUOUS MINIMUM. CONTRACTOR MUST CONTACT ENGINEER AND PROVIDE OPTIONS WHEN 3-SPAN IS NOT POSSIBLE.
6. MINIMUM DECK BEARING MUST BE 2".
7. DO NOT SUPPORT ANY HANGING LOADS FROM STEEL ROOF DECK.
8. ALL DECK DESIGNATED AS G60 OR G90 IS GALVANIZED DECK.
9. GENERAL CONTRACTOR TO FOLLOW MANUFACTURER GUIDELINES FOR ALL DECK, CONNECTION, ATTACHMENTS, ETC.
10. FOR FINAL FINISH SEE ARCHITECT DRAWINGS AND SPECIFICATIONS.

LEGEND:

- ASW = 3/4" ARC SPOT WELD (PUDDLE WELD)
- BTN = BUTTON PUNCH (3/16")
- PIN = PIN CONNECTIONS (POWDER ACTUATED FASTENER)
- ACCEPTABLE FASTENERS:
HILTI X-HSN-24 @ SUPPORTS 3/16" THROUGH 3/8" THICK
HILTI X-ENP-19 @ SUPPORTS 1/4" THICK AND GREATER
- SCR = #10 SCREW
- TBD = DECK CONNECTION AND SIDELAP SPACING TO BE DETERMINED BY CONTRACTOR TO MEET THE MINIMUM ALLOWABLE SHEAR AND FLEXIBILITY REQUIREMENTS LISTED IN SCHEDULE. CONTRACTOR TO SUBMIT ICC REPORT.
- TSW = TOP SEAM WELD (1 1/2" IN LENGTH MINIMUM)
- VSC2 = VERCO PUNCHLOCK II SYSTEM
- VST = VERCO SHEARTRANZ II-42 SYSTEM

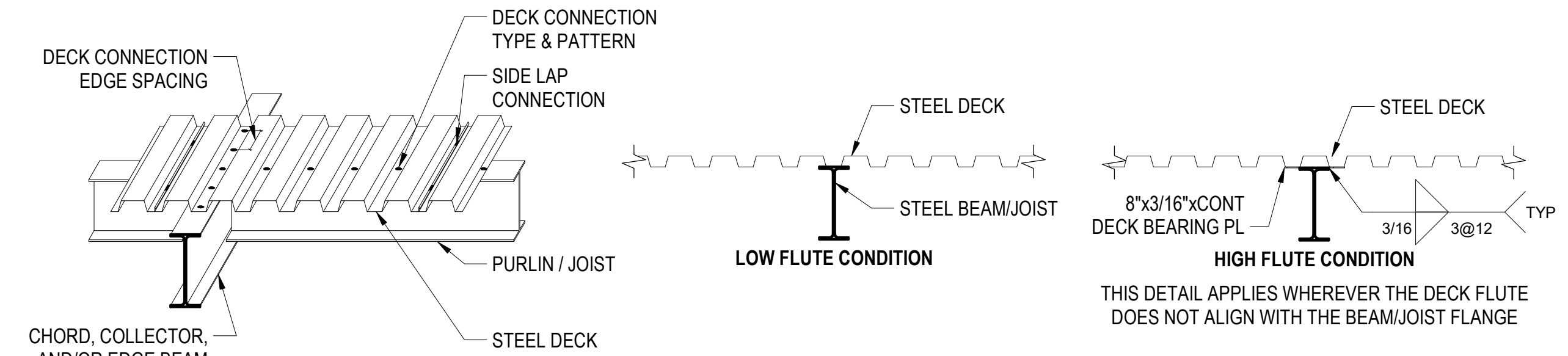

STEEL DECK FASTENING PATTERN TO SUPPORT

CHORD / COLLECTOR DECK CONNECTION

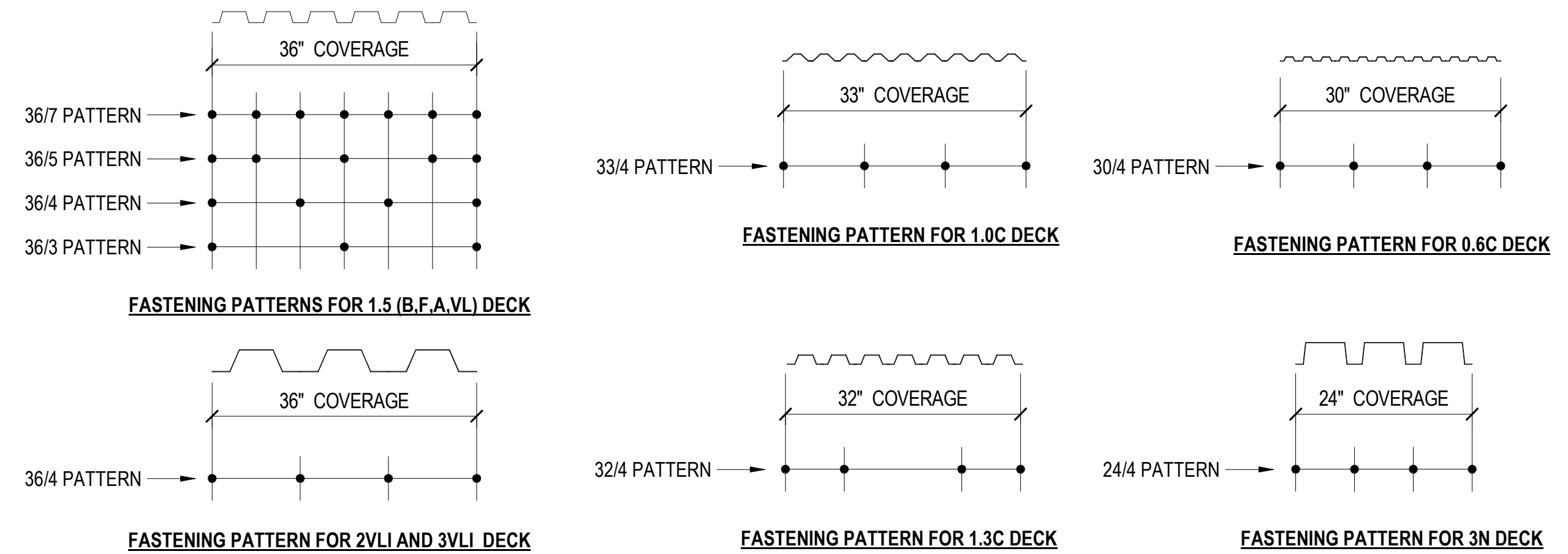

US Army Corps of Engineers®

DATE	DESCRIPTION	MARK

ISSUE DATE: NOVEMBER 13, 2025	DESIGNED BY: J. CORSON
SOLICITATION NO.: WB12PL25RA0012	DRAWN BY: R. CARLSON
CONTRACT NO.: WB12PL25C0037	CHECKED BY: D. CLAYSON
	SUBMITTED BY: P. PASZCZUK
	SIZE: ANSI D

US ARMY CORPS OF ENGINEERS
LOS ANGELES DISTRICT

KORTE CONSTRUCTION
5700 OAKLAND AVE. SUITE 275
ST. LOUIS, MO 63110

CREECH AIR FORCE BASE, CLARK COUNTY, NV
DISASTER RESILIENCY PROGRAM (DRP) - PHASE 2
494137

STRUCTURAL SCHEDULES

SHEET ID

S-603

1 2 3 4 5 6 7 8 9 10 11 12 13 14 15 16 17 18 19 20

P
N
M
L
K
J
H
G
F
E
D
C
B
A

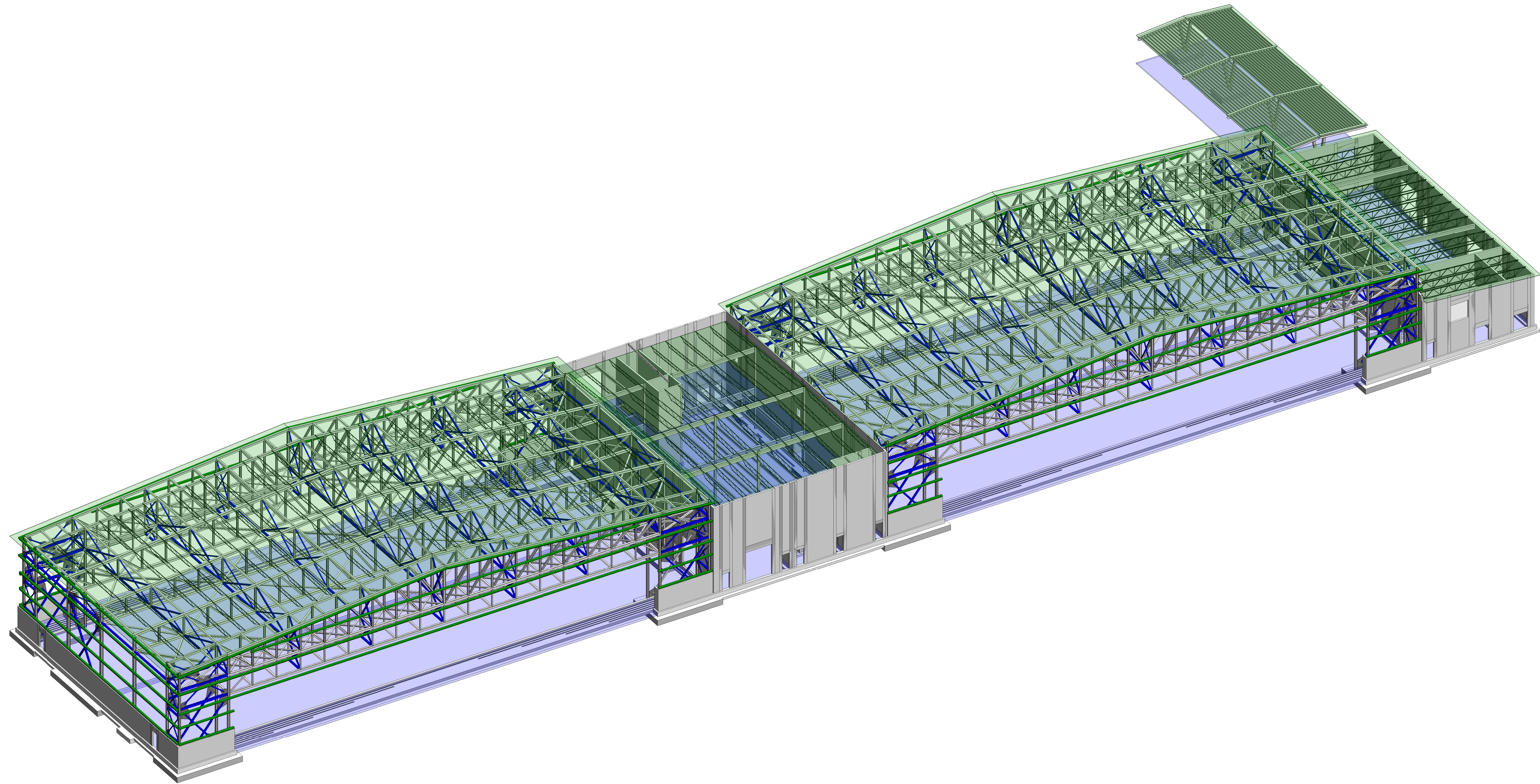

3D REFERENCE VIEW

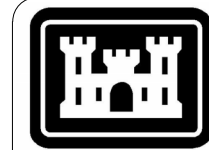

US Army Corps
of Engineers®

MARK	DESCRIPTION	DATE

DESIGNED BY: A. VALENCIA	ISSUE DATE: NOVEMBER 13, 2025
DRAWN BY: R. CARLSON	SOLICITATION NO.: W812PL25RA0012
CHECKED BY: D. CLAYSON	CONTRACT NO.: W812PL25C0037
SUBMITTED BY: P. PASZCZUK	SIZE: ANSI D
US ARMY CORPS OF ENGINEERS LOS ANGELES DISTRICT KORTE CONSTRUCTION 5700 OAKLAND AVE, SUITE 275 ST. LOUIS, MO 63110	

CREECH AIR FORCE BASE, CLARK COUNTY, NV DISASTER RESILIENCY PROGRAM (DRP) - PHASE 2 494137 3D REFERENCE VIEW

SHEET ID
S-901

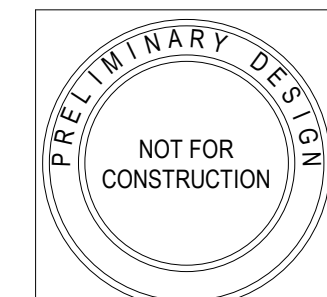

DP-1 95% SUBMISSION